



Chipsmall Limited consists of a professional team with an average of over 10 year of expertise in the distribution of electronic components. Based in Hongkong, we have already established firm and mutual-benefit business relationships with customers from,Europe,America and south Asia,supplying obsolete and hard-to-find components to meet their specific needs.

With the principle of "Quality Parts,Customers Priority,Honest Operation,and Considerate Service",our business mainly focus on the distribution of electronic components. Line cards we deal with include Microchip,ALPS,ROHM,Xilinx,Pulse,ON,Everlight and Freescale. Main products comprise IC,Modules,Potentiometer,IC Socket,Relay,Connector.Our parts cover such applications as commercial,industrial, and automotives areas.

We are looking forward to setting up business relationship with you and hope to provide you with the best service and solution. Let us make a better world for our industry!



Contact us

Tel: +86-755-8981 8866 Fax: +86-755-8427 6832

Email & Skype: info@chipsmall.com Web: www.chipsmall.com

Address: A1208, Overseas Decoration Building, #122 Zhenhua RD., Futian, Shenzhen, China



NHD-C0216CU-FSW-GBW-3V3

COG (Chip-on-Glass) Liquid Crystal Display Module

NHD- Newhaven Display
C0216- COG, 2 lines x 16 characters
CU- Model
F- Transflective
SW- Side White LED Backlight
G- STN-Gray
B- 6:00 View Angle
W- Wide Temp (-20° c ~ +70 c)
3V3- 3Vdd, 3.2V Backlight
RoHS Compliant

Newhaven Display International, Inc.

2511 Technology Drive, Suite 101

Elgin IL, 60124

Ph: 847-844-8795

Fax: 847-844-8796

www.newhavendisplay.com

nhtech@newhavendisplay.com

nhsales@newhavendisplay.com

Document Revision History

Revision	Date	Description	Changed by
0	8/29/2008	Initial Release	-
1	9/10/2009	User guide reformat	BE
2	10/9/2009	Updated Electrical Characteristics	MC
3	10/22/2009	Mechanical Drawing dimensions added	BE
4	11/19/2009	Updated backlight current	MC
5	8/5/2010	Electrical Characteristics Update	MP
6	5/17/2011	Updated Pin Description	BE

Functions and Features

- 2 lines x 16 characters
- Built-in ST7032-0D controller
- +3.0V power supply
- 8-bit parallel data input from MPU
- 1/16 duty, 1/5 bias
- No CGRAM available
- RoHS Compliant

Mechanical Drawing

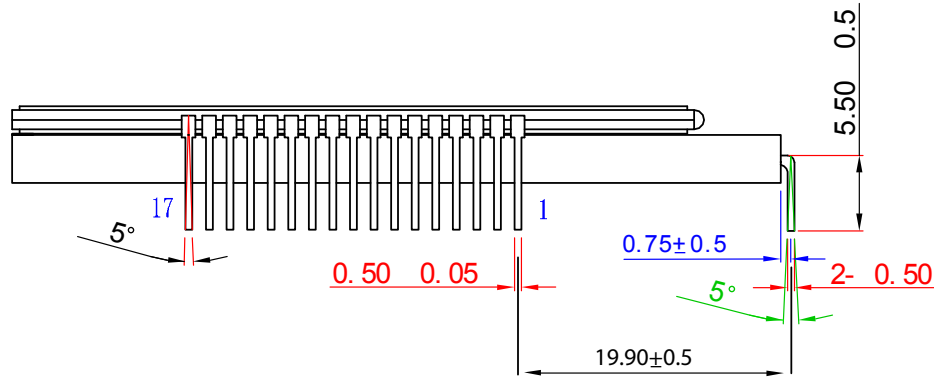
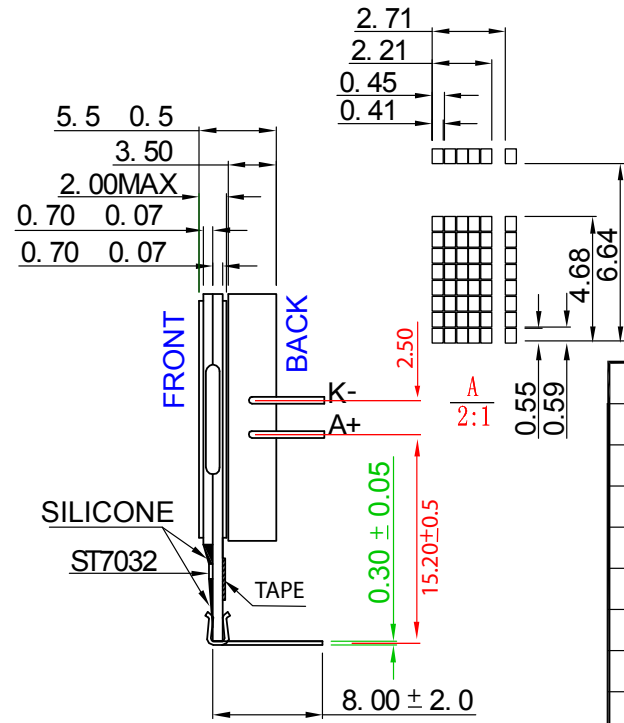
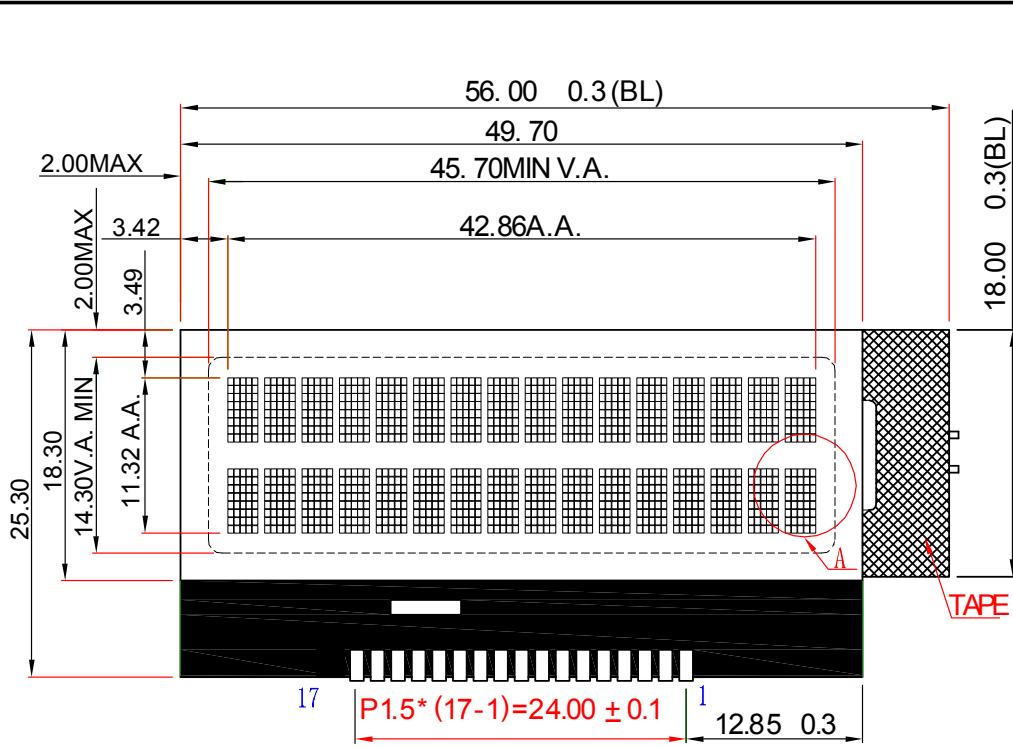

Note: The code which is printed on the back of B/L is "NHD-C0216CU-FSW-GBW-3V3"

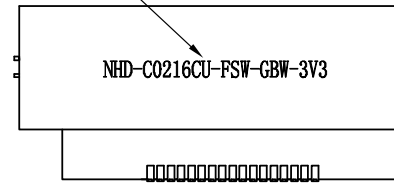

NO.	SYMBOL
17	CAP1N
16	CAP1P
15	VOUT
14	VDD
13	VSS
12	DB7
11	DB6
10	DB5
9	DB4
8	DB3
7	DB2
6	DB1
5	DB0
4	E
3	R/W
2	RS
1	XRESET

OPERATING VOLTAGE: 3.0V	OPERATING CURRENT: 1.0mA MAX(except B/L)
DISPLAY TYPE: STN(Gray) / Positive	POLARIZER MODE: Transflective
LCD DRIVE METHOD: 1/16 duty 1/5 bias 5.0V	VIEW DIRECTION: 6:00 O'CLOCK
LCD DRIVER IC: ST7032-0D(OPR1=1, OPR2=1)	BACKLIGHT: ILED, White, Side light, 3.2V, 20mA, 150cd/m
OPERATING TEMPERATURE: -20°C to +70°C	STORAGE TEMPERATURE: -30°C to +80°C
DEFAULT TOLERANCE: ±0.2	RoHS STANDARD: YES

TITLE		Customer Number	REV	D
		Product Model	NHD-C0216CU-FSW-GBW-3V3	UNIT
		Serial Number		DATE
APPROVED		SCALE	2:1	NO
				1/2

Newhaven Display

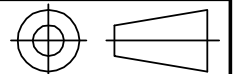

Pin Description and Wiring Diagram

Pin No.	Symbol	External Connection	Function Description
1	XRESET	MPU	Active LOW Reset Signal
2	RS	MPU	Register Select signal. RS=0: instruction; RS=1: data
3	R/W	MPU	Read/Write select signal, R/W=1: Read R/W: =0: Write
4	E	MPU	Operation enable signal. Falling edge triggered.
5-12	DB0-DB7	MPU	8-bit bi-directional data bus lines
13	Vss	Power Supply	Ground
14	VDD		Power supply for logic for LCD (+3.0V)
15	VOUT		DC/DC voltage converter. Connect to 1uF capacitor to VDD
16	CAP1P		Voltage booster circuit. Connect to 0.47uF-2.2uF cap to PIN17.
17	CAP1N		Voltage booster circuit. Connect to 0.47uF-2.2uF cap to PIN16.
A	LED+	Power Supply	Power supply for Backlight (3.2V)
K	LED-	Power Supply	Backlight Ground

Recommended LCD connector: 1.5mm pitch pins, solder to PCB

Backlight connector: --- Mates with: - - -

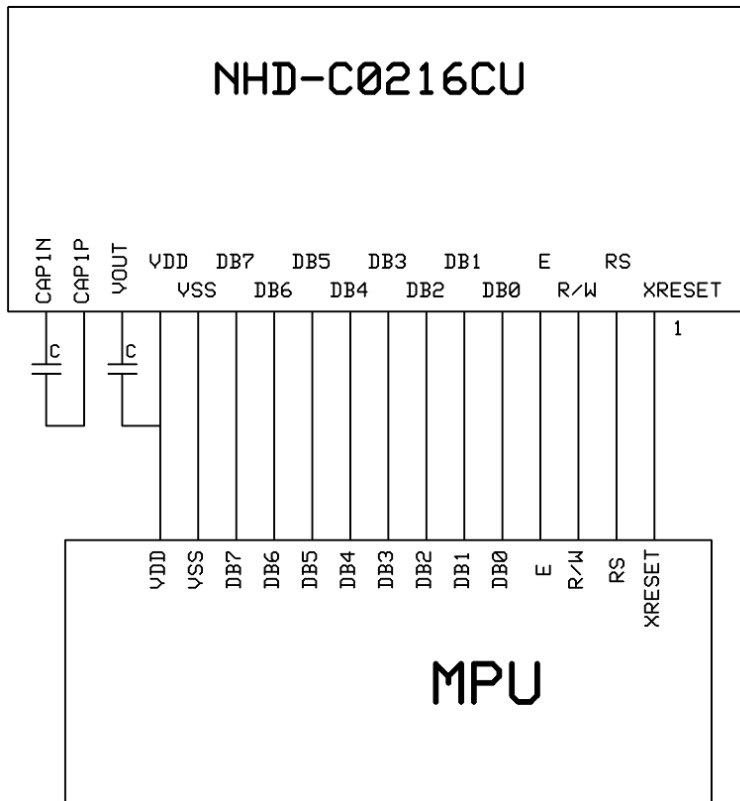

Electrical Characteristics

Item	Symbol	Condition	Min.	Typ.	Max.	Unit
Operating Temperature Range	Top	Absolute Max	-20	-	+70	°C
Storage Temperature Range	Tst	Absolute Max	-30	-	+80	°C
Supply Voltage	VDD		2.7	3.0	5.5	V
Supply Current	IDD	VDD=3.0V	-	-	1.0	mA
Supply for LCD (contrast)	VDD-Vo	Ta=25°C	4.8	5.0	5.2	V
"H" Level input	VIH		0.7VDD	-	VDD	V
"L" Level input	VIL	-	-	-	0.2VDD	V
Backlight supply voltage	VLED		2.8	3.2	3.4	V
Backlight supply current	ILED	VLED=3.2V	-	20	35	mA

Optical Characteristics

Item	Symbol	Condition	Min.	Typ.	Max.	Unit
Viewing Angle - Vertical	AV	Cr ≥ 3	-25	-	+45	°
Viewing Angle - Horizontal	AH	Cr ≥ 3	-35	-	+35	°
Contrast Ratio	K		3.0	-	-	-
Response Time (rise)	Tr	25°C	-	-	250	ms
Response Time (fall)	Tf	25°C	-	-	250	ms

Controller Information

Built-in ST7032. Download specification at http://www.newhavendisplay.com/app_notes/ST7032.pdf

Table of Commands

Instruction	Instruction Code										Description	Instruction Execution Time		
	RS	R/W	DB7	DB6	DB5	DB4	DB3	DB2	DB1	DB0		OSC=380KHz	OSC=540kHz	OSC=700KHz
Clear Display	0	0	0	0	0	0	0	0	0	1	Write "20H" to DDRAM. and set DDRAM address to "00H" from AC	1.08 ms	0.76 ms	0.59 ms
Return Home	0	0	0	0	0	0	0	0	1	x	Set DDRAM address to "00H" from AC and return cursor to its original position if shifted. The contents of DDRAM are not changed.	1.08 ms	0.76 ms	0.59 ms
Entry Mode Set	0	0	0	0	0	0	0	1	I/D	S	Sets cursor move direction and specifies display shift. These operations are performed during data write and read.	26.3 us	18.5 us	14.3 us
Display ON/OFF	0	0	0	0	0	0	1	D	C	B	D=1:entire display on C=1:cursor on B=1:cursor position on	26.3 us	18.5 us	14.3 us
Function Set	0	0	0	0	1	DL	N	DH	*0	IS	DL: interface data is 8/4 bits N: number of line is 2/1 DH: double height font IS: instruction table select	26.3 us	18.5 us	14.3 us
Set DDRAM address	0	0	1	AC6	AC5	AC4	AC3	AC2	AC1	AC0	Set DDRAM address in address counter	26.3 us	18.5 us	14.3 us
Read Busy flag and address	0	1	BF	AC6	AC5	AC4	AC3	AC2	AC1	AC0	Whether during internal operation or not can be known by reading BF. The contents of address counter can also be read.	0	0	0
Write data to RAM	1	0	D7	D6	D5	D4	D3	D2	D1	D0	Write data into internal RAM (DDRAM/CGRAM/ICONRAM)	26.3 us	18.5 us	14.3 us
Read data from RAM	1	1	D7	D6	D5	D4	D3	D2	D1	D0	Read data from internal RAM (DDRAM/CGRAM/ICONRAM)	26.3 us	18.5 us	14.3 us

Note * : this bit is for test command , and must always set to "0"

Instruction table 0 (IS=0)														
Cursor or Display Shift	0	0	0	0	0	1	S/C	R/L	x	x	S/C and R/L: Set cursor moving and display shift control bit, and the direction, without changing DDRAM data.	26.3 us	18.5 us	14.3 us
Set CGRAM	0	0	0	1	AC5	AC4	AC3	AC2	AC1	AC0	Set CGRAM address in address counter	26.3 us	18.5 us	14.3 us

Instruction table 1 (IS=1)														
Internal OSC frequency	0	0	0	0	0	1	BS	F2	F1	F0	BS=1:1/4 bias BS=0:1/5 bias F2~0: adjust internal OSC frequency for FR frequency.	26.3 us	18.5 us	14.3 us
Set ICON address	0	0	0	1	0	0	AC3	AC2	AC1	AC0	Set ICON address in address counter.	26.3 us	18.5 us	14.3 us
Power/ICON control/Contrast set	0	0	0	1	0	1	Ion	Bon	C5	C4	Ion: ICON display on/off Bon: set booster circuit on/off C5,C4: Contrast set for internal follower mode.	26.3 us	18.5 us	14.3 us
Follower control	0	0	0	1	1	0	Fon	Rab2	Rab1	Rab0	Fon: set follower circuit on/off Rab2~0: select follower amplified ratio.	26.3 us	18.5 us	14.3 us
Contrast set	0	0	0	1	1	1	C3	C2	C1	C0	Contrast set for internal follower mode.	26.3 us	18.5 us	14.3 us

Display Position										
	1	2	3	4	5	6		38	39	40
DDRAM Address (hexadecimal)	00	01	02	03	04	05	25	26	27
	40	41	42	43	44	45	65	66	67

Figure 10. 2-Line Display

Timing Characteristics

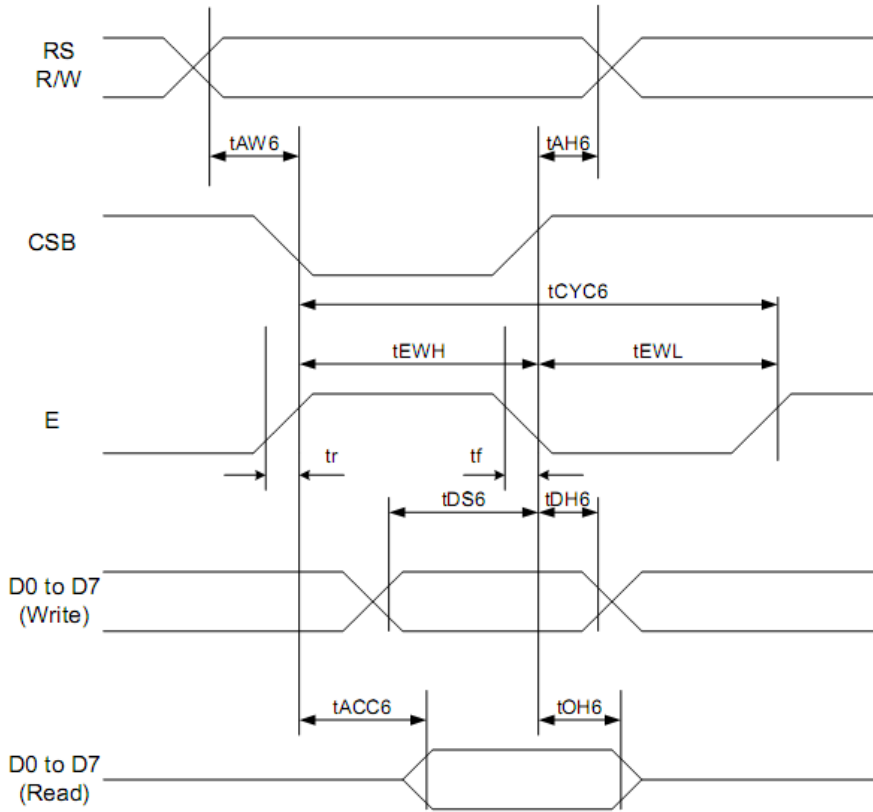

Item	Signal	Symbol	Condition	VDD=2.7 to 4.5V Rating		VDD=4.5 to 5.5V Rating		Units
				Min.	Max.	Min.	Max.	
Address hold time	RS	tAH6	—	20	-	20	-	ns
Address setup time	RS	tAW6		20	-	20	-	
System cycle time	RS	tCYC6	—	400	-	280	-	ns
Data setup time	D0 to D7	tDS6	—	100	-	80	-	ns
Data hold time	D0 to D7	tDH6		40	-	20	-	
Access time	D0 to D7	tACC6	CL = 100 pF	-	500	-	400	ns
Output disable time	D0 to D7	tOH6		300	-	150	-	
Enable Rise/Fall time	E	tr,tf	—	-	20	-	20	ns
Enable H pulse time	E	tEWH	—	200	-	120	-	ns
Enable L pulse time	E	tEWL	—	150	-	130	-	ns

Example Initialization Program

```

/*****
/*****
void init()                //initialize the LCD
{

P3 = 1;
P1 = 1;
RST = 0;                  //RESET
delay(2);
RST = 1;                  //end reset
delay(20);
Writecom(0x30);          //wake up
delay(2);
Call writecom(0x30);      //wake up
Call writecom(0x30);      //wake up
Call writecom(0x39);      //function set
Call writecom(0x14);      //internal osc frequency
Call writecom(0x56);      //power control
Call writecom(0x6D);      //follower control

Call writecom(0x70);      //contrast
Call writecom(0x0C);      //display on
Call writecom(0x06);      //entry mode
Call writecom(0x01);      //clear
delay(10);
}
/*****
void writecom(int c)
{
RW = 0;                  //Write
RS = 0;                  //Command
E = 1;
P1 = c;
E = 0;
}
/*****
void writedata(int d)
{
RW = 0;                  //Write
RS = 1;                  //Data
E = 1;
P1 = d;
E = 0;
}
/*****
/*****

```

Quality Information

Test Item	Content of Test	Test Condition	Note
High Temperature storage	Endurance test applying the high storage temperature for a long time.	+80°C , 96hrs	2
Low Temperature storage	Endurance test applying the low storage temperature for a long time.	-30°C , 96hrs	1,2
High Temperature Operation	Endurance test applying the electric stress (voltage & current) and the high thermal stress for a long time.	+70°C , 96hrs	2
Low Temperature Operation	Endurance test applying the electric stress (voltage & current) and the low thermal stress for a long time.	-20°C , 96hrs	1,2
High Temperature / Humidity Operation	Endurance test applying the electric stress (voltage & current) and the high thermal with high humidity stress for a long time.	+40°C , 90% RH , 96hrs	1,2
Thermal Shock resistance	Endurance test applying the electric stress (voltage & current) during a cycle of low and high thermal stress.	0°C,30min -> 25°C,5min -> 50°C,30min = 1 cycle 10 cycles	
Vibration test	Endurance test applying vibration to simulate transportation and use.	10-55Hz , 15mm amplitude. 60 sec in each of 3 directions X,Y,Z For 15 minutes	3
Static electricity test	Endurance test applying electric static discharge.	VS=800V, RS=1.5kΩ, CS=100pF One time	

Note 1: No condensation to be observed.

Note 2: Conducted after 4 hours of storage at 25°C, 0%RH.

Note 3: Test performed on product itself, not inside a container.

Precautions for using LCDs/LCMs

See Precautions at www.newhavendisplay.com/specs/precautions.pdf

Warranty Information and Terms & Conditions

http://www.newhavendisplay.com/index.php?main_page=terms