



Chipsmall Limited consists of a professional team with an average of over 10 year of expertise in the distribution of electronic components. Based in Hongkong, we have already established firm and mutual-benefit business relationships with customers from,Europe,America and south Asia,supplying obsolete and hard-to-find components to meet their specific needs.

With the principle of “Quality Parts,Customers Priority,Honest Operation,and Considerate Service”,our business mainly focus on the distribution of electronic components. Line cards we deal with include Microchip,ALPS,ROHM,Xilinx,Pulse,ON,Everlight and Freescale. Main products comprise IC,Modules,Potentiometer,IC Socket,Relay,Connector.Our parts cover such applications as commercial,industrial, and automotives areas.

We are looking forward to setting up business relationship with you and hope to provide you with the best service and solution. Let us make a better world for our industry!



## Contact us

Tel: +86-755-8981 8866 Fax: +86-755-8427 6832

Email & Skype: info@chipsmall.com Web: www.chipsmall.com

Address: A1208, Overseas Decoration Building, #122 Zhenhua RD., Futian, Shenzhen, China



# NHD-C0220AZ-FSW-FTW

## COG (Chip-on-Glass) Liquid Crystal Display Module

NHD- Newhaven Display  
C0220- COG, 2 lines x 20 characters  
AZ- Model  
F- Transflective  
SW- Side White LED backlight  
F- FSTN+  
T- 12:00 View Angle  
W- Wide Temp (-20 ~ +70C)  
**RoHS Compliant**

**Newhaven Display International, Inc.**

2511 Technology Drive, Suite 101

Elgin IL, 60124

Ph: 847-844-8795

Fax: 847-844-8796

[www.newhavendisplay.com](http://www.newhavendisplay.com)

[nhtech@newhavendisplay.com](mailto:nhtech@newhavendisplay.com)

[nhsales@newhavendisplay.com](mailto:nhsales@newhavendisplay.com)

## Document Revision History

Revision	Date	Description	Changed by
0	7/20/2008	Initial Release	
1	6/29/2009	User guide reformat	BE
2	10/9/2009	Updated Electrical Characteristics	MC
3	11/16/2009	Min Supply Voltage = 3.3V, Max VLCD = 5.0V	CL
4	11/19/2009	Updated backlight supply current	MC
5	5/14/2010	Controller Note	MP
6	3/14/2011	Update VLCD	CL
7	5/27/2011	Display character address code updated	AK
8	6/2/2011	Timing characteristics updated	AK
9	8/1/2011	Improve backlight, add orientation tabs	CL

## Functions and Features

- 2 lines x 20 characters
- Built-in NT7605 controller
- 5V power supply
- 1/16 duty, 1/5 bias

REV.	SYMBOL	DESCRIPTION	NAME	DATE
1	◆	Backlight orientation tabs		8-1-2011

VIEWING DIRECTION

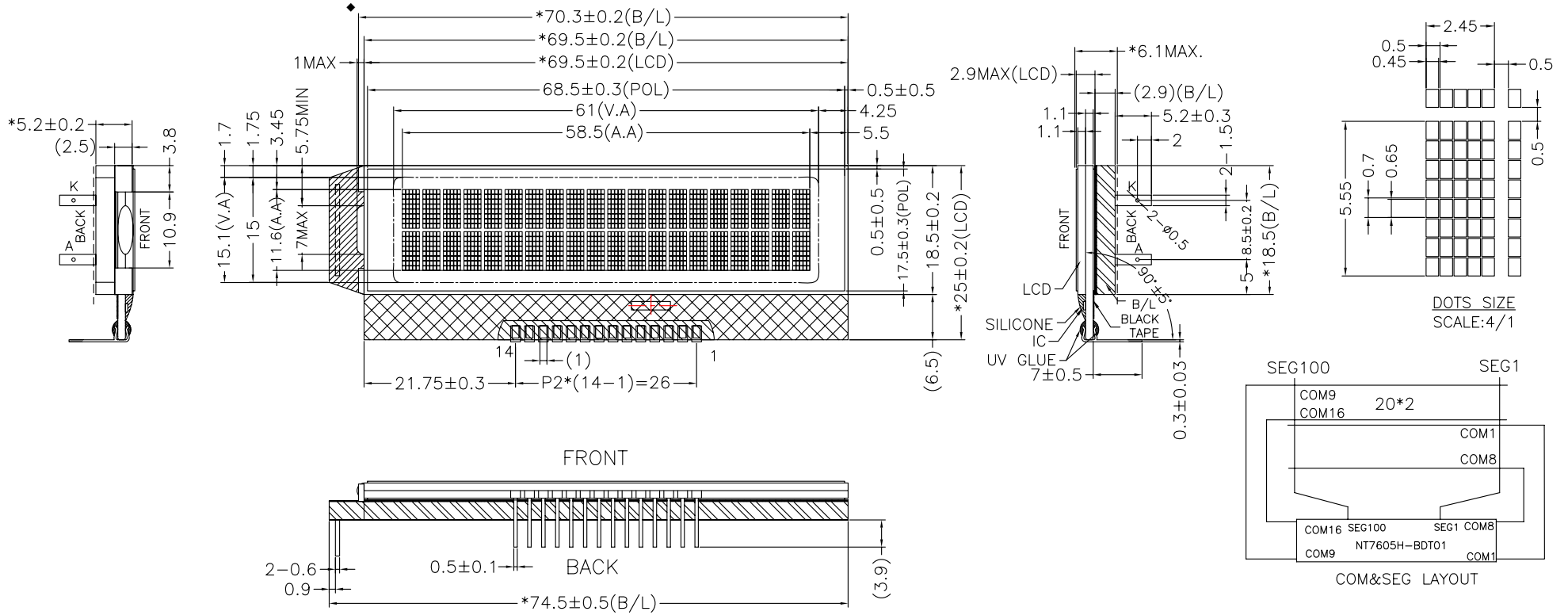

PIN	1	2	3	4	5	6	7
CONNECTION	GND	V5	VDD	RS	R/W	E	DB0
PIN	8	9	10	11	12	13	14
CONNECTION	DB1	DB2	DB3	DB4	DB5	DB6	DB7

ITEM	PARAMETERS	ITEM	PARAMETERS
DISPLAY TYPE	FSTN, POSITIVE	VIEWING DIRECTION	12 O'CLOCK
DRIVING METHOD	1/16 DUTY, 1/5 BIAS	OPERATING TEMPERATURE	-20°C TO +70°C
POLARIZER TYPE	TRANSFLECTIVE	STORAGE TEMPERATURE	-30°C TO +80°C
LCD OPERATING VOLTAGE	4.4V	IC	NT7605H-BDT01(OR COMPATIBLE)
LOGIC VOLTAGE(VDD)	5.0V	BACKLIGHT	EDGE WHITE(2PCS,VF=3.1±0.2V,IF=30mA)
RoHS COMPLIANT		CONNECTOR	COG
DIMENSIONS WITH MARK "*" ARE IMPORTANT, WITH MARK "(" ) ARE REFERENCED, WITH MARK "☆" ARE SPECIAL CHARACTERISTICS, WITH MARK "●" ARE IMPROTANT CHARACTERISTICS.			

UNMARKED TOLERANCE ±0.3			
SCALE	FIT	UNIT	mm
SHEET 1 OF 1	REV.	0	



TITLE	LCM	NAME	DATE
PART NO.	NHD-C0220AZ-FSW-FTW	DRAWN	
MODULE NO.		CHECKED	
CUSTOMER NO.		APPROVED	

## Pin Description and Wiring Diagram

Pin No.	Symbol	External Connection	Function Description
1	GND	Power Supply	Ground
2	V5	Adj Power Supply	Contrast voltage adjustment (~0.6V )
3	VDD	Power Supply	Power supply for LCD and logic
4	RS	MPU	Register Select: 0=Instruction, 1=Data
5	R/W	MPU	Read / Write select: 0=Write, 1=Read
6	E	MPU	Read/Write start signal (Schmitt trigger input)
7-10	DB0 – DB3	MPU	Low 4 tri-state bi-directional data bus lines. Not used in 4-bit mode.
11-14	DB4 – DB7	MPU	High 4 tri-state bi-directional data bus lines.

**Recommended LCD connector:** 2.0mm pitch, 14pins Soldered to PCB, or JST p/n: PHR-14

**Backlight connector:** A and K pins **Mates with:** Solder to wires or PCB

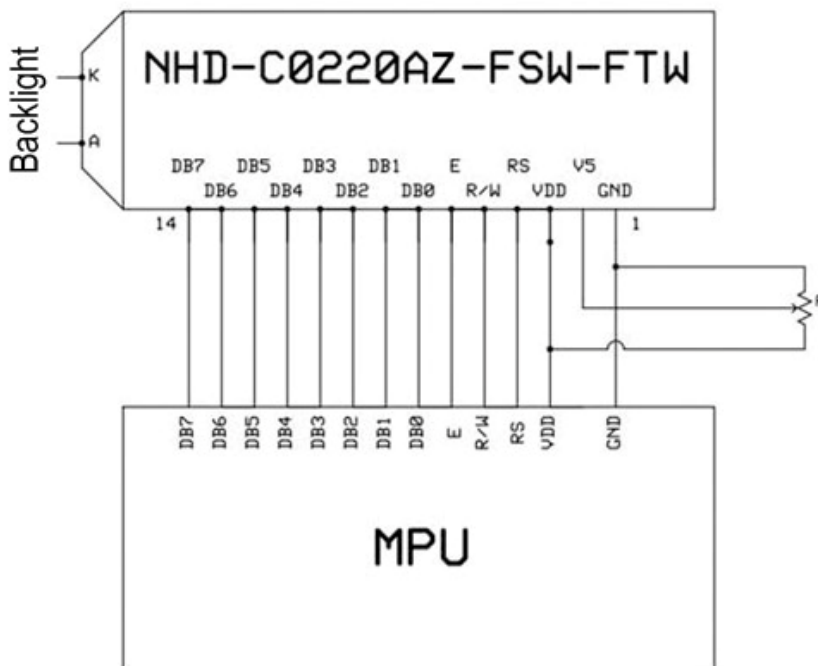

## Electrical Characteristics

Item	Symbol	Condition	Min.	Typ.	Max.	Unit
Operating Temperature Range	Top	Absolute Max	-20	-	+70	°C
Storage Temperature Range	Tst	Absolute Max	-30	-	+80	°C
Supply Voltage	VDD	Ta =25°	3.3	5.0	5.5	V
Supply Current	IDD	VDD=5.0V	-	1.0	1.5	mA
Supply for LCD (contrast)	VDD-V5	Ta =0°	-	4.5	-	V
		Ta =25°	-	4.4	-	
		Ta =60°	-	4.3	-	
"H" Level input	Vih		2.2	-	VDD	V
"L" Level input	Vil		0	-	0.6	V
"H" Level output	Voh		2.4	-	-	V
"L" Level output	Vol		-	-	0.4	V
Backlight Supply Voltage	VLED		-	3.0	-	V
Backlight Supply Current	Iled	VLED=3.0V	-	30	45	mA

## Optical Characteristics

Item	Symbol	Condition	Min.	Typ.	Max.	Unit
Viewing Angle - Vertical	AV	Cr ≥ 2	-60	-	+35	°
Viewing Angle - Horizontal	AH	Cr ≥ 2	-40	-	+40	°
Contrast Ratio	Cr		-	6	-	
Response Time (rise)	Tr	-	-	150	250	ms
Response Time (fall)	Tr	-	-	150	250	ms

## Controller Information

Built-in NT7605N-BDT01. Download specification at [http://www.newhavendisplay.com/app\\_notes/NT7605.pdf](http://www.newhavendisplay.com/app_notes/NT7605.pdf)

**NOTE:** The Busy Flag of the NT7605 controller may not always be responsive. Add sufficient delays and/or a time-out check routine to continue operation if busy flag is not cleared.

Note: during internal operation, busy flag (DB7) is read "High".  
 Busy flag check must be preceded by the next instruction.

## Table of Commands

Instruction	Instruction code										Description	Execution time (fosc= 270 KHZ)
	RS	R/W	DB7	DB6	DB5	DB4	DB3	DB2	DB1	DB0		
Clear Display	0	0	0	0	0	0	0	0	0	1	Write "20H" to DDRA and set DDRAM address to "00H" from AC	1.53ms
Return Home	0	0	0	0	0	0	0	0	1	-	Set DDRAM address to "00H" From AC and return cursor to its original position if shifted. The contents of DDRAM are not changed.	1.53ms
Entry mode Set	0	0	0	0	0	0	0	1	I/D	SH	Assign cursor moving direction And blinking of entire display	39us
Display ON/OFF control	0	0	0	0	0	0	1	D	C	B	Set display (D), cursor (C), and Blinking of cursor (B) on/off Control bit.	
Cursor or Display shift	0	0	0	0	0	1	S/C	R/L	-	-	Set cursor moving and display Shift control bit, and the Direction, without changing of DDRAM data.	39us
Function set	0	0	0	0	1	DL	N	F	-	-	Set interface data length (DL: 8-Bit/4-bit), numbers of display Line (N: =2-line/1-line) and, Display font type (F: 5x11/5x8)	39us
Set CGRAM Address	0	0	0	1	AC5	AC4	AC3	AC2	AC1	AC0	Set CGRAM address in address Counter.	39us
Set DDRAM Address	0	0	1	AC6	AC5	AC4	AC3	AC2	AC1	AC0	Set DDRAM address in address Counter.	39us
Read busy Flag and Address	0	1	BF	AC6	AC5	AC4	AC3	AC2	AC1	AC0	Whether during internal Operation or not can be known By reading BF. The contents of Address counter can also be read.	0us
Write data to Address	1	0	D7	D6	D5	D4	D3	D2	D1	D0	Write data into internal RAM (DDRAM/CGRAM).	43us
Read data From RAM	1	1	D7	D6	D5	D4	D3	D2	D1	D0	Read data from internal RAM (DDRAM/CGRAM).	43us

## Display Character Address Code

1	2	3	4	5	6	7	8	9	10	11	12	13	14	15	16	17	18	19	20
00	01	02	03	04	05	06	07	08	09	0A	0B	0C	0D	0E	0F	10	11	12	13
40	41	42	43	44	45	46	47	48	49	4A	4B	4C	4D	4E	4F	50	51	52	53

# Timing Characteristics

## Read Operation

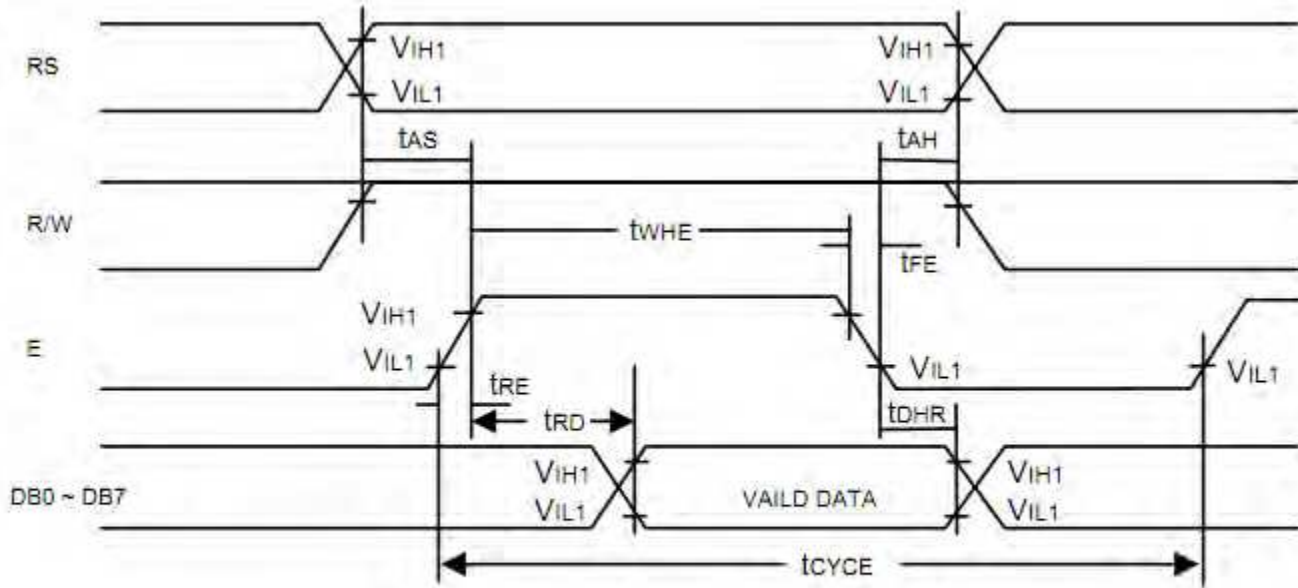

Figure 1. Bus Read Operation Sequence  
(Reading out data from NT7605 to MPU)

Read Cycle ( $V_{DD} = 5.0V$ ,  $GND = 0V$ ,  $T_A = 25^\circ C$ )

Symbol	Parameter	Min.	Typ.	Max.	Unit	Conditions
$t_{CYCE}$	Enable Cycle Time	500	-	-	ns	Figure 1
$t_{WHE}$	Enable "H" Level Pulse Width	300	-	-	ns	Figure 1
$t_{RE}, t_{FE}$	Enable Rise/Fall Time	-	-	25	ns	Figure 1
$t_{AS}$	RS, R/W Setup Time	$60^1$	-	-	ns	Figure 1
		$100^2$				
$t_{AH}$	RS, R/W Address Hold Time	10	-	-	ns	Figure 1
$t_{RD}$	Read Data Output Delay	-	-	190	ns	Figure 1
$t_{DHR}$	Read Data Hold Time	20	-	-	ns	Figure 1

Notes: 1: 8-bit operation mode  
2: 4-bit operation mode



## Write Operation

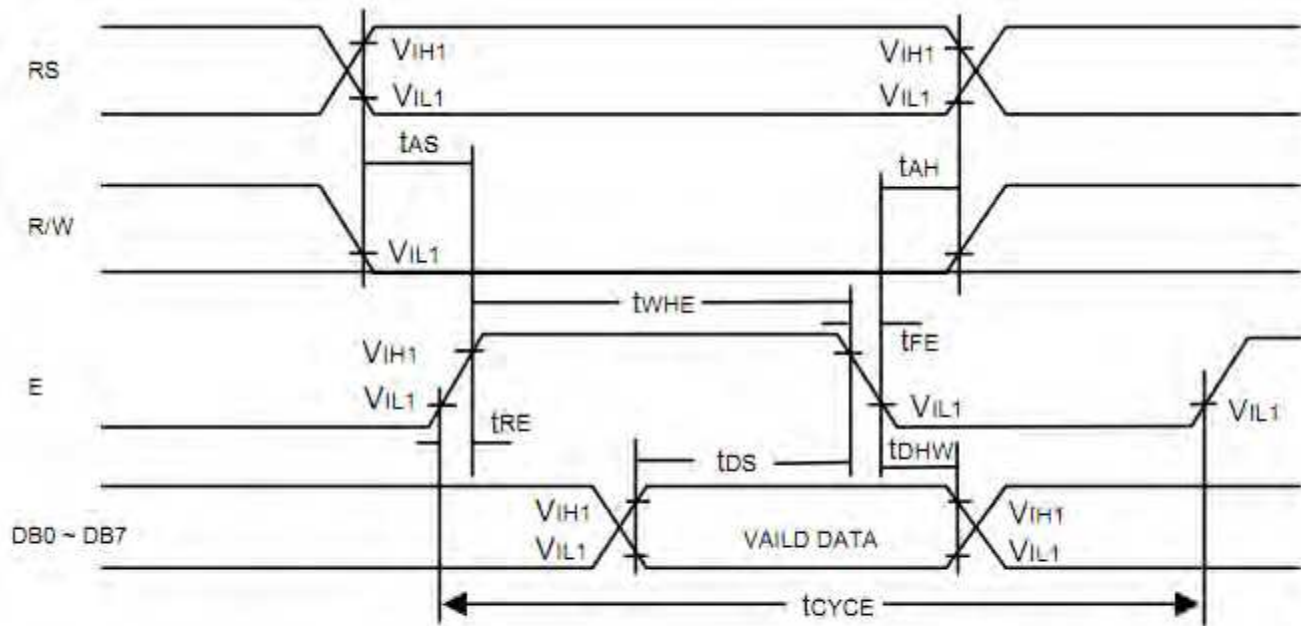

Figure 2. Bus Write Operation Sequence  
(Writing data from MPU to NT7605)

Write Cycle ( $V_{DD} = 5.0V$ ,  $GND = 0V$ ,  $T_A = 25^\circ C$ )

Symbol	Parameter	Min.	Typ.	Max.	Unit	Conditions
$t_{CYCE}$	Enable Cycle Time	500	-	-	ns	Figure 2
$t_{WHE}$	Enable "H" Level Pulse Width	300	-	-	ns	Figure 2
$t_{RE}$ , $t_{FE}$	Enable Rise/Fall Time	-	-	25	ns	Figure 2
$t_{AS}$	RS, R/W Setup Time	$60^1$	-	-	ns	Figure 2
		$100^2$				
$t_{AH}$	RS, R/W Address Hold Time	10	-	-	ns	Figure 2
$t_{DS}$	Data Output Delay	100	-	-	ns	Figure 2
$t_{DHW}$	Data Hold Time	10	-	-	ns	Figure 2

Notes: 1: 8-bit operation mode  
2: 4-bit operation mode

# Built-in Font Table

Lower 4 Bits \ Upper 4 Bits	0000	0001	0010	0011	0100	0101	0110	0111	1000	1001	1010	1011	1100	1101	1110	1111
xxxx0000	CG RAM (1)			0	a	P	`	P				-	夕	三	α	ρ
xxxx0001	(2)		!	1	A	Q	a	q			。	ア	チ	△	△	q
xxxx0010	(3)		"	2	B	R	b	r			「	イ	ツ	×	ρ	θ
xxxx0011	(4)		#	3	C	S	c	s			」	ウ	テ	モ	ε	ε
xxxx0100	(5)		\$	4	D	T	d	t			、	イ	ト	ト	μ	Ω
xxxx0101	(6)		%	5	E	U	e	u			・	オ	ナ	1	ε	Ω
xxxx0110	(7)		&	6	F	V	f	v			ヲ	カ	ニ	ヨ	ρ	Σ
xxxx0111	(8)		'	7	G	W	g	w			フ	キ	ヌ	ラ	g	π
xxxx1000	(1)		<	8	H	X	h	x			イ	ク	ネ	リ	γ	Σ
xxxx1001	(2)		>	9	I	Y	i	y			ウ	ケ	ル	ル	γ	γ
xxxx1010	(3)		*	:	J	Z	j	z			エ	コ	ハ	レ	j	≠
xxxx1011	(4)		+	;	K	[	k	<			オ	サ	ヒ	ロ	*	π
xxxx1100	(5)		,	<	L	¥	l	l			カ	シ	フ	ク	φ	π
xxxx1101	(6)		-	=	M	]	m	>			ユ	ス	ハ	ン	≠	÷
xxxx1110	(7)		.	>	N	^	n	→			ヨ	セ	ホ	ッ	π	
xxxx1111	(8)		/	?	O	_	o	+			ッ	ソ	マ	°	ö	■

## Example Initialization Program

```
'INIT-----  
A = &H30  
Call Writecom                                     'wake up  
Waitms 100  
Call Writecom                                     'wake up  
Waitms 10  
Call Writecom                                     'wake up  
Waitms 10  
A = &H38  
'function set  
Call Writecom  
A = &H10  
'shift display=no  
Call Writecom  
A = &H0C  
'display on  
Call Writecom  
A = &H06  
'entry mode set  
Call Writecom  
'-----  
Sub Writecom  
P1 = A  
Reset P3.0  
'instruction  
Reset P3.7  
'RW  
Waitms 1  
Set P3.4  
'E  
Waitms 1  
Reset P3.4                                     'E  
End Sub  
'-----  
Sub Writedata  
P1 = A  
Set P3.0  
'data  
Reset P3.7  
'RW  
Waitms 1  
Set P3.4  
'E  
Waitms 1  
Reset P3.4                                     'E  
End Sub  
'-----
```

## Quality Information

Test Item	Content of Test	Test Condition	Note
High Temperature storage	Endurance test applying the high storage temperature for a long time.	+80°C , 48hrs	2
Low Temperature storage	Endurance test applying the low storage temperature for a long time.	-30°C , 48hrs	1,2
High Temperature Operation	Endurance test applying the electric stress (voltage & current) and the high thermal stress for a long time.	+70°C , 48hrs	2
Low Temperature Operation	Endurance test applying the electric stress (voltage & current) and the low thermal stress for a long time.	-20°C , 48hrs	1,2
High Temperature / Humidity Operation	Endurance test applying the electric stress (voltage & current) and the high thermal with high humidity stress for a long time.	+40°C , 90% RH , 96hrs	1,2
Thermal Shock resistance	Endurance test applying the electric stress (voltage & current) during a cycle of low and high thermal stress.	0°C,30min -> 25°C,5min -> 50°C,30min = 1 cycle 10 cycles	
Vibration test	Endurance test applying vibration to simulate transportation and use.	10-55Hz , 15mm amplitude. 60 sec in each of 3 directions X,Y,Z For 15 minutes	3
Static electricity test	Endurance test applying electric static discharge.	VS=800V, RS=1.5kΩ, CS=100pF One time	

**Note 1:** No condensation to be observed.

**Note 2:** Conducted after 4 hours of storage at 25°C, 0%RH.

**Note 3:** Test performed on product itself, not inside a container.

## Precautions for using LCDs/LCMs

See Precautions at [www.newhavendisplay.com/specs/precautions.pdf](http://www.newhavendisplay.com/specs/precautions.pdf)

## Warranty Information and Terms & Conditions

[http://www.newhavendisplay.com/index.php?main\\_page=terms](http://www.newhavendisplay.com/index.php?main_page=terms)