



Chipsmall Limited consists of a professional team with an average of over 10 year of expertise in the distribution of electronic components. Based in Hongkong, we have already established firm and mutual-benefit business relationships with customers from,Europe,America and south Asia,supplying obsolete and hard-to-find components to meet their specific needs.

With the principle of "Quality Parts,Customers Priority,Honest Operation,and Considerate Service",our business mainly focus on the distribution of electronic components. Line cards we deal with include Microchip,ALPS,ROHM,Xilinx,Pulse,ON,Everlight and Freescale. Main products comprise IC,Modules,Potentiometer,IC Socket,Relay,Connector.Our parts cover such applications as commercial,industrial, and automotives areas.

We are looking forward to setting up business relationship with you and hope to provide you with the best service and solution. Let us make a better world for our industry!



## Contact us

Tel: +86-755-8981 8866 Fax: +86-755-8427 6832

Email & Skype: info@chipsmall.com Web: www.chipsmall.com

Address: A1208, Overseas Decoration Building, #122 Zhenhua RD., Futian, Shenzhen, China



# NHD-C0220BiZ-FS(RGB)-FBW-3VM

## COG (Chip-On-Glass) Character Liquid Crystal Display Module

NHD-	Newhaven Display
C0220-	COG 2 lines x 20 characters
BiZ-	Model, with I2C interface
F-	Transflective
S(RGB)-	Side LED backlights – Red, Green, and Blue
F-	FSTN (+)
B-	6:00 view
W-	Wide Temp (-20°C ~ +70°C)
3V-	3.3V power supply
M-	with Mounting holes
	<b>RoHS Compliant</b>

**Newhaven Display International, Inc.**

2511 Technology Drive, Suite 101

Elgin IL, 60124

Ph: 847-844-8795

Fax: 847-844-8796

[www.newhavendisplay.com](http://www.newhavendisplay.com)

[nhtech@newhavendisplay.com](mailto:nhtech@newhavendisplay.com)

[nhsales@newhavendisplay.com](mailto:nhsales@newhavendisplay.com)

## Document Revision History

Revision	Date	Description	Changed by
0	7/8/2009	Initial Release	CL
1	7/10/2009	Mechanical Drawing updated	BE
2	9/8/2009	Backlight supply current	BE
3	10/9/2009	Updated Electrical Characteristics	MC
4	12/9/2009	Updated Backlight Power supply and Current	MC
5	5/27/2011	Display character address code updated	AK
6	6/13/2011	Electrical characteristics updated	AK

## Functions and Features

- 2 lines x 20 characters
- Built-in ST7036i controller with I2C interface
- 3.3V power supply
- 1/16 duty, 1/5 bias
- Built-in DC supply for VLCD (requires 2 external capacitors)

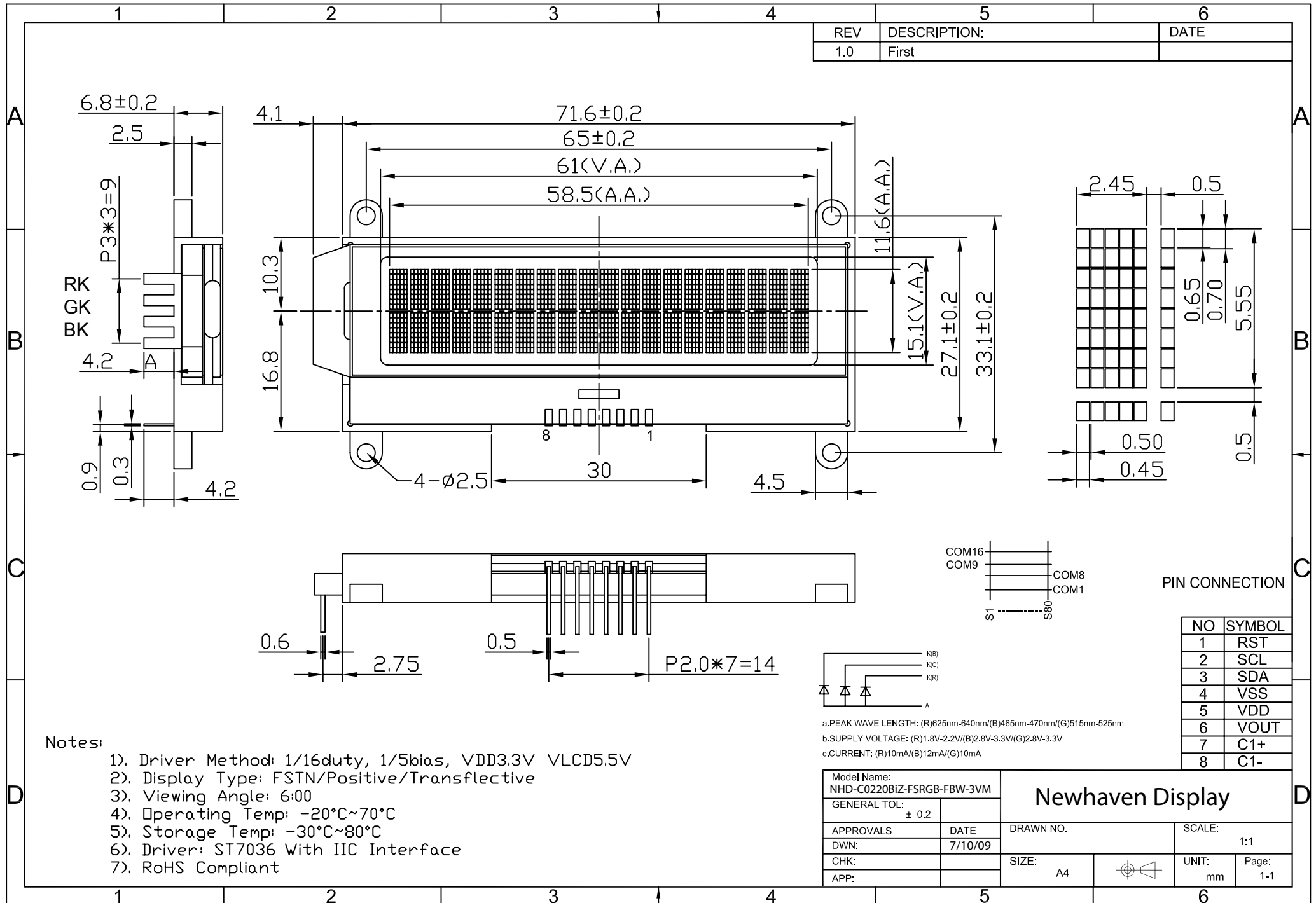

REV	DESCRIPTION:	DATE
1.0	First	

Notes:

- 1). Driver Method: 1/16duty, 1/5bias, VDD3.3V VLCD5.5V
- 2). Display Type: FSTN/Positive/Transflective
- 3). Viewing Angle: 6:00
- 4). Operating Temp: -20°C~70°C
- 5). Storage Temp: -30°C~80°C
- 6). Driver: ST7036 With IIC Interface
- 7). RoHS Compliant

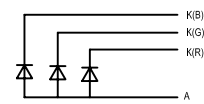

a. PEAK WAVE LENGTH: (R)625nm-640nm/(B)465nm-470nm/(G)515nm-525nm  
 b. SUPPLY VOLTAGE: (R)1.8V-2.2V/(B)2.8V-3.3V/(G)2.8V-3.3V  
 c. CURRENT: (R)10mA/(B)12mA/(G)10mA

Model Name: NHD-C0220BiZ-FSRGB-FBW-3VM		<b>Newhaven Display</b>	
GENERAL TOL: ± 0.2			
APPROVALS	DATE	DRAWN NO.	SCALE:
DWN:	7/10/09		1:1
CHK:		SIZE:	UNIT:
APP:		A4	mm
			Page:
			1-1

## Pin Description and Wiring Diagram

Pin No.	Symbol	External Connection	Function Description
1	RST	MPU	Active LOW Reset
2	SCL	MPU	Serial Clock (requires pull-up resistor)
3	SDA	MPU	Serial Data (requires pull-up resistor)
4	VSS	Power Supply	GND
5	VDD	Power Supply	+3.3V
6	VOUT	CAP	Voltage booster circuit – connect to 1uF cap to VSS or VDD
7	C1+	CAP	Connect to 1uF cap to PIN8
8	C1-	CAP	Connect to 1uF cap to PIN7

**Recommended LCD connector:** 2.0mm pitch pins, solder directly into PCB

**Backlight connector:** 3.0mm pitch pins, solder directly into PCB **Mates with:** ---

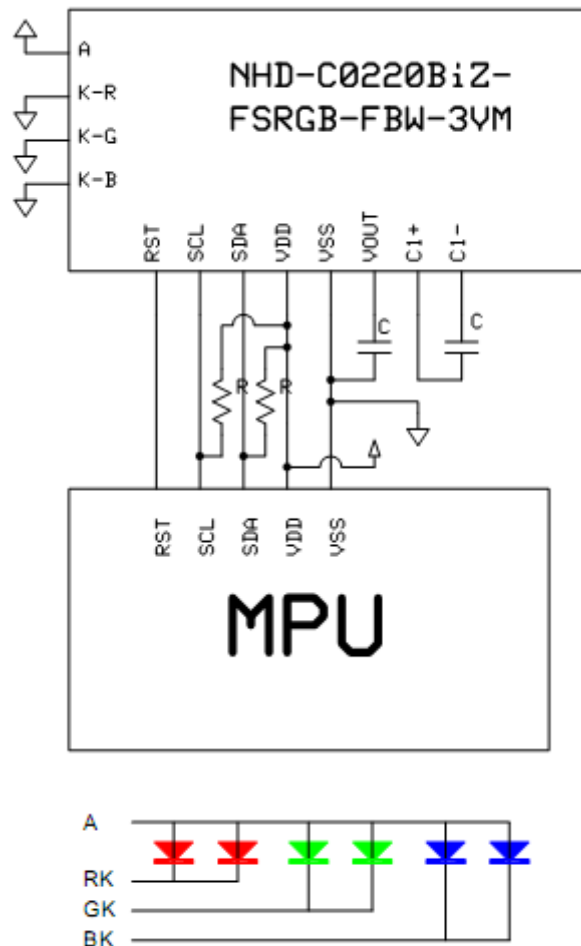

Capacitance 0.47uF~2.2uF

Recommended value = 1uF

## Electrical Characteristics

Item	Symbol	Condition	Min.	Typ.	Max.	Unit
Operating Temperature Range	Top	Absolute Max	-20	-	+70	°C
Storage Temperature Range	Tst	Absolute Max	-30	-	+80	°C
Supply Voltage	VDD		2.7	3.3	3.5	V
Supply Current	IDD	VDD=3.3V		1		mA
Supply for LCD (contrast)	VDD-V0	<b>VLCD=VDD-V0</b>	2.7		7.0	V
"H" Level input	Vih		0.7VDD	-	VDD	V
"L" Level input	Vil		0	-	0.8	V
"H" Level output	Voh		0.7VDD	-	VDD	V
"L" Level output	Vol		-	-	0.8	V
Backlight Supply Voltage – RED	VLED	-		1.9		V
Backlight Supply Current – RED	Iled	-		17	30	mA
Backlight Supply Voltage – GREEN	VLED	-		3.0		V
Backlight Supply Current – GREEN	Iled	-		17	30	mA
Backlight Supply Voltage – BLUE	VLED	-		3.0		V
Backlight Supply Current – BLUE	Iled	-		10	30	mA

## Optical Characteristics

Item	Symbol	Condition	Min.	Typ.	Max.	Unit
Viewing Angle - Vertical	AV	Cr ≥ 2	-60		+35	°
Viewing Angle - Horizontal	AH	Cr ≥ 2	-40		+40	°
Contrast Ratio	Cr		-	6	-	
Response Time (rise)	Tr	-	-	150	200	ms
Response Time (fall)	Tf	-	-	150	200	ms

## Controller Information

Built-in ST7036i. Download specification at [http://www.newhavendisplay.com/app\\_notes/ST7036.pdf](http://www.newhavendisplay.com/app_notes/ST7036.pdf)

# Slave Address = 0x78

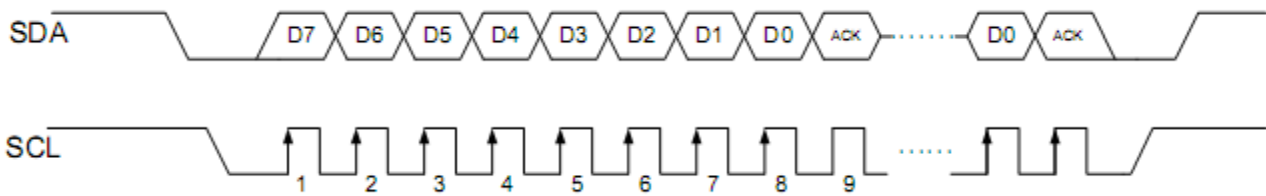
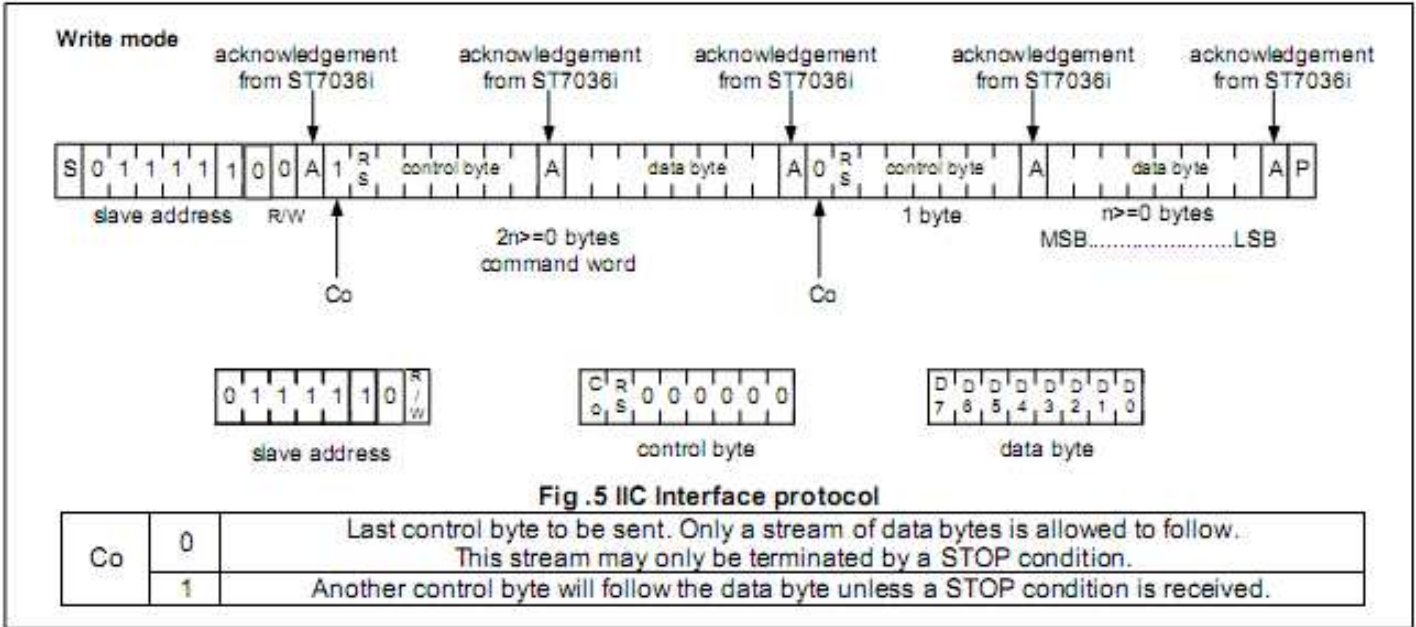

## Table of Commands

Instruction	Instruction Code										Description	
	RS	R/W	DB7	DB6	DB5	DB4	DB3	DB2	DB1	DB0		
Clear Display	0	0	0	0	0	0	0	0	0	0	1	Write "20H" to DDRAM, and set DDRAM address to "00H" from AC
Return Home	0	0	0	0	0	0	0	0	0	1	x	Set DDRAM address to "00H" from AC and return cursor to its original position if shifted. The contents of DDRAM are not changed.
Entry Mode Set	0	0	0	0	0	0	0	0	1	I/D	S	Sets cursor move direction and specifies display shift. These operations are performed during data write and read.
Display ON/OFF	0	0	0	0	0	0	0	1	D	C	B	D=1:entire display on C=1:cursor on B=1:cursor position on
Function Set	0	0	0	0	1	DL	N	DH	IS2	IS1		DL: interface data is 8/4 bits N: number of line is 2/1 DH: double height font IS[2:1]: instruction table select
Set DDRAM Address	0	0	1	AC6	AC5	AC4	AC3	AC2	AC1	AC0		Set DDRAM address in address counter
Read Busy Flag and Address	0	1	BF	AC6	AC5	AC4	AC3	AC2	AC1	AC0		Whether during internal operation or not can be known by reading BF. The contents of address counter can also be read.
Write Data to RAM	1	0	D7	D6	D5	D4	D3	D2	D1	D0		Write data into internal RAM (DDRAM/CGRAM/ICONRAM)
Read Data from RAM	1	1	D7	D6	D5	D4	D3	D2	D1	D0		Read data from internal RAM (DDRAM/CGRAM/ICONRAM)



Instruction table 0(IS[2:1]=[0,0])											
Cursor or Display Shift	0	0	0	0	0	1	S/C	R/L	X	X	S/C and R/L: Set cursor moving and display shift control bit, and the direction, without changing DDRAM data.
Set CGRAM	0	0	0	1	AC5	AC4	AC3	AC2	AC1	AC0	Set CGRAM address in address counter

Instruction table 1(IS[2:1]=[0,1])											
Bias Set	0	0	0	0	0	1	BS	1	0	FX	BS=1:1/4 bias BS=0:1/5 bias FX: fixed on high in 3-line application and fixed on low in other applications.
Set ICON Address	0	0	0	1	0	0	AC3	AC2	AC1	AC0	Set ICON address in address counter.
Power/ICON Control/ Contrast Set	0	0	0	1	0	1	Ion	Bon	C5	C4	Ion: ICON display on/off Bon: set booster circuit on/off C5,C4: Contrast set for internal follower mode.
Follower Control	0	0	0	1	1	0	Fon	Rab2	Rab1	Rab0	Fon: set follower circuit on/off Rab2~0: select follower amplified ratio.
Contrast Set	0	0	0	1	1	1	C3	C2	C1	C0	Contrast set for internal follower mode.

Instruction table 2(IS[2:1]=[1,0])											
Double Height Position Select	0	0	0	0	0	1	UD	X	x	x	UD: Double height position select
Reserved	0	0	0	1	X	X	X	X	X	X	Do not use (reserved for test)

## Display Character Address Code

1	2	3	4	5	6	7	8	9	10	11	12	13	14	15	16	17	18	19	20
00	01	02	03	04	05	06	07	08	09	0A	0B	0C	0D	0E	0F	10	11	12	13
40	41	42	43	44	45	46	47	48	49	4A	4B	4C	4D	4E	4F	50	51	52	53

Built-in Font Table (OPR1 = 0, OPR2 = 0)

b7-b4 b3-b0	0000	0001	0010	0011	0100	0101	0110	0111	1000	1001	1010	1011	1100	1101	1110	1111
0000																
0001																
0010																
0011																
0100																
0101																
0110																
0111																
1000																
1001																
1010																
1011																
1100																
1101																
1110																
1111																

## Example Initialization Program

```

/*****
*           Initialization For ST7036i           *
*****/
void init_LCD()
{
I2C_Start();
I2C_out(Slave); //Slave=0x78
I2C_out(Comsend); //Comsend = 0x00
I2C_out(0x38);
delay(10);
I2C_out(0x39);
delay(10);
I2C_out(0x14);
I2C_out(0x78);
I2C_out(0x5E);
I2C_out(0x6D);
I2C_out(0x0C);
I2C_out(0x01);
I2C_out(0x06);
delay(10);
I2C_Stop();
}
/*****/

/*****
*           Output command or data via I2C           *
*****/
void I2C_out(unsigned char j)           //I2C Output
{
    int n;
    unsigned char d;
    d=j;
    for(n=0;n<8;n++){
        if((d&0x80)==0x80)
            SDA=1;
        else
            SDA=0;
        d=(d<<1);
        SCL = 0;
        SCL = 1;
        SCL = 0;
    }
    SCL = 1;
    while(SDA==1){
        SCL=0;
        SCL=1;
    }
    SCL=0;
}
/*****/

/*****
*           I2C Start           *
*****/
```

```

*****/
void I2C_Start(void)
{
    SCL=1;
    SDA=1;
    SDA=0;
    SCL=0;
}
/*****/

/*****
*           I2C Stop           *
*****/
void I2C_Stop(void)
{
    SDA=0;
    SCL=0;
    SCL=1;
    SDA=1;
}
/*****/

/*****
*           Send string of ASCII data to LCD           *
*****/
void Show(unsigned char *text)
{
    int n,d;
    d=0x00;
    I2C_Start();
    I2C_out(Slave); //Slave=0x78
    I2C_out(Datasend); //Datasend=0x40
    for(n=0;n<20;n++){
        I2C_out(*text);
        ++text;
    }
    I2C_Stop();
}
/*****/
/*****/
/*****/

```

## Quality Information

Test Item	Content of Test	Test Condition	Note
High Temperature storage	Endurance test applying the high storage temperature for a long time.	+80°C , 200hrs	2
Low Temperature storage	Endurance test applying the low storage temperature for a long time.	-30°C , 200hrs	1,2
High Temperature Operation	Endurance test applying the electric stress (voltage & current) and the high thermal stress for a long time.	+70°C 200hrs	2
Low Temperature Operation	Endurance test applying the electric stress (voltage & current) and the low thermal stress for a long time.	-20°C , 200hrs	1,2
High Temperature / Humidity Operation	Endurance test applying the electric stress (voltage & current) and the high thermal with high humidity stress for a long time.	+60°C , 90% RH , 96hrs	1,2
Thermal Shock resistance	Endurance test applying the electric stress (voltage & current) during a cycle of low and high thermal stress.	-20°C,30min -> 25°C,5min -> 70°C,30min = 1 cycle 10 cycles	
Vibration test	Endurance test applying vibration to simulate transportation and use.	10-55Hz , 15mm amplitude. 60 sec in each of 3 directions X,Y,Z For 15 minutes	3
Static electricity test	Endurance test applying electric static discharge.	VS=800V, RS=1.5kΩ, CS=100pF One time	

**Note 1:** No condensation to be observed.

**Note 2:** Conducted after 4 hours of storage at 25°C, 0%RH.

**Note 3:** Test performed on product itself, not inside a container.

## Precautions for using LCDs/LCMs

See Precautions at [www.newhavendisplay.com/specs/precautions.pdf](http://www.newhavendisplay.com/specs/precautions.pdf)

## Warranty Information and Terms & Conditions

[http://www.newhavendisplay.com/index.php?main\\_page=terms](http://www.newhavendisplay.com/index.php?main_page=terms)