



Chipsmall Limited consists of a professional team with an average of over 10 year of expertise in the distribution of electronic components. Based in Hongkong, we have already established firm and mutual-benefit business relationships with customers from,Europe,America and south Asia,supplying obsolete and hard-to-find components to meet their specific needs.

With the principle of "Quality Parts,Customers Priority,Honest Operation,and Considerate Service",our business mainly focus on the distribution of electronic components. Line cards we deal with include Microchip,ALPS,ROHM,Xilinx,Pulse,ON,Everlight and Freescale. Main products comprise IC,Modules,Potentiometer,IC Socket,Relay,Connector.Our parts cover such applications as commercial,industrial, and automotives areas.

We are looking forward to setting up business relationship with you and hope to provide you with the best service and solution. Let us make a better world for our industry!



Contact us

Tel: +86-755-8981 8866 Fax: +86-755-8427 6832

Email & Skype: info@chipsmall.com Web: www.chipsmall.com

Address: A1208, Overseas Decoration Building, #122 Zhenhua RD., Futian, Shenzhen, China



NHD-C12864WO-B1TTI#-M

COG (Chip-On-Glass) Liquid Crystal Display Module

NHD-	Newhaven Display
C12864-	128 x 64 pixels
WO-	Display Type: COG
B1-	Model
T-	White LED backlight
T-	FSTN (Negative)
I#-	Transmissive, Wide Temp (-20°C ~ +70°C), 6:00 view
M-	Mounting Holes
	RoHS Compliant

Newhaven Display International, Inc.

2511 Technology Drive, Suite 101

Elgin IL, 60124

Ph: 847-844-8795

Fax: 847-844-8796

www.newhavendisplay.com

nhtech@newhavendisplay.com

nhsales@newhavendisplay.com

Document Revision History

Revision	Date	Description	Changed by
0	9/1/2008	Initial Release	-
1	2/26/2010	User guide reformat	MC
2	3/9/2010	Block diagram updated	BE
3	5/4/2010	Block diagram and Pin description update	MP
4	5/5/2010	Backlight connector updated	BE
5	5/14/2010	Pin description update	MP
6	5/2/2011	Example initialization code updated	AK
7	5/13/2011	Block diagram updated	AK
8	5/19/2011	Block diagram & Pin description updated	AK
9	1/10/2012	Pin description & Controller link updated	AK
10	6/15/2012	Timing characteristics updated	AK
11	4/4/2013	Backlight mating connector, LCD voltage levels updated	AK

Functions and Features

- 128 x 64 pixels
- Built-in ST7565P-G controller
- +3.3V power supply
- 1/65 duty cycle; 1/9 bias
- RoHS Compliant

Mechanical Drawing

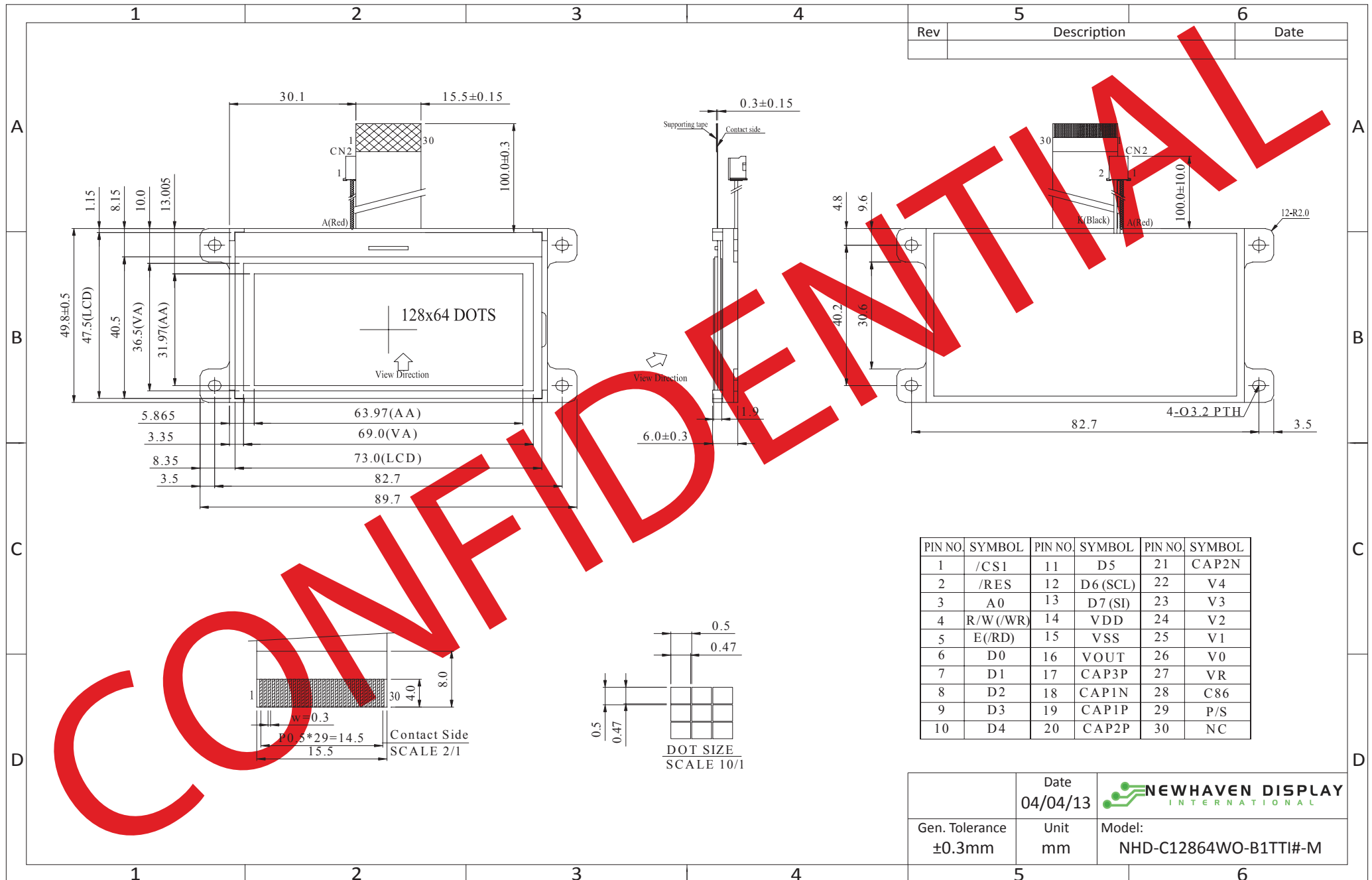

Rev	Description	Date

	Date 04/04/13	
Gen. Tolerance ±0.3mm	Unit mm	

The drawing contained herein is the exclusive property of Newhaven Display International, Inc. and shall not be copied, reproduced, and/or disclosed in any format without permission.

Pin Description and Wiring Diagram

Pin No.	Symbol	External Connection	Function Description
1	/CS1	MPU	Active LOW chip select
2	/RES	MPU	Active LOW Reset signal
3	A0	MPU	Register select signal. 0: instruction; 1: data
4	R/W (/WR)	MPU	Read/write select signal. R/W=1: Read R/W=0: Write
5	E (/RD)	MPU	Operation enable signal. Falling edge triggered.
6-13	DB0~DB7	MPU	In parallel interface: 8-bit-directional data bus In serial interface: DB0~DB5 = VDD or NC D6 = Serial clock D7 = Serial data
14	VDD	Power Supply	Power supply for logic (+3.3V)
15	VSS	Power Supply	Ground
16	VOUT	Power Supply	2.2uF cap to VSS
17	CAP3P	Power Supply	2.2uF cap to CAP1N (pin-18)
18	CAP1N	Power Supply	2.2uF cap to CAP3P (pin-17) and CAP1P (pin-19)
19	CAP1P	Power Supply	2.2uF cap to CAP1N (pin-18)
20	CAP2P	Power Supply	2.2uF cap to CAP2N (pin-21)
21	CAP2N	Power Supply	2.2uF cap to CAP2P (pin-20)
22-26	V4~V0	Power Supply	2.2uF cap to VDD or VSS
27	VR	Adj Power Supply	Wiper of 10kΩ pot (see schematic below)
28	C86	MPU	Select MPU interface pin. C86= H:6800; C86= L:8080
29	P/S	MPU	Parallel/Serail select. PS= H: Parallel; PS= L: Serial
30	NC	-	No connect

Recommended LCD connector: 0.5mm Pitch, 30 pin FFC. Molex p/n: 52892-3095

Backlight connector: A2001H-02P

Mates with: A2001WR-2P, A2001WR-S-2P, A2001WV-2P, A2001WV-S-2P

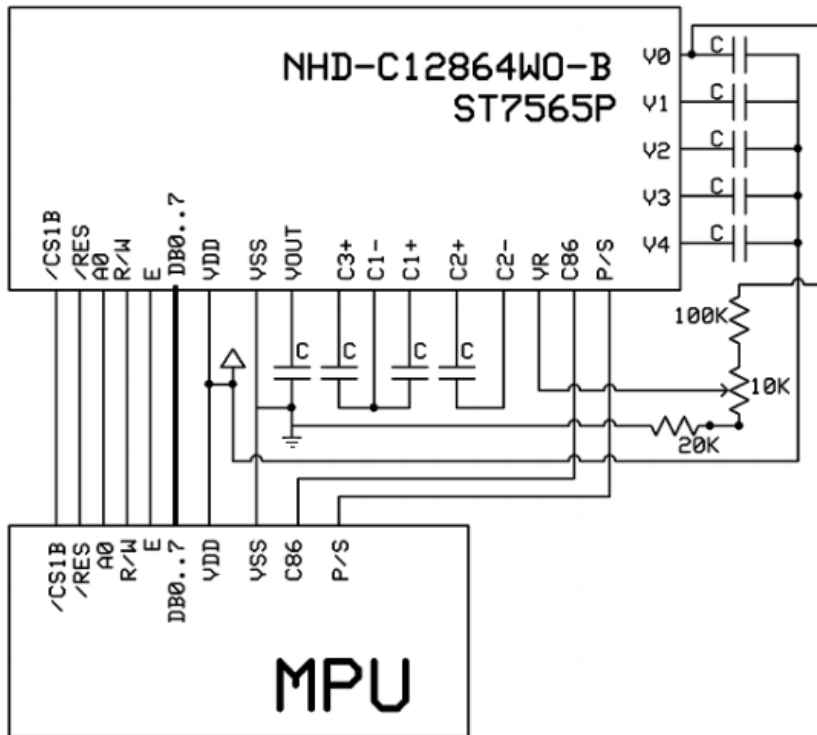

Electrical Characteristics

Item	Symbol	Condition	Min.	Typ.	Max.	Unit
Operating Temperature Range	TOP	Absolute Max	-20	-	+70	°C
Storage Temperature Range	TST	Absolute Max	-30	-	+80	°C
Supply Voltage	VDD		3.0	-	3.3	V
Supply Current	IDD	Ta=25°C, VDD=3.3V	-	0.6	2.0	mA
Supply for LCD (contrast)	VDD-V0	Ta=25°C	9.2	9.45	9.7	V
"H" Level input	Vih		0.8*VDD	-	VDD	V
"L" Level input	Vil		VSS	-	0.2*VDD	V
"H" Level output	Voh		0.8*VDD	-	VDD	V
"L" Level output	Vol		VSS	-	0.2*VDD	V
LED Backlight voltage	VLED		3.4	3.5	3.6	V
LED Backlight current	ILED	VLED=3.5V	61.2	72	100	mA

Optical Characteristics

Item	Symbol	Condition	Min.	Typ.	Max.	Unit
Viewing Angle – Top		CR ≥ 2	-	20	-	°
Viewing Angle – Bottom			-	40	-	°
Viewing Angle – Left			-	40	-	°
Viewing Angle – Right			-	40	-	°
Contrast Ratio	CR		-	5	-	-
Response Time (rise)	Tr		-	100	280	ms
Response Time (fall)	Tf		-	180	330	ms

Controller Information

Built-in ST7565P-G controller

Please download specification at http://www.newhavendisplay.com/app_notes/ST7565P.pdf

Table of Commands

Command	Command Code										Function		
	A0	/RD	/WR	D7	D6	D5	D4	D3	D2	D1		D0	
(1) Display ON/OFF	0	1	0	1	0	1	0	1	1	1	0	1	LCD display ON/OFF 0: OFF, 1: ON
(2) Display start line set	0	1	0	0	1	Display start address						Sets the display RAM display start line address	
(3) Page address set	0	1	0	1	0	1	1	Page address					Sets the display RAM page address
(4) Column address set upper bit	0	1	0	0	0	0	1	Most significant column address				Sets the most significant 4 bits of the display RAM column address. Sets the least significant 4 bits of the display RAM column address.	
Column address set lower bit	0	1	0	0	0	0	0	Least significant column address					
(5) Status read	0	0	1	Status				0	0	0	0		Reads the status data
(6) Display data write	1	1	0	Write data								Writes to the display RAM	
(7) Display data read	1	0	1	Read data								Reads from the display RAM	
(8) ADC select	0	1	0	1	0	1	0	0	0	0	0	0	Sets the display RAM address SEG output correspondence 0: normal, 1: reverse
(9) Display normal/reverse	0	1	0	1	0	1	0	0	1	1	0	1	Sets the LCD display normal/reverse 0: normal, 1: reverse
(10) Display all points ON/OFF	0	1	0	1	0	1	0	0	1	0	0	1	Display all points 0: normal display 1: all points ON
(11) LCD bias set	0	1	0	1	0	1	0	0	0	1	0	1	Sets the LCD drive voltage bias ratio 0: 1/9 bias, 1: 1/7 bias (ST7565P)
(12) Read/modify/write	0	1	0	1	1	1	0	0	0	0	0	0	Column address increment At write: +1 At read: 0
(13) End	0	1	0	1	1	1	0	1	1	1	0		Clear read/modify/write
(14) Reset	0	1	0	1	1	1	0	0	0	1	0		Internal reset
(15) Common output mode select	0	1	0	1	1	0	0	0	1	*	*	*	Select COM output scan direction 0: normal direction 1: reverse direction
(16) Power control set	0	1	0	0	0	1	0	1	Operating mode				Select internal power supply operating mode
(17) V ₀ voltage regulator internal resistor ratio set	0	1	0	0	0	1	0	0	Resistor ratio				Select internal resistor ratio(Rb/Ra) mode
(18) Electronic volume mode set	0	1	0	1	0	0	0	0	0	0	0	1	Set the V ₀ output voltage electronic volume register
Electronic volume register set				0	0	Electronic volume value							
(20) Booster ratio set	0	1	0	1	1	1	1	1	0	0	0	0	select booster ratio 00: 2x,3x,4x 01: 5x 11: 6x
(21) Power saver													Display OFF and display all points ON compound command
(22) NOP	0	1	0	1	1	1	0	0	0	1	1		Command for non-operation
(23) Test	0	1	0	1	1	1	1	*	*	*	*		Command for IC test. Do not use this command

Timing Characteristics

System Bus Read/Write Characteristics 1 (For the 8080 Series MPU)

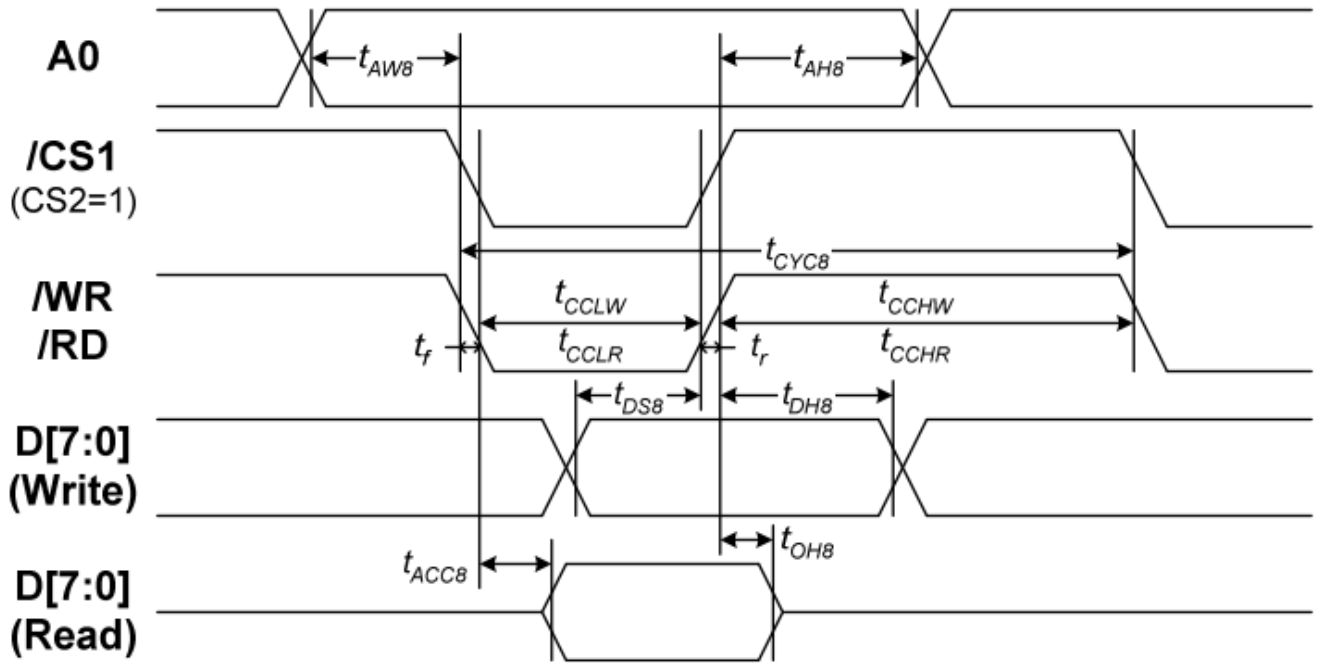

(V_{DD} = 3.3V, T_a = -30 to 85°C)

Item	Signal	Symbol	Condition	Rating		Units
				Min.	Max.	
Address hold time	A0	t _{AH8}		0	—	Ns
Address setup time		t _{AW8}		0	—	
System cycle time		t _{CYC8}		240	—	
Write L pulse width	/WR	t _{CCLW}		80	—	
Write H pulse width		t _{CCHW}		80	—	
Read L pulse width	/RD	t _{CCLR}		140	—	
Read H pulse width		t _{CCHR}		80	—	
Write Data setup time	D0 to D7	t _{DS8}		40	—	
Write Address hold time		t _{DH8}		0	—	
Read access time		t _{ACC8}	CL = 100 pF	—	70	
Read Output disable time		t _{OH8}	CL = 100 pF	5	50	

System Bus Read/Write Characteristics 2 (For the 6800 Series MPU)

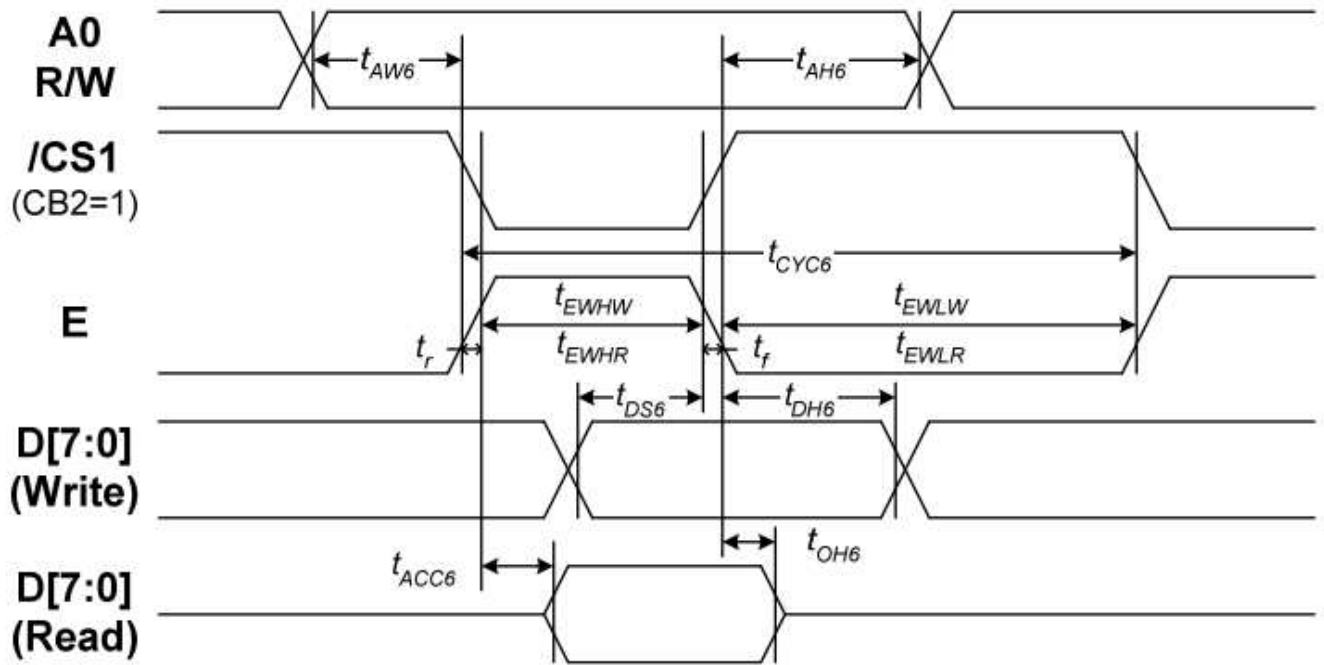

(V_{DD} = 3.3V, T_a = -30 to 85°C)

Item	Signal	Symbol	Condition	Rating		Units
				Min.	Max.	
Address hold time	A0	t _{AH6}		0	—	ns
Address setup time		t _{AW6}		0	—	
System cycle time		t _{CYC6}		240	—	
Enable L pulse width (WRITE)	E	t _{EWLW}		80	—	
Enable H pulse width (WRITE)		t _{EWHW}		80	—	
Enable L pulse width (READ)		t _{EWLR}		80	—	
Enable H pulse width (READ)		t _{EWHR}		140	—	
WRITE Data setup time	D0 to D7	t _{DS6}		40	—	
WRITE Address hold time		t _{DH6}		0	—	
READ access time		t _{ACC6}	CL = 100 pF	—	70	
READ Output disable time		t _{OH6}	CL = 100 pF	5	50	

The Serial Interface

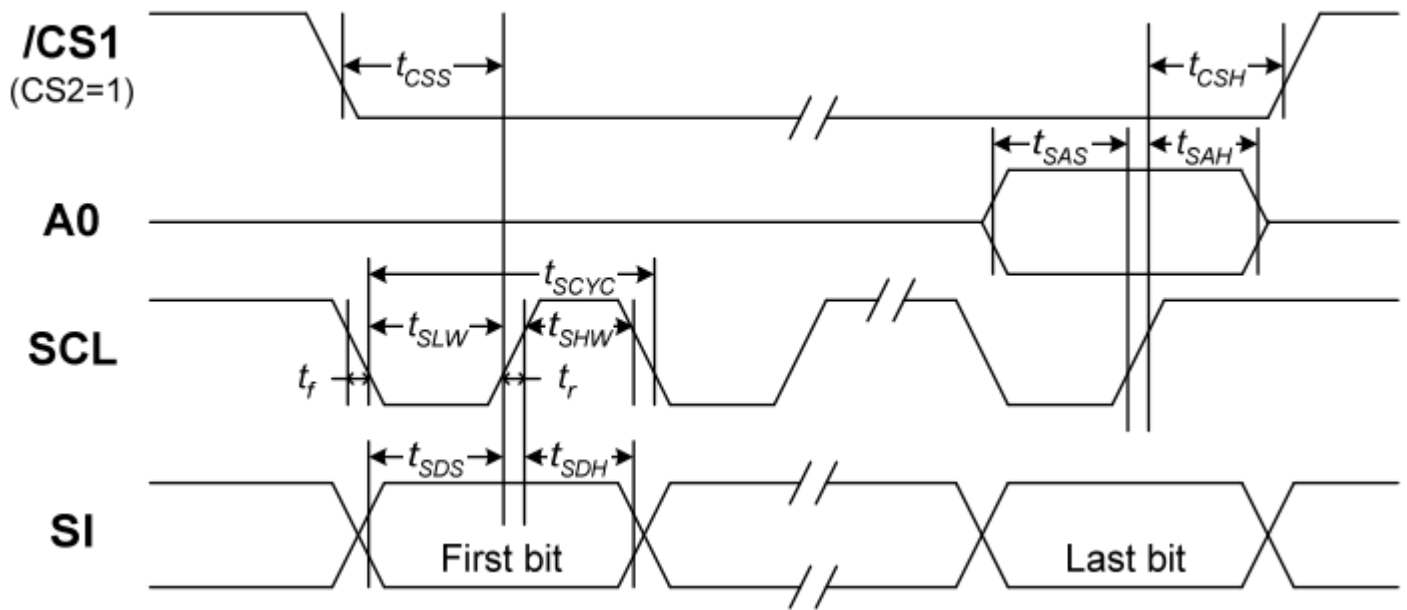

($V_{DD} = 3.3V$, $T_a = -30$ to $85^\circ C$)

Item	Signal	Symbol	Condition	Rating		Units
				Min.	Max.	
Serial Clock Period	SCL	t_{SCYC}		50	—	ns
SCL "H" pulse width		t_{SHW}		25	—	
SCL "L" pulse width		t_{SLW}		25	—	
Address setup time	A0	t_{SAS}		20	—	
Address hold time		t_{SAH}		10	—	
Data setup time	SI	t_{SDS}		20	—	
Data hold time		t_{SDH}		10	—	
CS-SCL time	CS	t_{CSS}		20	—	
CS-SCL time		t_{CSH}		40	—	

Example Initialization Program

```

/*****/
void comm_out(unsigned int c)
{
    CS1 = 0; //Active Low
    AO = 0; //LOW = instruction
    delay(1);
    WRT = 0; // /WR in 8080 mode; R/W in 6800 mode
    P1 = c;
    delay(1);
    WRT = 1; // /WR in 8080 mode; R/W in 6800 mode
    CS1 = 1; //inactive
}

void data_out(unsigned int d)
{
    CS1 = 0; //Active Low
    AO = 1; //High = Data
    delay(1);
    WRT = 0;
    P1 = d;
    delay(1);
    WRT = 1;
    CS1 = 1; //inactive
}

void init()
{
    //IRS pin is tied low internally - external resistor circuit must be used
    C86 = 1;           // Interface set to 8080 mode
    RDD = 1;          // /RD in 8080 mode; E in 6800 mode
    WRT = 1;          // /WR in 8080 mode; R/W in 6800 mode
    CS1 = 0;
    RST = 1;          // /RST in 8080 mode; /RES in 6800 mode
    RST = 0;          // /RST in 8080 mode; /RES in 6800 mode
    delay(2);
    RST = 1;          // /RST in 8080 mode; /RES in 6800 mode
    delay(2);
    comm_out(0xA2);   //added 1/9 bias
    comm_out(0xA0);   //ADC segment driver direction (A0=Normal)
    comm_out(0xC8);
    comm_out(0xC0);   //COM output scan direction (C0= Normal)
    comm_out(0x40);   //Operating Mode
    comm_out(0x25);   //resistor ratio
    comm_out(0x19);   //column address set upper bit
    comm_out(0x2F);   //select internal resistor ratio
    comm_out(0xAF);   //display ON/OFF - set to ON
}
/*****/

```

Quality Information

Test Item	Content of Test	Test Condition	Note
High Temperature storage	Endurance test applying the high storage temperature for a long time.	+80°C , 200hrs	2
Low Temperature storage	Endurance test applying the low storage temperature for a long time.	-30°C , 200hrs	1,2
High Temperature Operation	Endurance test applying the electric stress (voltage & current) and the high thermal stress for a long time.	+70°C 200hrs	2
Low Temperature Operation	Endurance test applying the electric stress (voltage & current) and the low thermal stress for a long time.	-20°C , 200hrs	1,2
High Temperature / Humidity Operation	Endurance test applying the electric stress (voltage & current) and the high thermal with high humidity stress for a long time.	+60°C , 90% RH , 96hrs	1,2
Thermal Shock resistance	Endurance test applying the electric stress (voltage & current) during a cycle of low and high thermal stress.	-20°C,30min -> 25°C,5min -> 70°C,30min = 1 cycle 10 cycles	
Vibration test	Endurance test applying vibration to simulate transportation and use.	10-55Hz , 15mm amplitude. 60 sec in each of 3 directions X,Y,Z For 15 minutes	3
Static electricity test	Endurance test applying electric static discharge.	VS=800V, RS=1.5kΩ, CS=100pF One time	

Note 1: No condensation to be observed.

Note 2: Conducted after 4 hours of storage at 25°C, 0%RH.

Note 3: Test performed on product itself, not inside a container.

Precautions for using LCDs/LCMs

See Precautions at www.newhavendisplay.com/specs/precautions.pdf

Warranty Information and Terms & Conditions

http://www.newhavendisplay.com/index.php?main_page=terms