



Chipsmall Limited consists of a professional team with an average of over 10 year of expertise in the distribution of electronic components. Based in Hongkong, we have already established firm and mutual-benefit business relationships with customers from,Europe,America and south Asia,supplying obsolete and hard-to-find components to meet their specific needs.

With the principle of “Quality Parts,Customers Priority,Honest Operation,and Considerate Service”,our business mainly focus on the distribution of electronic components. Line cards we deal with include Microchip,ALPS,ROHM,Xilinx,Pulse,ON,Everlight and Freescale. Main products comprise IC,Modules,Potentiometer,IC Socket,Relay,Connector.Our parts cover such applications as commercial,industrial, and automotives areas.

We are looking forward to setting up business relationship with you and hope to provide you with the best service and solution. Let us make a better world for our industry!



Contact us

Tel: +86-755-8981 8866 Fax: +86-755-8427 6832

Email & Skype: info@chipsmall.com Web: www.chipsmall.com

Address: A1208, Overseas Decoration Building, #122 Zhenhua RD., Futian, Shenzhen, China



NHD-C24064WO-ATFH-3V3

COG (Chip-On-Glass) Liquid Crystal Display Module

NHD-	Newhaven Display
C24064-	240 x 64 pixels
WO-	Model
A-	Transflective
T-	White LED backlight
F-	FSTN (+)
H-	6:00 view, Wide Temp (-20°C ~ +70°C)
3V3-	3.0Vdd, 3.5 Volt backlight

RoHS Compliant

Newhaven Display International, Inc.

2511 Technology Drive, Suite 101
Elgin IL, 60124
Ph: 847-844-8795 Fax: 847-844-8796

Document Revision History

Revision	Date	Description	Changed by
0	5/10/2007	Initial Release	-
1	9/23/2009	User guide reformat	BE
2	10/08/2009	Updated Backlight Information	MC
3	11/20/2009	Updated backlight supply current typ.	MC
4	8/26/2011	Mechanical Drawing Updated	TJ
5	2/3/2012	Controller link updated	AK
6	11/16/2012	Electrical characteristics & Wiring diagram updated	AK
7	4/4/2013	Backlight mating connector updated	AK

Functions and Features

- 240 x 64 pixels
- Built-in DUAL ST7565S controllers
- +3.0V power supply
- Parallel/Serial Interface
- RoHS Compliant

Mechanical Drawing

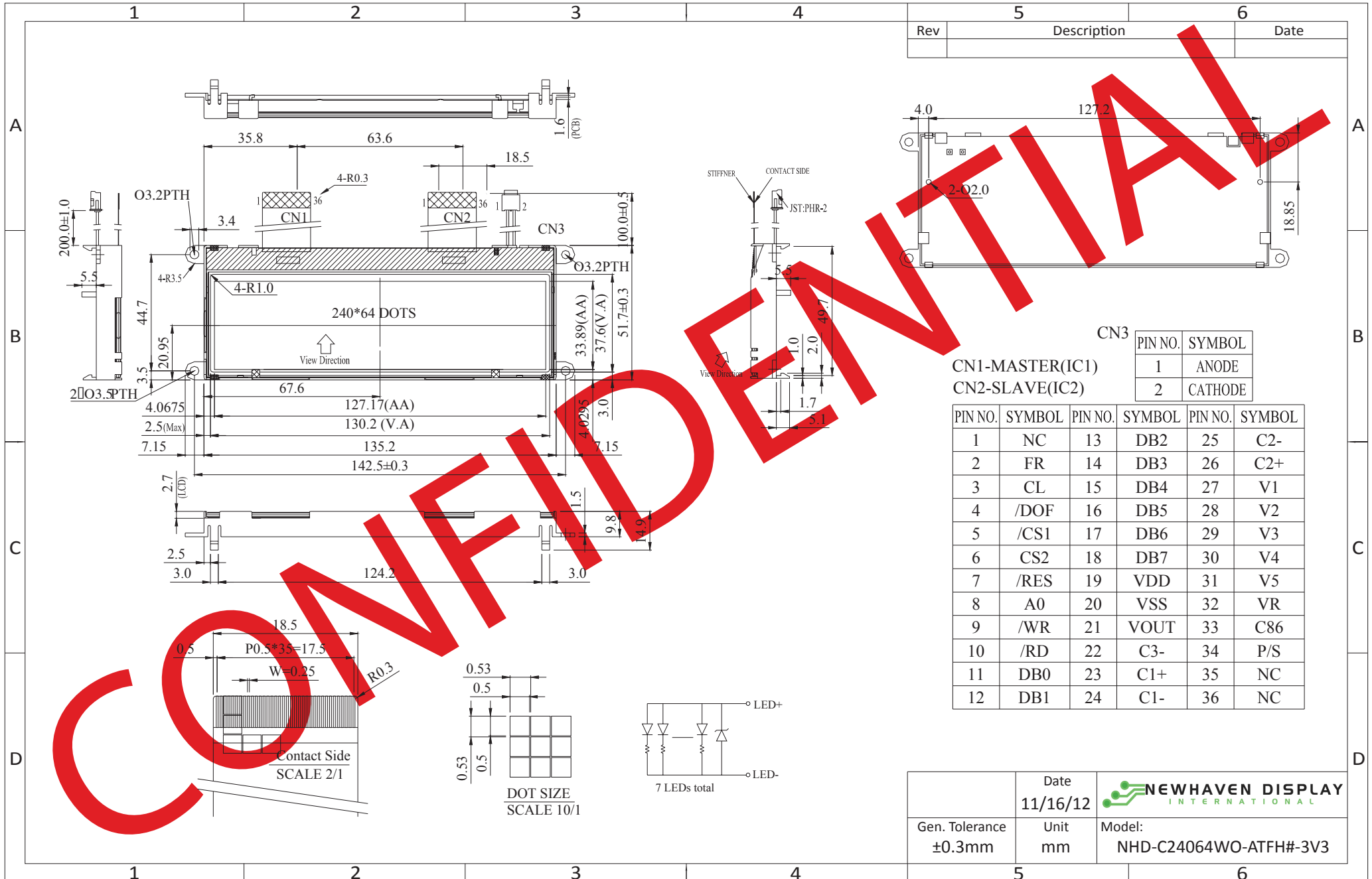

Rev	Description	Date

PIN NO.	SYMBOL
1	ANODE
2	CATHODE

PIN NO.	SYMBOL	PIN NO.	SYMBOL	PIN NO.	SYMBOL
1	NC	13	DB2	25	C2-
2	FR	14	DB3	26	C2+
3	CL	15	DB4	27	V1
4	/DOF	16	DB5	28	V2
5	/CS1	17	DB6	29	V3
6	CS2	18	DB7	30	V4
7	/RES	19	VDD	31	V5
8	A0	20	VSS	32	VR
9	/WR	21	VOUT	33	C86
10	/RD	22	C3-	34	P/S
11	DB0	23	C1+	35	NC
12	DB1	24	C1-	36	NC

	Date	 NEWHAVEN DISPLAY INTERNATIONAL
	11/16/12	
Gen. Tolerance	Unit	Model:
±0.3mm	mm	NHD-C24064WO-ATFH#-3V3

The drawing contained herein is the exclusive property of Newhaven Display International, Inc. and shall not be copied, reproduced, and/or disclosed in any format without permission.

Pin Description

Pin No.	Symbol	External Connection	Function Description
1	NC	-	No Connect
2	FR	-	Alternating current signal (tie both FR pins together)
3	CL	-	Clock input terminal (tie both CL pins together)
4	/DOF	-	Blanking control output (tie both /DOF pins together)
5	/CS1	MPU	Active LOW Chip Select Signal
6	CS2	MPU	Active HIGH Chip Select Signal (can tie HIGH)
7	/RES	MPU	Active LOW Reset signal
8	A0	MPU	Register Select. 0: Instruction; 1: Data
9	/WR R/W	MPU	In 8080 mode: Active LOW Write signal In 6800 mode: R/W=1 for Read; R/W=0 for Write
10	/RD E	MPU	In 8080 mode: Active LOW Read signal In 6800 mode: Enable signal; Falling edge triggered
11	DB0	MPU	Parallel Interface DB0-DB7: Bi-directional 8-bit data bus Serial Interface: DB0-DB5: No connect in serial mode DB6 = Serial clock DB7 = Serial data input
12	DB1		
13	DB2		
14	DB3		
15	DB4		
16	DB5		
17	DB6 (SCL)		
18	DB7 (SI)		
19	VDD	Power Supply	Supply Voltage for Logic (3.0V)
20	VSS	Power Supply	Ground
21	Vout	Power Supply	1.0uF Cap to GND
22	C3-	Power Supply	1.0uF-2.2uF cap to C1+ (Pin-23)
23	C1+	Power Supply	1.0uF-2.2uF cap to C3- (Pin-22) and C1- (Pin-24)
24	C1-	Power Supply	1.0uF-2.2uF cap to C1+ (Pin-23)
25	C2-	Power Supply	1.0uF-2.2uF cap to C2+ (Pin-26)
26	C2+	Power Supply	1.0uF-2.2uF cap to C2-(Pin-25)
27	V1	Power Supply	1.0uF-2.2uF cap to VDD
28	V2	Power Supply	1.0uF-2.2uF cap to VDD
29	V3	Power Supply	1.0uF-2.2uF cap to VDD
30	V4	Power Supply	1.0uF-2.2uF cap to VDD
31	V5	Power Supply	1.0uF-2.2uF cap to VDD
32	VR	-	No connection
33	C86	MPU	Select MPU interface pin. C86 = H: 6800; C86 = L: 8080
34	P/S	MPU	Parallel/Serial select. PS = H: Parallel; PS = L: Serial
35	NC	-	No connection
36	NC	-	No connection

Recommended LCD connectors: 0.5mm pitch pins. Molex p/n: 54132-3697

Backlight connector: A2001H-02P **Mates with:** A2001WR-2P, A2001WR-S-2P, A2001WV-2P, A2001WV-S-2P

Wiring Diagram

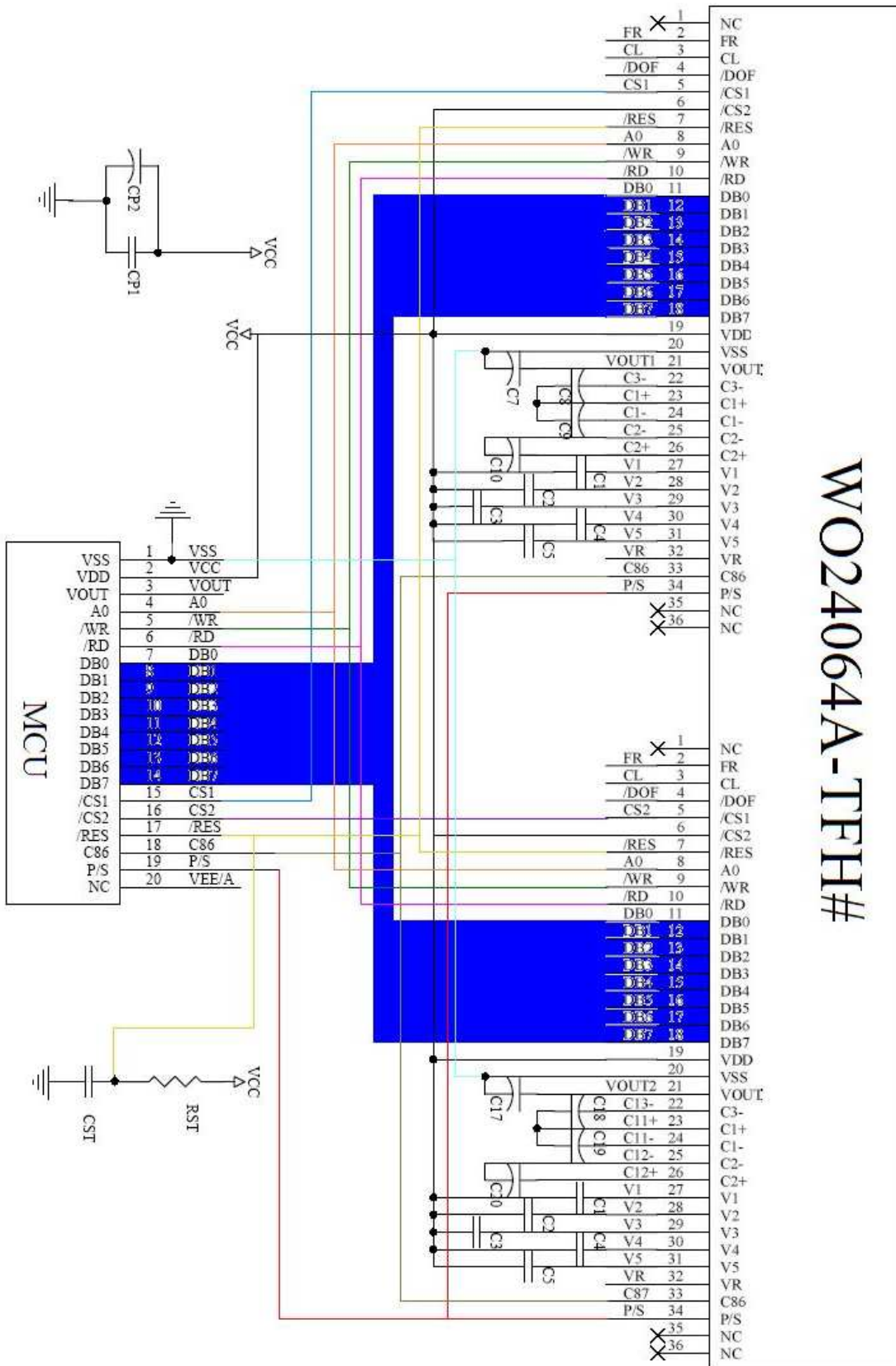

W024064A-TFH#

Electrical Characteristics

Item	Symbol	Condition	Min.	Typ.	Max.	Unit
Operating Temperature Range	Top	Absolute Max	-20	-	+70	°C
Storage Temperature Range	Tst	Absolute Max	-30	-	+80	°C
Supply Voltage	VDD		3.0	3.3	3.6	V
Supply Current	IDD	Ta=25°C, VDD=3.3V	-	1.5	2.5	mA
Supply for LCD (contrast)	VDD-V0	Ta=25°C	9.3	10	10.7	V
"H" Level input	Vih		0.8*VDD	-	VDD	V
"L" Level input	Vil		VSS	-	0.2*VDD	V
"H" Level output	Voh		0.8*VDD	-	VDD	V
"L" Level output	Vol		VSS	-	0.2*VDD	V
Backlight Supply Voltage	VLED		3.4	3.5	3.6	V
Backlight Supply current	ILED	VLED=3.5V	80	101	150	mA

Optical Characteristics

Item	Symbol	Condition	Min.	Typ.	Max.	Unit
Viewing Angle – Top		Cr≥2	-	30	-	°
Viewing Angle – Bottom			-	60	-	°
Viewing Angle – Left			-	45	-	°
Viewing Angle – Right			-	45	-	°
Contrast Ratio	CR		-	5	-	-
Response Time (rise)	Tr	-	-	200	300	ms
Response Time (fall)	Tf	-	-	200	300	ms

Controller Information

Built-in ST7565S controller.

Please download specification at http://www.newhavendisplay.com/app_notes/ST7565S.pdf

Table of Commands

Command	Command Code										Function	
	A0	/RD	/WR	D7	D6	D5	D4	D3	D2	D1		D0
(1) Display ON/OFF	0	1	0	1	0	1	0	1	1	1	0	LCD display ON/OFF 0: OFF, 1: ON
(2) Display start line set	0	1	0	0	1	Display start address						Sets the display RAM display start line address
(3) Page address set	0	1	0	1	0	1	1	Page address				Sets the display RAM page address
(4) Column address set upper bit	0	1	0	0	0	0	1	Most significant column address				Sets the most significant 4 bits of the display RAM column address. Sets the least significant 4 bits of the display RAM column address.
Column address set lower bit	0	1	0	0	0	0	0	Least significant column address				
(5) Status read	0	0	1	Status				0	0	0	0	Reads the status data
(6) Display data write	1	1	0	Write data							Writes to the display RAM	
(7) Display data read	1	0	1	Read data							Reads from the display RAM	
(8) ADC select	0	1	0	1	0	1	0	0	0	0	0	Sets the display RAM address SEG output correspondence 0: normal, 1: reverse
(9) Display normal/reverse	0	1	0	1	0	1	0	0	1	1	0	Sets the LCD display normal/reverse 0: normal, 1: reverse
(10) Display all points ON/OFF	0	1	0	1	0	1	0	0	1	0	0	Display all points 0: normal display 1: all points ON
(11) LCD bias set	0	1	0	1	0	1	0	0	0	1	0	Sets the LCD drive voltage bias ratio 0: 1/9 bias, 1: 1/7 bias (ST7565S)
(12) Read/modify/write	0	1	0	1	1	1	0	0	0	0	0	Column address increment At write: +1 At read: 0
(13) End	0	1	0	1	1	1	0	1	1	1	0	Clear read/modify/write
(14) Reset	0	1	0	1	1	1	0	0	0	1	0	Internal reset
(15) Common output mode select	0	1	0	1	1	0	0	0	*	*	*	Select COM output scan direction 0: normal direction 1: reverse direction
(16) Power control set	0	1	0	0	0	1	0	1	Operating mode			Select internal power supply operating mode
(17) V _s voltage regulator internal resistor ratio set	0	1	0	0	0	1	0	0	Resistor ratio			Select internal resistor ratio(R _b /R _a) mode
(18) Electronic volume mode set Electronic volume register set	0	1	0	1	0	0	0	0	0	0	1	Set the V _s output voltage electronic volume register
(19) Static indicator ON/OFF Static indicator register set	0	1	0	1	0	1	0	1	1	0	0	0: OFF, 1: ON Set the flashing mode
(20) Booster ratio set	0	1	0	1	1	1	1	1	0	0	0	select booster ratio 00: 2x,3x,4x 01: 5x 11: 6x
(21) Power saver												Display OFF and display all points ON compound command
(22) NOP	0	1	0	1	1	1	0	0	0	1	1	Command for non-operation
(23) Test	0	1	0	1	1	1	1	*	*	*	*	Command for IC test. Do not use this command

Timing Characteristics

System Bus Read/Write Characteristics 1 (For the 8080 Series MPU)

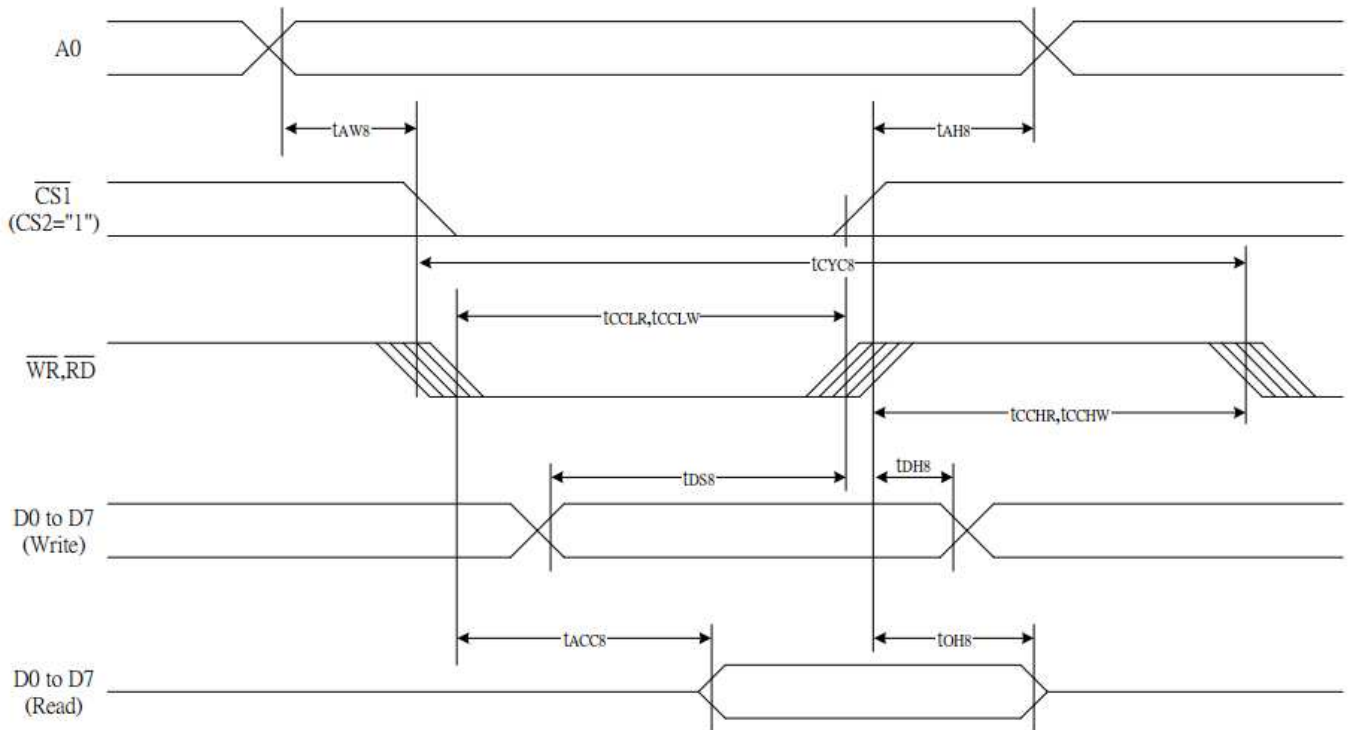

Item	Signal	Symbol	Condition	Rating		Units
				Min.	Max.	
Address hold time	A0	tAH8		0	—	Ns
Address setup time		tAW8		0	—	
System cycle time		tCYC8		240	—	
Enable L pulse width (WRITE)	WR	tCCLW		80	—	
Enable H pulse width (WRITE)		tCCHW		80	—	
Enable L pulse width (READ)	RD	tCCLR		140	—	
Enable H pulse width (READ)		tCCHR		80	—	
WRITE Data setup time	D0 to D7	tDSS		40	—	
WRITE Address hold time		tDH8		10	—	
READ access time		tACC8	CL = 100 pF	—	70	
READ Output disable time		tOH8	CL = 100 pF	5	50	

System Bus Read/Write Characteristics 2 (For the 6800 Series MPU)

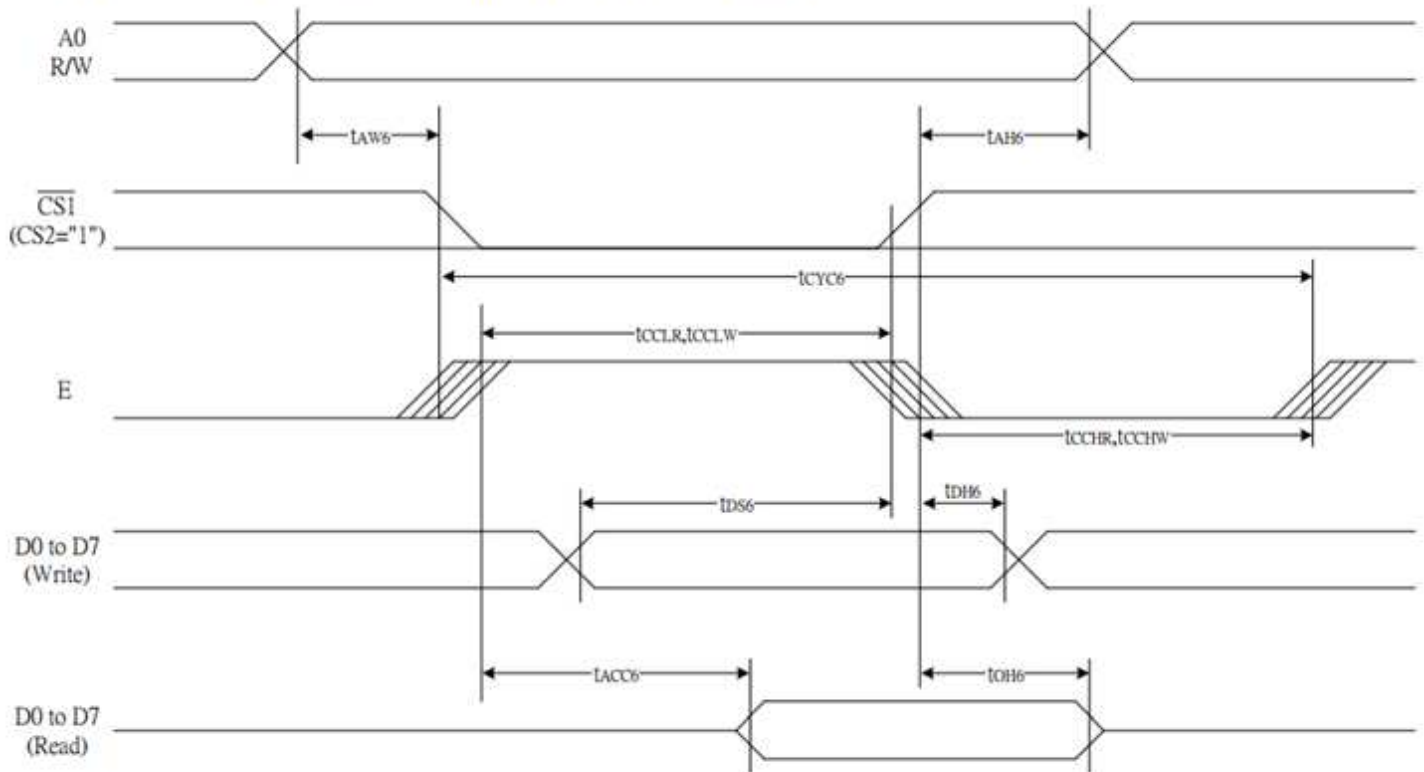

Item	Signal	Symbol	Condition	Rating		Units
				Min.	Max.	
Address hold time	A0	t_{AH6}		0	—	ns
Address setup time		t_{AW6}		0	—	
System cycle time		t_{CYC6}		240	—	
Enable L pulse width (WRITE)	WR	t_{EWLW}		80	—	
Enable H pulse width (WRITE)		t_{EWHW}		80	—	
Enable L pulse width (READ)	RD	t_{EWLR}		80	—	
Enable H pulse width (READ)		t_{EWHR}		140	—	
WRITE Data setup time	D0 to D7	t_{DS6}		40	—	
WRITE Address hold time		t_{DH6}		10	—	
READ access time		t_{ACC6}	$C_L = 100 \text{ pF}$	—	70	
READ Output disable time		t_{OH6}	$C_L = 100 \text{ pF}$	5	50	

Example Initialization Program

```
/******NHD-C24064WO******/
void init()
{
    command_master(0xA2);           //1/9 bias
    command_master(0xA0);           //ADC segment driver direction (A0=Normal)
    command_master(0xC8);           //Com output reverse
    command_master(0xA4);           //Display all points normal
    command_master(0x40);           //Display Start line set
    command_master(0x25);           //Internal resistor ratio
    command_master(0x81);           //Electronic volume mode set
    command_master(0x10);           //Electronic Volume
    command_master(0x2F);           //Power controller set
    command_master(0xAF);           //Display on

    command_slave(0xA2);            //1/9 bias
    command_slave(0xA0);            //ADC segment driver direction (A0=Normal)
    command_slave(0xC8);            //Com output reverse
    command_slave(0xA4);            //Display all points normal
    command_slave(0x40);            //Display Start line set
    command_slave(0x25);            //Internal resistor ratio
    command_slave(0x81);            //Electronic volume mode set
    command_slave(0x10);            //Electronic Volume
    command_slave(0x2F);            //Power controller set
    command_slave(0xAF);            //Display on
}

/*******/
void command_master(unsigned int c)
{
    CS_Master = reset;
    AO = reset;                       //Command   LOW
    WRT = reset;
    P1 = c;
    delay(1);
    WRT = set;
    CS_Master = set;
}

/*******/
void data_master(unsigned int d)
{
    CS_Master = reset;
    AO = set;                           //Data     High
    delay(1);
    WRT = reset;
    P1 = d;
    delay(1);
    WRT = set;
    CS_Master = set;
}

/*******/
void commmand_slave(unsigned int c)
{
    CS_Slave = reset;
    AO = reset;                       //Command   LOW
```

```
WRT = reset;
P1 = c;
delay(1);
WRT = set;
CS_Slave = set;
}

/*****/

void data_slave(unsigned int d)
{
    CS_Slave = reset;
    AO = set;           //Data      High
    delay(1);
    WRT = reset;
    P1 = d;
    delay(1);
    WRT = set;
    CS_Slave = set;
}

/*****/
```

Quality Information

Test Item	Content of Test	Test Condition	Note
High Temperature storage	Endurance test applying the high storage temperature for a long time.	+80°C , 48hrs	2
Low Temperature storage	Endurance test applying the low storage temperature for a long time.	-30°C , 48hrs	1,2
High Temperature Operation	Endurance test applying the electric stress (voltage & current) and the high thermal stress for a long time.	+70°C 48hrs	2
Low Temperature Operation	Endurance test applying the electric stress (voltage & current) and the low thermal stress for a long time.	-20°C , 48hrs	1,2
High Temperature / Humidity Operation	Endurance test applying the electric stress (voltage & current) and the high thermal with high humidity stress for a long time.	+40°C , 90% RH , 48hrs	1,2
Thermal Shock resistance	Endurance test applying the electric stress (voltage & current) during a cycle of low and high thermal stress.	-0°C,30min -> 25°C,5min -> 50°C,30min = 1 cycle 10 cycles	
Vibration test	Endurance test applying vibration to simulate transportation and use.	10-55Hz , 15mm amplitude. 60 sec in each of 3 directions X,Y,Z For 15 minutes	3
Static electricity test	Endurance test applying electric static discharge.	VS=800V, RS=1.5kΩ, CS=100pF One time	

Note 1: No condensation to be observed.

Note 2: Conducted after 4 hours of storage at 25°C, 0%RH.

Note 3: Test performed on product itself, not inside a container.

Precautions for using LCDs/LCMs

See Precautions at www.newhavendisplay.com/specs/precautions.pdf

Warranty Information and Terms & Conditions

http://www.newhavendisplay.com/index.php?main_page=terms