



Chipsmall Limited consists of a professional team with an average of over 10 year of expertise in the distribution of electronic components. Based in Hongkong, we have already established firm and mutual-benefit business relationships with customers from,Europe,America and south Asia,supplying obsolete and hard-to-find components to meet their specific needs.

With the principle of "Quality Parts,Customers Priority,Honest Operation,and Considerate Service",our business mainly focus on the distribution of electronic components. Line cards we deal with include Microchip,ALPS,ROHM,Xilinx,Pulse,ON,Everlight and Freescale. Main products comprise IC,Modules,Potentiometer,IC Socket,Relay,Connector.Our parts cover such applications as commercial,industrial, and automotives areas.

We are looking forward to setting up business relationship with you and hope to provide you with the best service and solution. Let us make a better world for our industry!



## Contact us

Tel: +86-755-8981 8866 Fax: +86-755-8427 6832

Email & Skype: info@chipsmall.com Web: www.chipsmall.com

Address: A1208, Overseas Decoration Building, #122 Zhenhua RD., Futian, Shenzhen, China





## User's Guide

# NHD-TS-12864CRNA#

**TOUCH PANEL**

---

Tel: (847) 844-8795 Fax: (847) 844-8796

**Newhaven Display International**  
**2511 Technology Drive, #101**  
**Elgin, IL 60124**

*May 28, 2009*

**RECORDS OF REVISION**

**DOC. FIRST ISSUE**

VERSION	DATE	REVISED PAGE NO.	<b>SUMMARY</b>
0	2007/8/9		First issue

# 1. General Specification

ITEM	STANDARD VALUE	UNIT
Outline dimension	71.35±0.3(L) x55.00±0.3(W) x1.1±0.1(T)	mm
View area	61.60 (L) x47.20 (W)	mm
Active area	59.00 (L) x 44.20(W)	mm

# 2. Absolute Maximum Ratings

ITEM	SYMBOL	MIN.	TYP.	MAX.	UNIT
Operating Temperature	T <sub>OP</sub>	0	—	+50	°C
Storage Temperature	T <sub>ST</sub>	-20	—	+70	°C
Operating temperature		20		85	%RH
Storage temperature		10		90	%RH
Light transmission			80		%

# 3. Reliability

## ■ Content of Reliability Test

Environmental Test			
Test Item	Content of Test	Test Condition	Applicable Standard
High Temperature storage	Endurance test applying the high storage temperature and operating test .	70°C 120hrs	—
Low Temperature storage	Endurance test applying the high storage temperature for a long time.	-20°C 120hrs	—

\*\*\*The test of above being finished, touch screen must satisfy the specification as below:

Resistance between leads :

- (1) Film : 570~920 Ohm , Glass: 220 ~ 330 Ohm
- (2) Linearity : Less than 1.5%
- (3) Insulation resistance: 10M Ohm or more.

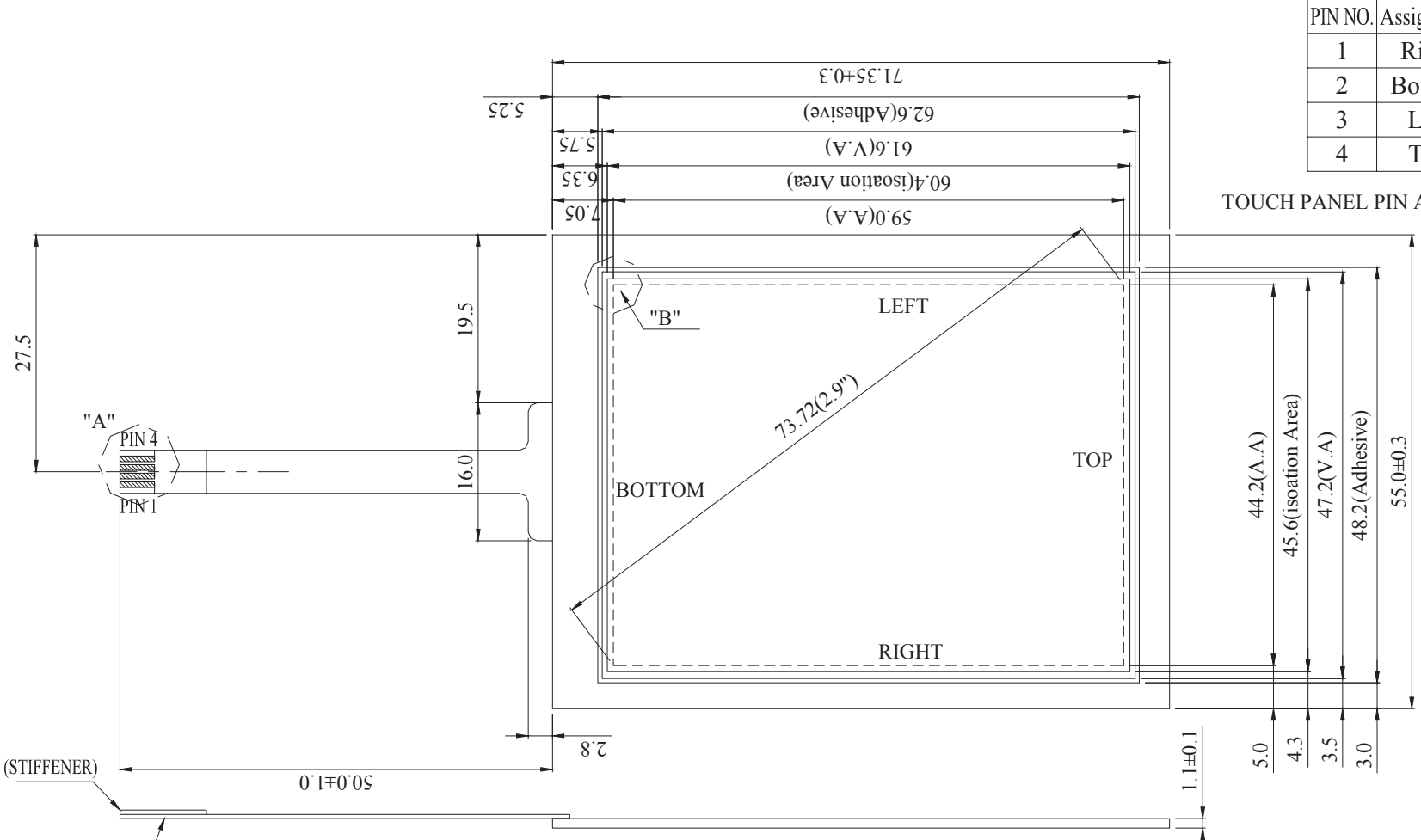

PIN NO.	Assignment
1	Right
2	Bottom
3	Left
4	Top

TOUCH PANEL PIN ASSIGNMENT

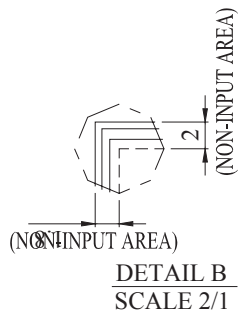
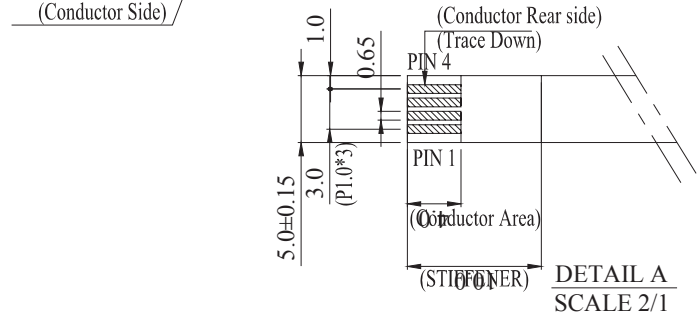

The non-specified tolerance of dimension is ±0.3mm.

SCALE:	3/2	UNIT:	mm	Newhaven Display
REV:	0	PAGE:	1/1	
APPROVE		MODEL NHD-TS-12864CRNA#		
CHECK		TITLE T.P DRAWING		
DRAW		DWG NO.		

## LCD Panel Estimate Feedback Sheet

Panel Item Number : \_\_\_\_\_

### **1、Panel Specification :**

1. Panel Type :  Pass  NG , \_\_\_\_\_
2. View Direction :  Pass  NG , \_\_\_\_\_
3. Numbers of Dots(Icon) :  Pass  NG , \_\_\_\_\_
4. Operating Temperature :  Pass  NG , \_\_\_\_\_
5. Storage Temperature :  Pass  NG , \_\_\_\_\_
6. Others : \_\_\_\_\_

### **2、Mechanical Specification :**

1. Dots(Icon) Size :  Pass  NG , \_\_\_\_\_
2. VA Size :  Pass  NG , \_\_\_\_\_
3. AA Size :  Pass  NG , \_\_\_\_\_
4. Outline Dimension :  Pass  NG , \_\_\_\_\_
5. Others :  Pass  NG , \_\_\_\_\_

### **3、Summary :**

Sales signature : \_\_\_\_\_

Customer Signature : \_\_\_\_\_

Date :    /    /    \_\_\_\_\_