



Chipsmall Limited consists of a professional team with an average of over 10 year of expertise in the distribution of electronic components. Based in Hongkong, we have already established firm and mutual-benefit business relationships with customers from,Europe,America and south Asia,supplying obsolete and hard-to-find components to meet their specific needs.

With the principle of “Quality Parts,Customers Priority,Honest Operation,and Considerate Service”,our business mainly focus on the distribution of electronic components. Line cards we deal with include Microchip,ALPS,ROHM,Xilinx,Pulse,ON,Everlight and Freescale. Main products comprise IC,Modules,Potentiometer,IC Socket,Relay,Connector.Our parts cover such applications as commercial,industrial, and automotives areas.

We are looking forward to setting up business relationship with you and hope to provide you with the best service and solution. Let us make a better world for our industry!



Contact us

Tel: +86-755-8981 8866 Fax: +86-755-8427 6832

Email & Skype: info@chipsmall.com Web: www.chipsmall.com

Address: A1208, Overseas Decoration Building, #122 Zhenhua RD., Futian, Shenzhen, China



RF Modulator for UHF Band

DESCRIPTION

The NJM2259 is a RF modulator IC especially designed for UHF band RF modulator and consists of video clamp circuit, white clip circuit, video AM modulator and audio FM modulator, built into one chip.

PACKAGE OUTLINE

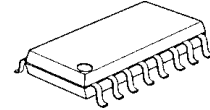

NJM2259M

FEATURES

- Operating Voltage 5V
- Picture-to-sound ratio is adjustable
- Audio ripple is decreased by two internal regulators
- Audio input circuit with low shock noise
- Carrier-off switch function on chip
- Bipolar Technology
- Package Outline : DMP16

BLOCK DIAGRAM

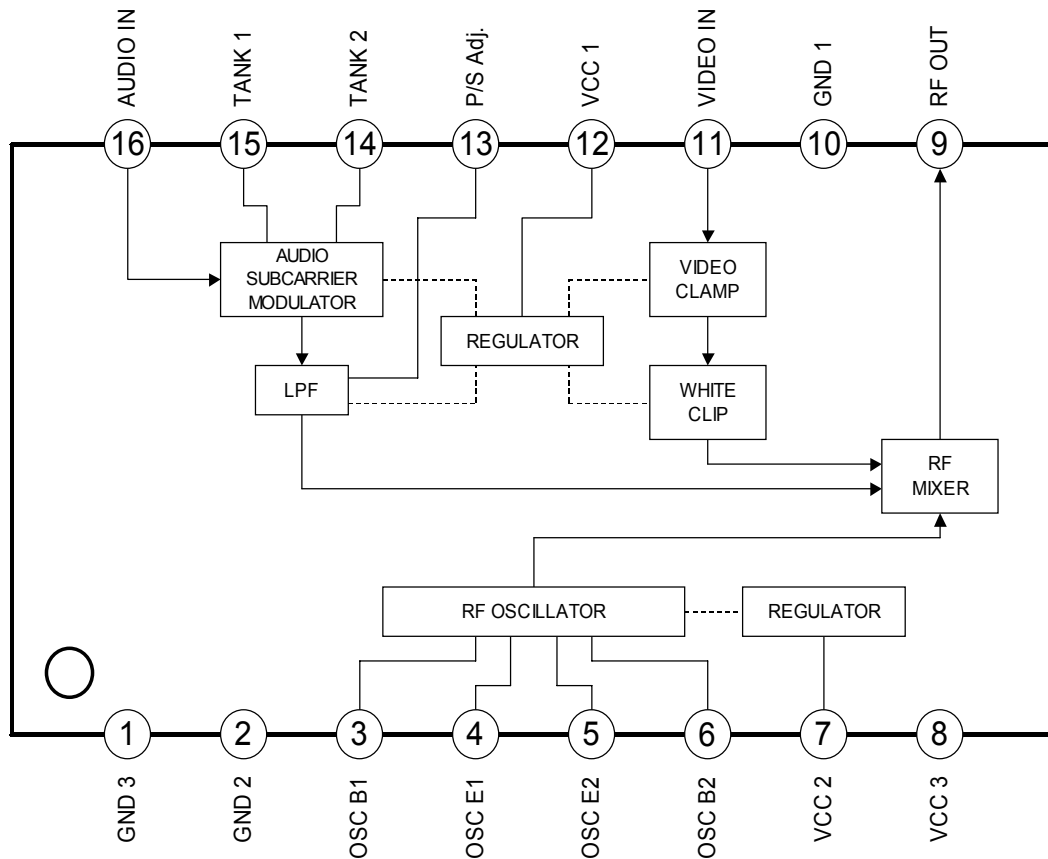

■ ABSOLUTE MAXIMUM RATINGS

($T_A=25^{\circ}\text{C}$)

Parameter	Symbol	Ratings	Unit
Supply Voltage	V_{CC}	7	V
Power Dissipation	P_D	300	mW
Input Voltage	V_I	-0.3 to V_{CC}	V
Operating Temperature Range	T_{opr}	-20 to +75	$^{\circ}\text{C}$
Storage Temperature Range	T_{stg}	-40 to +125	$^{\circ}\text{C}$

■ RECOMMENDED OPERATING VOLTAGE RANGE

($T_A=25^{\circ}\text{C}$)

Parameter	Condition	Symbol	Min.	Typ.	Max.	Unit
Operating Voltage		V_{CC}	4.5	5.0	5.5	V

■ ELECTRICAL CHARACTERISTICS

($V_{CC}=5\text{V}, T_A=25^{\circ}\text{C}$)

Parameter	Condition	Symbol	Min.	Typ.	Max.	Unit
Operating Current	No video/audio input signal	I_{CC}	18	30	32	mA
Video Output Level (Note 1)	Video input Signal (Pin11)= $0.5V_{PP}$	V_O	(73)	78	(83)	dBu
Video Modulation Depth (Note 1)	Video input Signal (Pin11)= $0.5V_{PP}$	mp	(60)	75	(90)	%
Video Limiter Modulation Depth (Note 1)	Video input Signal (Pin11)= $0.5V_{PP}$	mpmax	(80)	94	(98)	%
Differential Gain	Video input signal (Pin11)= $0.5V_{PP}$ Staircase	DG	-	± 3	-	%
Differential Phase	Video input Signal (Pin11)= $0.5V_{PP}$ Staircase	DP	-	± 3	-	deg
Picture-to-sound Ratio (Note 1)	Video input Signal (Pin11)= $0.5V_{PP}$	PS	(10)	13	(16)	dB
Sound FM Modulation Depth (Note 1)	Audio input Signal (Pin16)= 70mV_{PP} 100%= $\pm 50\text{kHz}$ dev.	ms	(85)	100	(115)	%
Audio Distortion	ms=100%, 1kHz sine wave	THD	-	0.3	-	%
Audio Signal-to-noise Ratio	ms=100%, 1kHz sine wave Video input Signal (Pin11)= $1V_{PP}$	ASN	-	60	-	dB
Maximum Sound FM Modulation	Audio input Signal (Pin16)= 500mV_{PP} 1kHz sine wave	msmax	-	700	-	%

(Note 1) Because AC characteristics largely depends on application circuit, DC test is applied these parameters.

■ TEST CIRCUIT

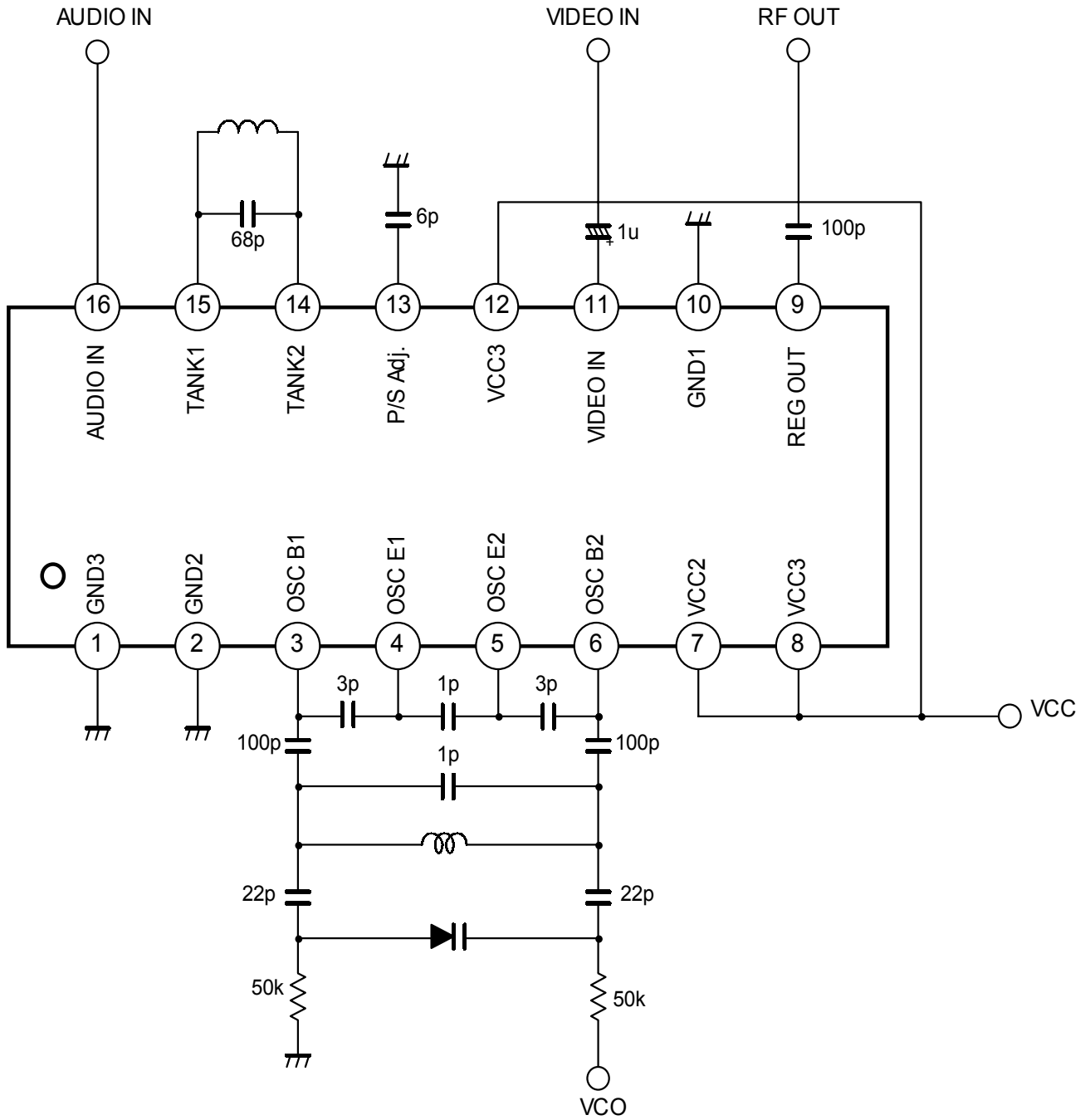

■ TERMINAL CHARACTERISTICS

No.	Symbol	Typ. DC Voltage (V)	Equivalent Circuit	Function
1	GND 3	-		GND for RF OSC AMP
2	GND 2	-		GND for RF OSC
3 4 5 6	OSC B1 OSC E1 OSC E2 OSC B2	2.55 1.75 1.75 2.55		RF Oscillator
7	VCC 2	-		RF OSC Regulator Power Supply
8	VCC 3	-		RF Mixer Power Supply
9	RF OUT	3.95		RF Mixer Output
10	GND 1	-		GND Terminal except for RF Oscillator
11	VIDEO IN	1.70		Video Signal Input

No.	Symbol	Typ. DC Voltage (V)	Equivalent Circuit	Function
12	VCC 1	-		Power Supply
13	P/S Adj.	3.55 TANK 1: H		Picture-to-sound Ratio Adjust
		2.80 TANK 1: L		Sound FM Modulation Circuit
14	TANK 2	H : 3.60 L : 2.85		
15	TANK 1	H : 3.60 L : 2.85		
16	AUDIO IN	-		Audio Signal Input

■ TYPICAL CHARACTERISTICS

$T_A=25^\circ\text{C}$

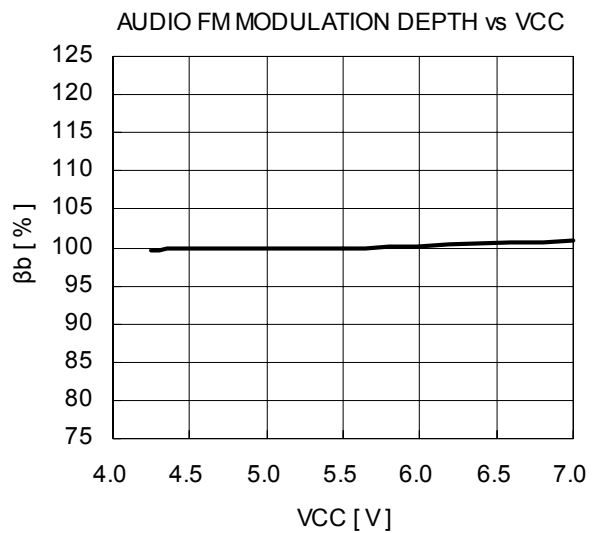
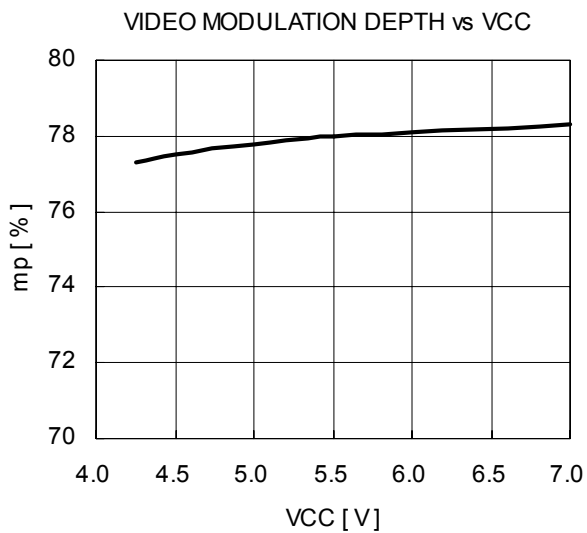
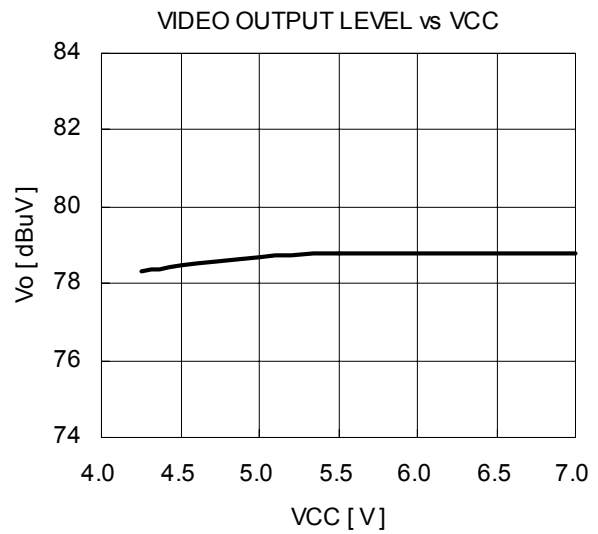
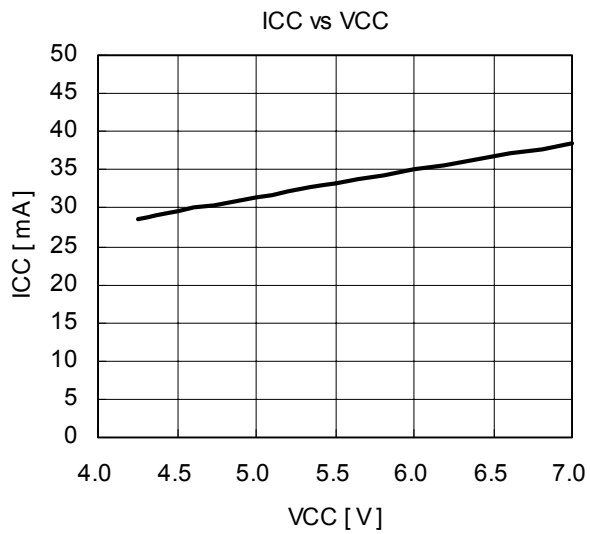

■ OUTLINE DRAWING

DMP16

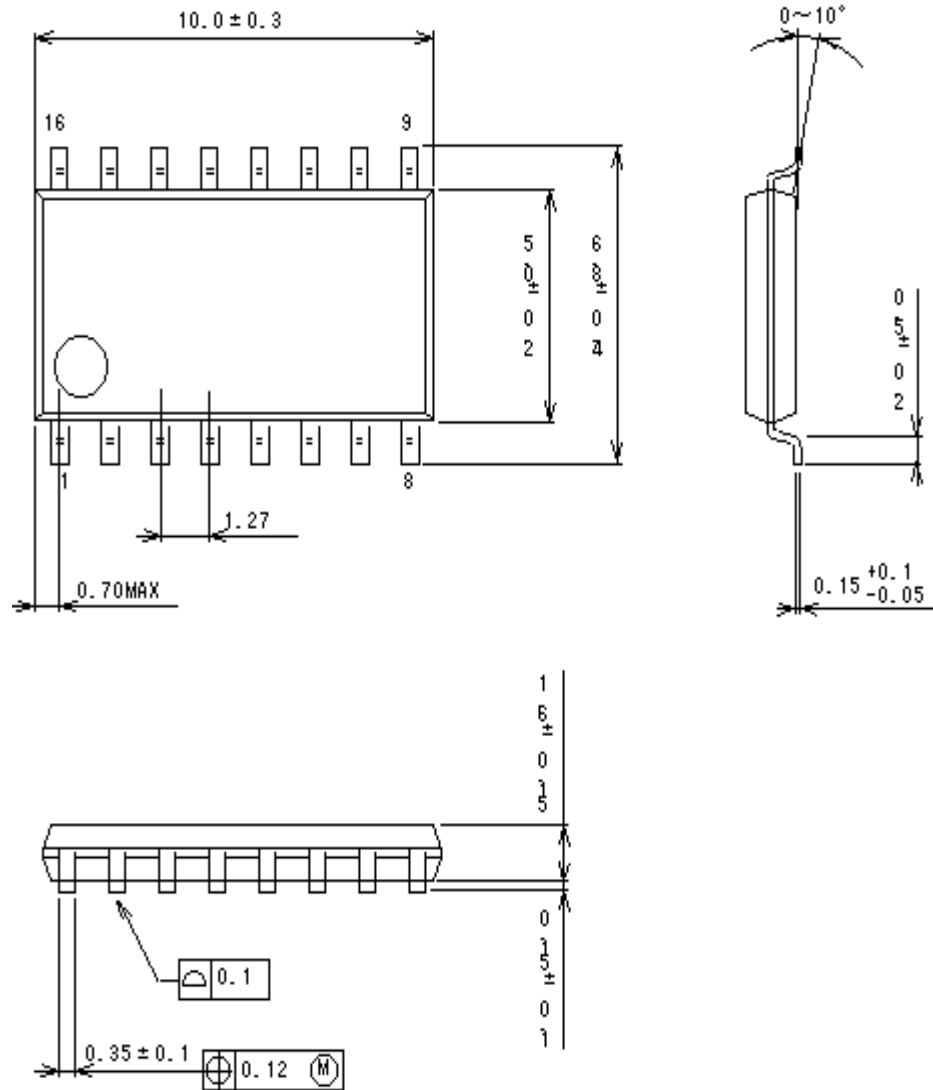

[CAUTION]

The specifications on this databook are only given for information, without any guarantee as regards either mistakes or omissions. The application circuits in this databook are described only to show representative usages of the product and not intended for the guarantee or permission of any right including the industrial rights.