



Chipsmall Limited consists of a professional team with an average of over 10 year of expertise in the distribution of electronic components. Based in Hongkong, we have already established firm and mutual-benefit business relationships with customers from,Europe,America and south Asia,supplying obsolete and hard-to-find components to meet their specific needs.

With the principle of "Quality Parts,Customers Priority,Honest Operation,and Considerate Service",our business mainly focus on the distribution of electronic components. Line cards we deal with include Microchip,ALPS,ROHM,Xilinx,Pulse,ON,Everlight and Freescale. Main products comprise IC,Modules,Potentiometer,IC Socket,Relay,Connector.Our parts cover such applications as commercial,industrial, and automotives areas.

We are looking forward to setting up business relationship with you and hope to provide you with the best service and solution. Let us make a better world for our industry!



Contact us

Tel: +86-755-8981 8866 Fax: +86-755-8427 6832

Email & Skype: info@chipsmall.com Web: www.chipsmall.com

Address: A1208, Overseas Decoration Building, #122 Zhenhua RD., Futian, Shenzhen, China



75Ω Driver with Filer and Y/C MIX

■ GENERAL DESCRIPTION

NJM2570 is a video amplifier included LPF in Y and C system. Adjustable LPF characteristic with external resistor and output with 75ohm driver optimize the TV monitor system.

Also, it can discriminated the aspect ratio of TV by internal DC interface for S terminal.

NJM2570 includes power save circuit to suitable for portable video application.

■ PACKAGE OUTLINE



NJM2570V

■ FEATURES

- Operating Voltage 4.5 to 5.5V
- Input Y and C 0.5Vpp
- Internal LPF
 - 0dBtyp. at 4MHz (at IREF=33kΩ)
 - 35dBtyp. at 10MHz (at IREF=33kΩ)
 - 0dBtyp. at 6MHz (at IREF=22kΩ)
 - 40dBtyp. at 16MHz (at IREF=22kΩ)
- Internal DC Interface for aspect ratio discrimination
- Bipolar technology
- Package Outline SSOP16

■ PIN CONFIGURATION

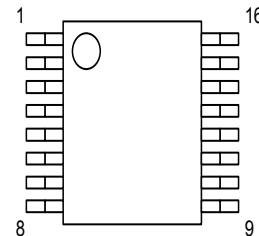

1. Cin
2. GND
3. SDCin
4. SDCout
5. Cout
6. Vout
7. Vsag
8. GND2
9. V+2
10. Ysag
11. Yout
12. VREF
13. POWERSAVE
14. Yin
15. V+1
16. IREF

■ BLOCK DIAGRAM

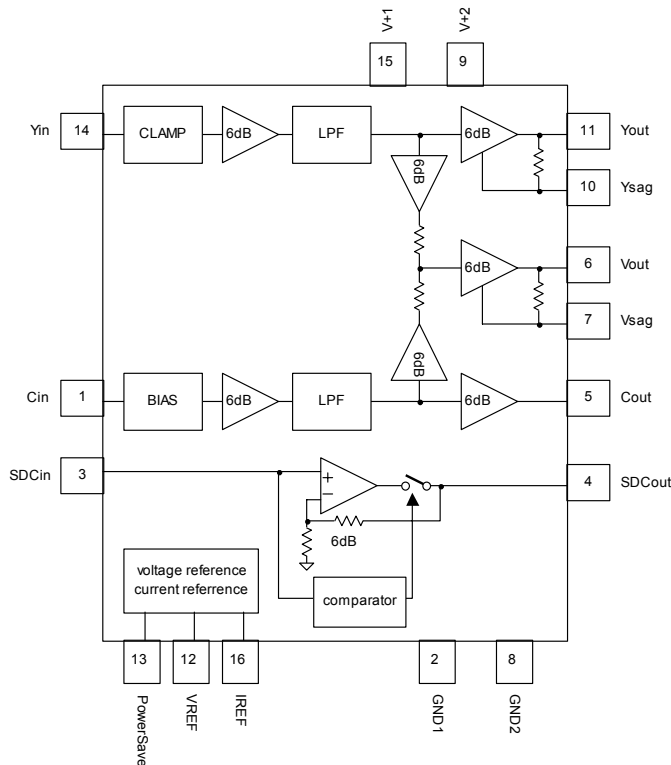

■ ABSOLUTE MAXIMUM RATINGS(Ta=25°C)

PARAMETER	SYMBOL	RATINGS	UNIT
Supply Voltage	V ⁺	7.0	V
Power Dissipation	P _D	300	mW
Operating Temperature Range	Topr	-40 to +85	°C
Storage Temperature Range	Tstg	-40 to +125	°C

■ RECOMMENDED OPEARATING CONDITION(Ta=25°C)

PARAMETER	SYMBOL	RATINGS	MIN.	TYP.	MAX.	UNIT
Operating Voltage 1	Vopr1	V ⁺ 1	4.5	5.0	5.5	V
Operating Voltage 2	Vopr2	V ⁺ 2	4.5	5.0	5.5	V

■ ELECTRICAL CHARACTERISTICS(V⁺1=V⁺2=5.0V,R_L=150Ω,Ta=25°C, IREF=22kΩ at non-designation)

PARAMETER	SYMBOL	TEST CONDITION	MIN.	TYP.	MAX.	UNIT
Operating Circuit 1	I _{CC1}	V ⁺ 1=5.0V, No signal	-	10	18	mA
Operating Circuit 2	I _{CC2}	V ⁺ 2=5.0V, No signal	-	15	25	mA
Operating Circuit 1 at Power Save	I _{save1}	V ⁺ 1=5.0V, Power Save Mode	-	50	120	μA
Operating Circuit 2 at Power Save	I _{save2}	V ⁺ 2=5.0V, Power Save Mode	-	0	120	μA
Voltage Gain 1(Y Signal)	G _{vy}	Yin=100kHz,0.5Vpp Input Sign signal	12.0	12.4	12.9	dB
Voltage Gain 1(C Signal)	G _{vc}	Cin=4.43MHz,0.15Vpp Input Sign signal	12.0	12.4	12.9	dB
Voltage Gain 1(V Signal)	G _{vv}	Yin=100kHz,0.5Vpp Input Sign signal	12.0	12.4	12.9	dB
Frequency Characteristics (Y Signal)	G _{fy1-1}	Yin=4MHz/100kHz, 0.5Vpp, Input Sine signal IREF=33kΩ	-3.0	0	1.0	dB
	G _{fy1-2}	Yin=10MHz/100kHz, 0.5Vpp, Input Sign signal IREF=33kΩ	-	-35	-30	
	G _{fy2-1}	Yin=6MHz/100kHz, 0.5Vpp, Input Sine signal IREF=22kΩ	-3.0	0	2.0	
	G _{fy2-2}	Yin=16MHz/100kHz, 0.5Vpp Input Sine signal, IREF=22kΩ	-	-40	-30	
Frequency Characteristics (C Signal)	G _{fc1-1}	Cin=4.43MHz-500kHz, 0.15Vpp Input Sine signal, IREF=33kΩ	-1.0	1.0	3.0	dB
	G _{fc1-2}	Cin=4.43MHz+500kHz, 0.15Vpp Input Sine signal, IREF=33kΩ	-5.0	-2.0	1.0	
	G _{fc2-1}	Cin=4.43MHz-500kHz, 0.15Vpp Input Sine signal, IREF=22kΩ	-1.0	0	1.0	
	G _{fc2-2}	Cin=4.43MHz+500kHz, 0.15Vpp Input Sine signal, IREF=22kΩ	-1.0	0	1.0	
Maximum Output Voltage Swing 1(Y Signal)	V _{oym}	V ⁺ 1=V ⁺ 2=4.5V,Yin=100kHz, Sine Signal, THD=1%, R _L =75Ω	1.2	1.5	-	V _{p-p}
Maximum Output Voltage Swing 1(C Signal)	V _{ocm}	V ⁺ 1=V ⁺ 2=4.5V,Cin=4.43MHz, Sine Signal, THD=1%, R _L =75Ω	1.05	1.85	-	V _{p-p}
Maximum Output Voltage Swing 1(V Signal)	V _{ovm}	V ⁺ 1=V ⁺ 2=4.5V,Yin=100kHz, Sine Signal, THD=1%, R _L =75Ω	1.2	1.4	-	V _{p-p}
SW Change Voltage High Level for Power Save	V _{cH}	Active	1.8	-	V ⁺	V
SW Change Voltage High Level for Power Save	V _{cL}	Non-active	0	-	0.3	

PRELIMINARY

■ ELECTRICAL CHARACTERISTICS ($V^+1=V^+2=5.0V, R_L=150\Omega, T_a=25^\circ C, I_{REF}=22k\Omega$ at non-designation)

PARAMETER	SYMBOL	TEST CONDITION	MIN.	TYP.	MAX.	UNIT
Crosstalk 1(Yin to Cout)	CTyc	Yin to Cout=20log(Cout/Yout) Yin=4.43MHz,0.5Vpp Sine Signal, Cin=AC GND	-	-50	-40	dB
Crosstalk 2(Cin to Yout)	CTcy	Cin to Yout=20log(Yout/Cout) Cin=4.43MHz,0.15Vpp Sine Signal, Yin=AC GND	-	-60	-40	dB
S/N1(Y Signal)	SNy	Yin=50% White Video Signal, $R_L=75\Omega$ at Yout Bandwidth 100kHz to 6MHz	55	60	-	dB
S/N2(C Signal)	SNc	Cin=100% Red Field Video Signal, $R_L=75\Omega$ at Yout Bandwidth 100Hz to 500kHz	55	60	-	dB
S/N3(V Signal)	SNv	Yin=50% White Video Signal, $R_L=75\Omega$ at Yout at Vout Bandwidth 100kHz to 6MHz	53	57	-	dB
2nd. Distortion 1(Y Signal)	Hy	Yin=1MHz,0.5Vpp, Sine Signal	-	-50	-40	dB
2nd. Distortion 1(C Signal)	Hc	Cin=4.43MHz,0.15Vpp, Sine Signal	-	-50	-40	dB
2nd. Distortion 1(V Signal)	Hv	Yin=1MHz,0.5Vpp, Sine Signal	-	-50	-40	dB
SDC Voltage Gain	G_v SDC	SDCin=1.0V, $R_L=100k\Omega$	5.5	6.0	6.5	dB
SDC Maxim Output Voltage	V_{om} SDC	$R_L=100k\Omega, V^+1=V^+2=4.5V$	3.6	-	-	V
Threshold Voltage for SDC Output Impedance	V_{thR} SDC	Change Guarantee for SDC High Impedance	-	-	0.3	V
SDC Output Impedance	RSDC	SDCout at High Impedance	165	220	275	$k\Omega$

■ CONTROL TERMINAL

PARAMETER	CONTROL	NOTES
Power Save	H	Power Save: OFF
	L	Power Save: ON
	OPEN	Power Save: ON

TEST CIRCUIT

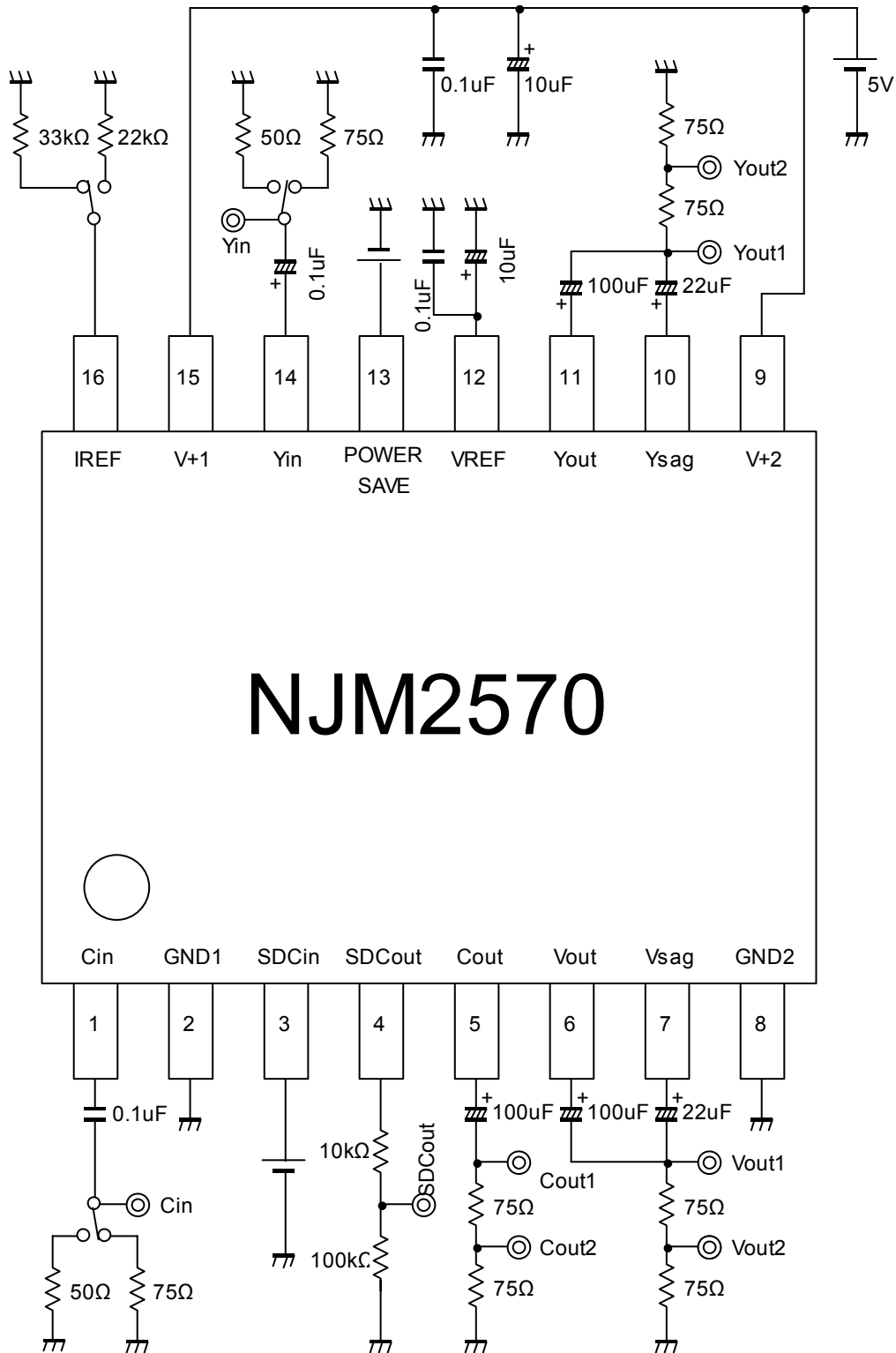

■ TERMINAL EXPLANATION

PIN No.	SYMBOL	EQUIVALENT CIRCUIT	DC VOLTAGE	NOTE
1	Cin			
2	GND			
3	SDCin			
4	SDCout			

■ TERMINAL EXPLANATION

PIN No.	SYMBOL	EQUIVALENT CIRCUIT	DC VOLTAGE	NOTE
5	Cout			
6	Vout			
7	Vsag			
8	GND2			

■ TERMINAL EXPLANATION

PIN No.	SYMBOL	EQUIVALENT CIRCUIT	DC VOLTAGE	NOTE
9	V ⁺ 2			
10	Ysag			
11	Yout			
12	Vref			

■ TERMINAL EXPLANATION

PIN No.	SYMBOL	EQUIVALENT CIRCUIT	DC VOLTAGE	NOTE
13	Power Save			
14	Yin			
15	V ⁺ 1			
16	Iref			

[CAUTION]

The specifications on this databook are only given for information , without any guarantee as regards either mistakes or omissions. The application circuits in this databook are described only to show representative usages of the product and not intended for the guarantee or permission of any right