



Chipsmall Limited consists of a professional team with an average of over 10 year of expertise in the distribution of electronic components. Based in Hongkong, we have already established firm and mutual-benefit business relationships with customers from,Europe,America and south Asia,supplying obsolete and hard-to-find components to meet their specific needs.

With the principle of “Quality Parts,Customers Priority,Honest Operation,and Considerate Service”,our business mainly focus on the distribution of electronic components. Line cards we deal with include Microchip,ALPS,ROHM,Xilinx,Pulse,ON,Everlight and Freescale. Main products comprise IC,Modules,Potentiometer,IC Socket,Relay,Connector.Our parts cover such applications as commercial,industrial, and automotives areas.

We are looking forward to setting up business relationship with you and hope to provide you with the best service and solution. Let us make a better world for our industry!



## Contact us

Tel: +86-755-8981 8866 Fax: +86-755-8427 6832

Email & Skype: info@chipsmall.com Web: www.chipsmall.com

Address: A1208, Overseas Decoration Building, #122 Zhenhua RD., Futian, Shenzhen, China



## 4-Input / 1-Output Stereo Audio Selector

### ■ GENERAL DESCRIPTION

The **NJM2755** is 4 Input / 1 Output Stereo Audio Selector.

The **NJM2755** consists of switches and buffer operational amplifiers.

Based on the internal switch op-amp technology, the **NJM2755** features lower output noise, lower distortion and higher channel separation than the general Multiplexers or Analogue Switches.

The **NJM2755** contains compatibility with NJM2752(2in-1out SW), NJM2753(3in-1out SW).

### ■ PACKAGE OUTLINE

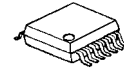

**NJM2755V**

### ■ APPLICATIONS

- LCD-TV/PDP-TV
- Car Stereo
- Any Audio System

### ■ FEATURES

- Operating Voltage 4.7 to 10V
- 4 Input / 1 Output Stereo Audio Selectors
- Low Output Noise -114dBV typ.
- Low Distortion 0.0009% typ.
- Bipolar Technology
- Package Outline SSOP16

### ■ BLOCK DIAGRAM

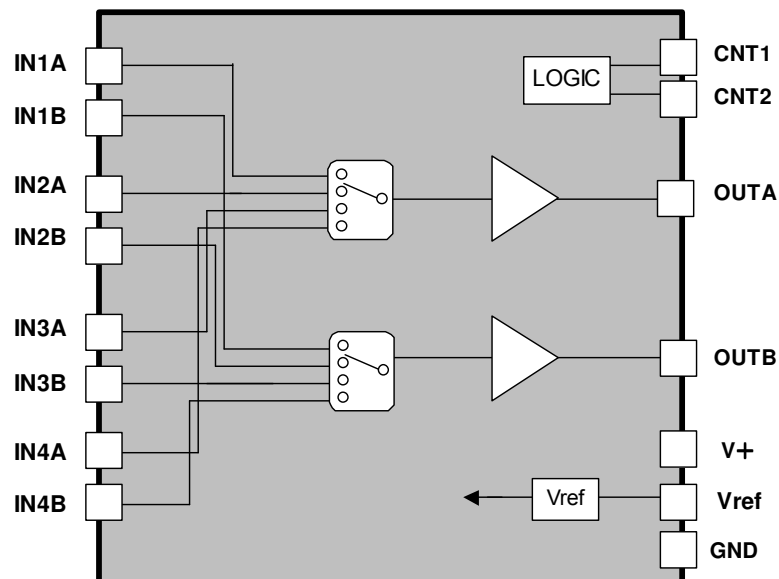

# NJM2755

■ PIN CONFIGURATIONS  
NJM2755 SSOP16

## SSOP16

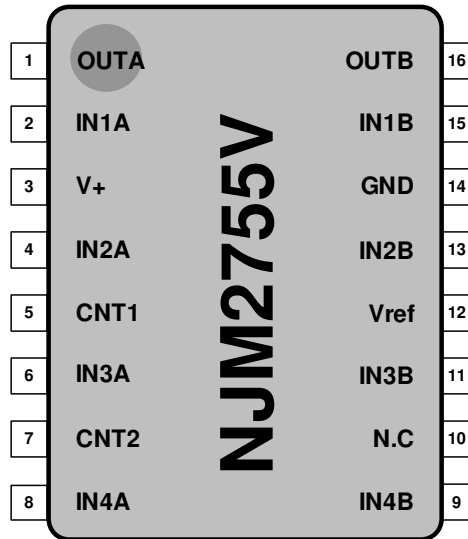

PIN.No.	SYMBOL	FUNCTION	PIN.No.	SYMBOL	FUNCTION
1	OUTA	Ach Output Terminal	9	IN4B	Bch Input Terminal4
2	IN1A	Ach Input Terminal1	10	N.C	No Connection
3	V+	Power Supply Terminal	11	IN3B	Bch Input Terminal3
4	IN2A	Ach Input Terminal2	12	Vref	Reference Terminal
5	CNT1	Control Switch Terminal1	13	IN2B	Bch Input Terminal2
6	IN3A	Ach Input Terminal3	14	GND	GND Terminal
7	CNT2	Control Switch Terminal2	15	IN1B	Bch Input Terminal1
8	IN4A	Ach Input Terminal4	16	OUTB	Bch Output Terminal

**[Reference]**

The NJM2755 contains compatibility with NJM2752 (2in-1out SW), NJM2753 (3in-1out SW).

### NJM2752

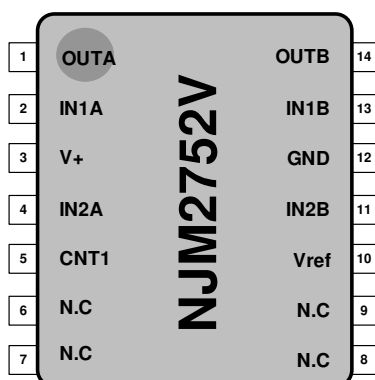

### NJM2753

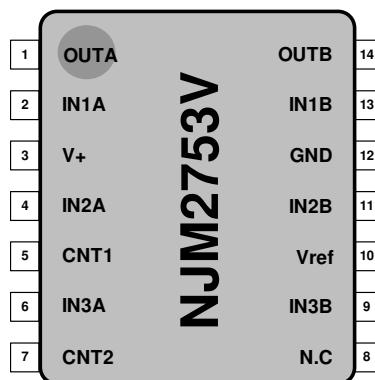

## ■ ABSOLUTE MAXIMUM RATINGS (Ta=25°C)

PARAMETER	SYMBOL	RATING	UNIT
Supply Voltage	V <sup>+</sup>	12	V
Power Dissipation	P <sub>D</sub>	SSOP16 490 <sup>1)</sup> 630 <sup>2)</sup> <small>NOTE 1): EIA/JEDEC STANDARD Test board (76.2x114.3x1.6mm, 2layer, FR-4) mounting 2): EIA/JEDEC STANDARD Test board (76.2x114.3x1.6mm, 4layer, FR-4) mounting</small>	mW
Operating Temperature Range	T <sub>OPR</sub>	-40 to +85	°C
Storage Temperature Range	T <sub>STR</sub>	-40 to +150	°C

## ■ ELECTRICAL CHARACTERISTICS ( Ta=25°C, V<sup>+</sup>=9V)

PARAMETER	SYMBOL	TEST CONDITION	MIN.	TYP.	MAX.	UNIT
Operating Voltage	V <sup>+</sup>		4.7	9.0	10	V
Supply Current	I <sub>CC</sub>	No Signal	-	10	15	mA
Reference Voltage	V <sub>REF</sub>		-	4.5	-	V
Voltage Gain	G <sub>V</sub>	Vin=1Vrms, f=1kHz	-1	0	1	dB
Total Harmonic Distortion	THD+N	Vin=1Vrms, f=1kHz	-	0.0009	0.03	%
Output Noise Voltage	V <sub>NO</sub>	A-Weighted	-	-114 (2)	-100 (10)	dBV (μVrms)
Maximum Output Voltage	V <sub>OM</sub>	f=1kHz, THD=1%	6 (2.0)	8 (2.5)	-	dBV (Vrms)
Cross Talk	CT	Vin=1Vrms, f=1kHz, A-Weighted	85	100	-	dB
Channel Separation	CS	Vin=1Vrms, f=1kHz, A-Weighted	90	110	-	dB
Switch-ON Voltage Level	V <sub>CH</sub>		2.4	-	-	V
Switch-OFF Voltage Level	V <sub>CL</sub>		-	-	0.5	V
Input Impedance	R <sub>IN</sub>		-	100	-	kΩ
Output Impedance	R <sub>OUT</sub>		-	45	-	Ω

## ■ SWITCH CONTROL LOGIC

CNT2	CNT1	INPUT SELECTOR Ach / Bch
L	L	1
L	H	2
H	L	3
H	H	4

## ■ TERMINAL DESCRIPTION

PIN No.	SYMBOL	FUNCTION	EQUIVALENT CIRCUIT	TERMINAL VOLTAGE
2 4 6 8 9 11 13 15	IN1A IN2A IN3A IN4A IN4B IN3B IN2B IN1B	Ach Input Terminal1 Ach Input Terminal2 Ach Input Terminal3 Ach Input Terminal4 Bch Input Terminal4 Bch Input Terminal3 Bch Input Terminal2 Bch Input Terminal1		V+/2
5 7	CNT1 CNT2	Control Switch Terminal1 Control Switch Terminal2		0V (GND)
1 16	OUTA OUTB	Ach Output Terminal Bch Output Terminal		V+/2
12	Vref	Reference Terminal		V+/2
3 14	V+ GND	Power Supply Terminal GND Terminal		V+ 0V

## MEASUREMENT CIRCUIT

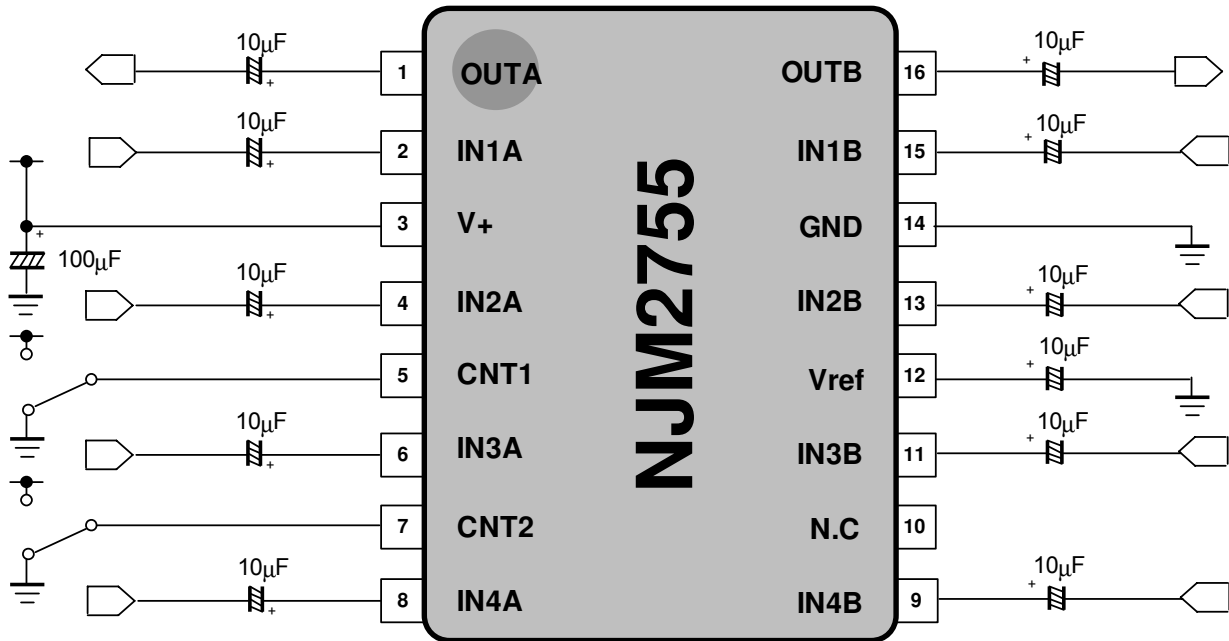

# NJM2755

## APPLICATION CIRCUIT

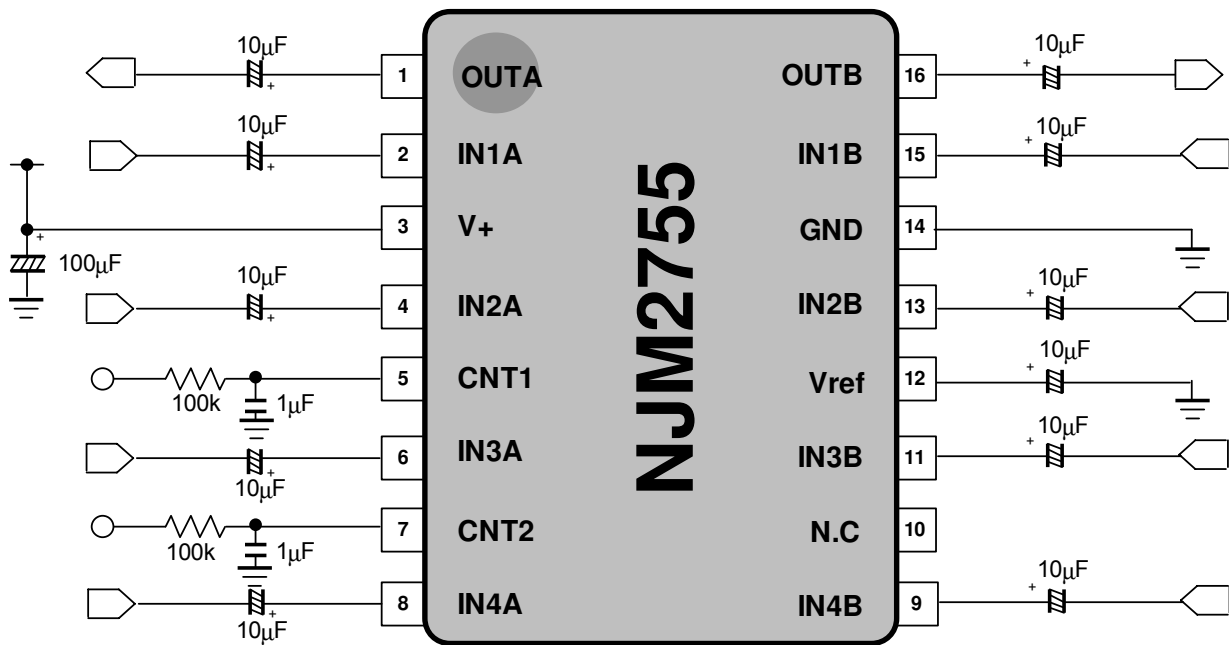

### Application note:

Resistor(100k) and capacitor(1µF) connected to CNT1 are added to reduce pop-noise.

The value of input capacitor connected to IN1A and IN2A depends on cut-off frequency(calculated by  $f_c = 1/2\pi RC$ ) you need. R(input impedance)=100kΩ.

## TYPICAL CHARACTERISTICS

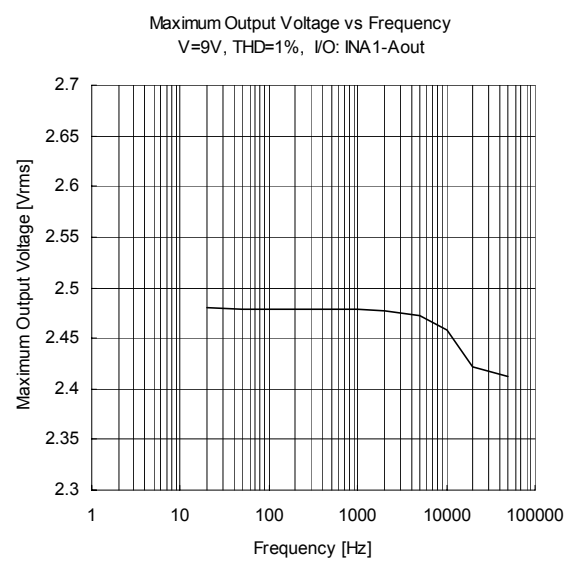
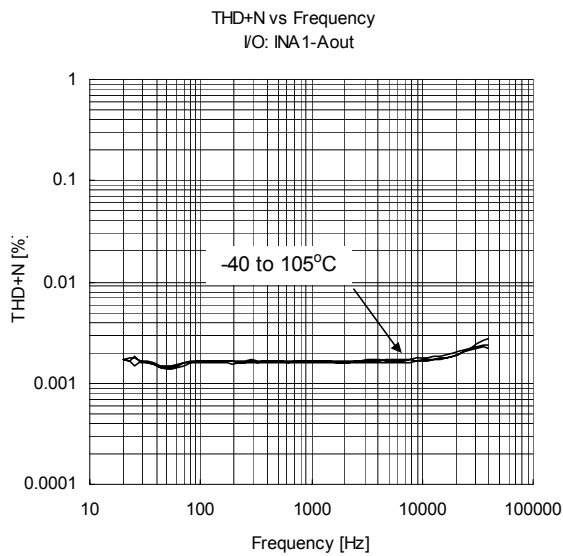
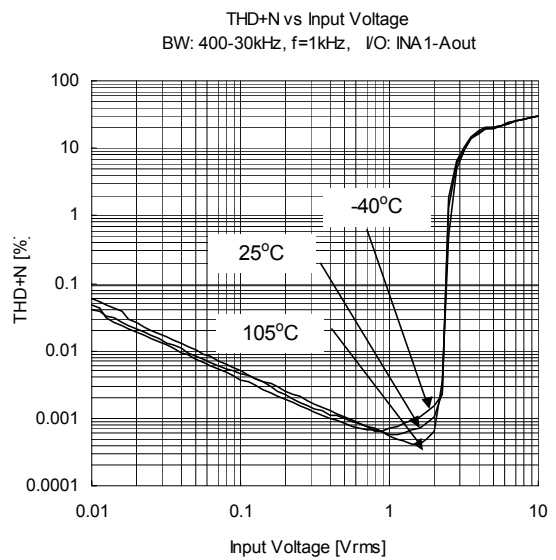
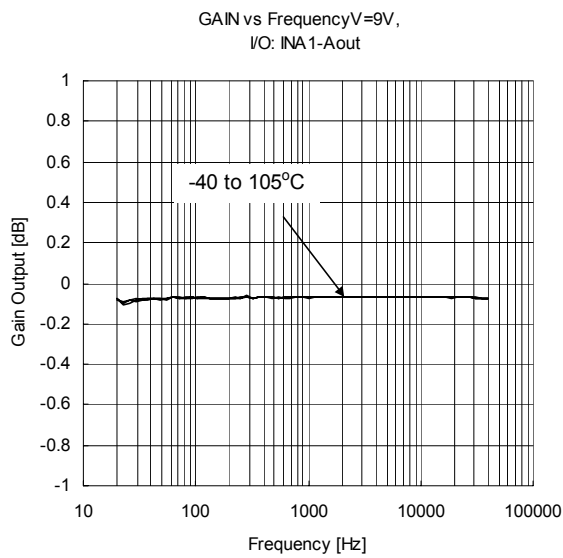
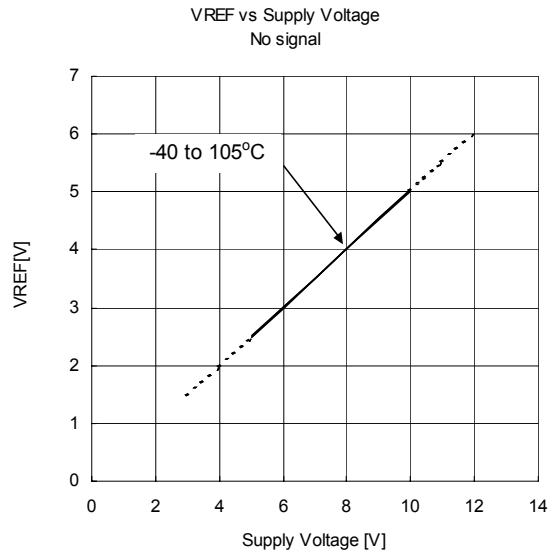
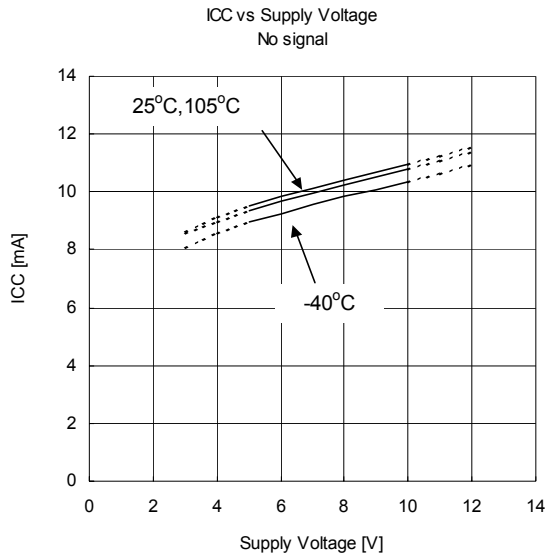



## TYPICAL CHARACTERISTICS

Maximum Output Voltage vs Supply Voltage  
THD=1%, I/O: INA1-1Aout

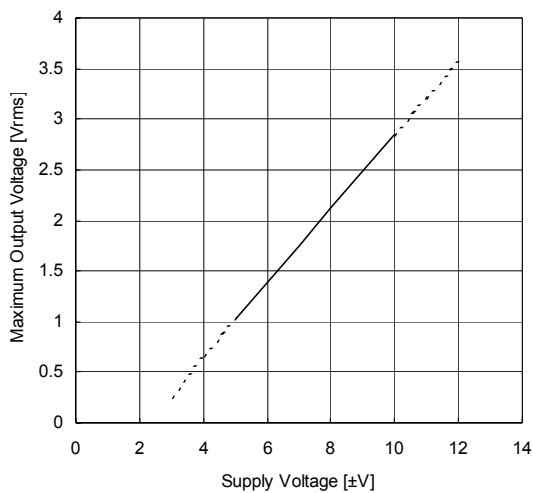

Maximum Output Voltage vs Load Resistance  
V=9V, THD=1%, f=1kHz, I/O: INA1-Aout / INB1-Bout

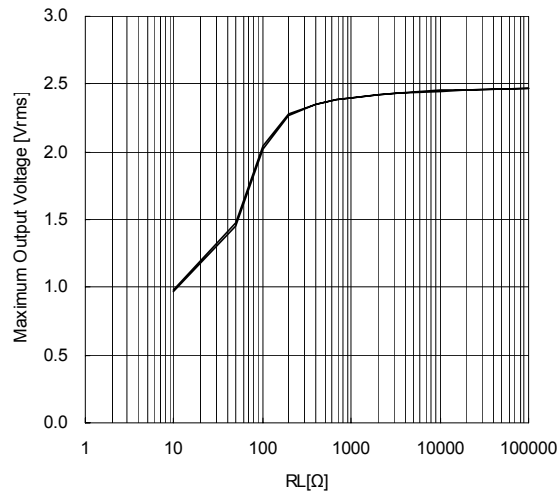

Cross Talk vs Frequency  
V=9V, Vin=1Vrms, BW:10-80kHz,  
I/O: INA2-INA4/Aout, Select Channel:1ch

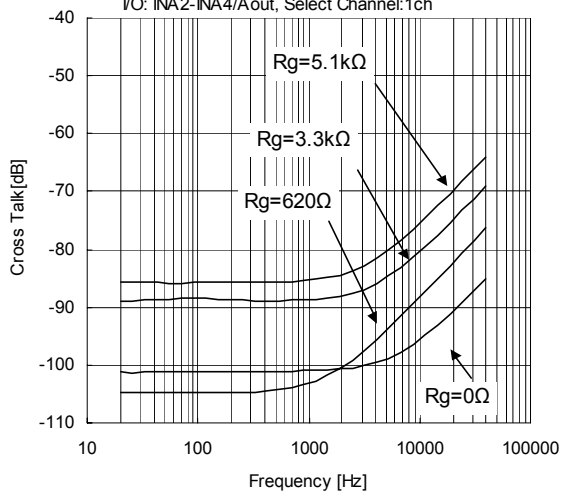

Cross Talk vs Frequency  
V=9V, Vin=1Vrms, BW:10-80kHz,  
I/O: INA2-INA4/Aout, Select Channel:1ch

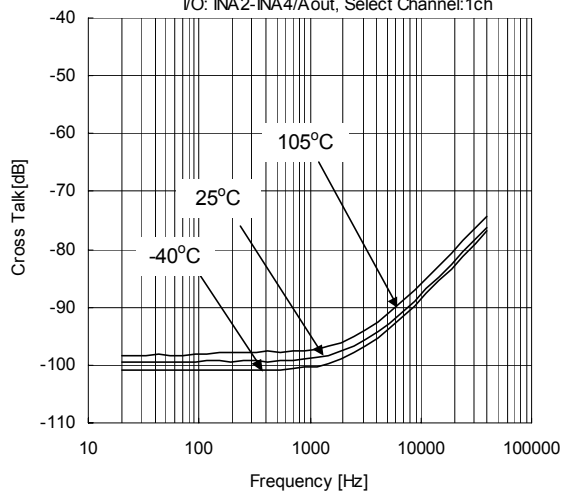

Channel Separation vs Frequency  
V=9V, Vin=1Vrms, BW:10-80kHz,  
I/O: INB1-Aout

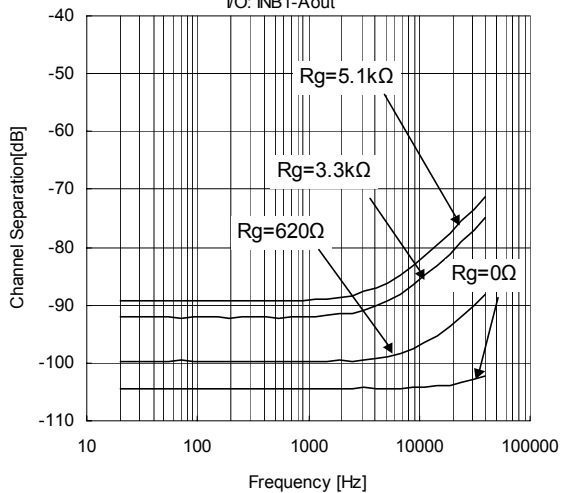

Channel Separation vs Frequency  
V=9V, Vin=1Vrms, BW:10-80kHz,  
I/O: INB1-Aout

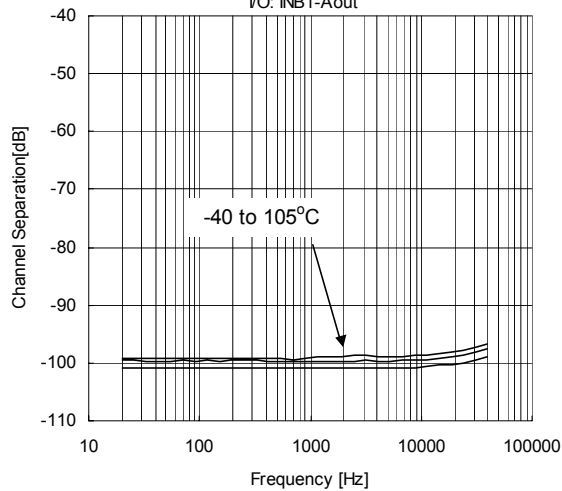

## TYPICAL CHARACTERISTICS

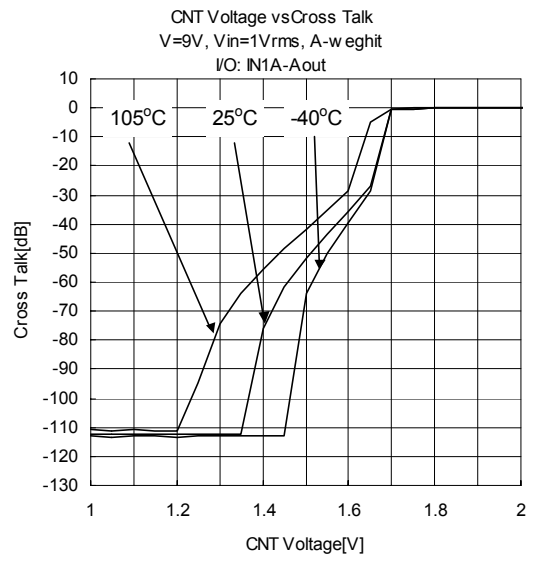
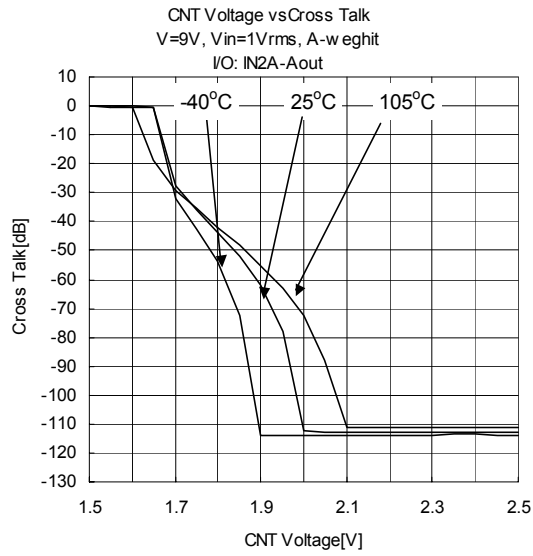

**[CAUTION]**

The specifications on this databook are only given for information, without any guarantee as regards either mistakes or omissions. The application circuits in this databook are described only to show representative usages of the product and not intended for the guarantee or permission of any right including the industrial rights.