



Chipsmall Limited consists of a professional team with an average of over 10 year of expertise in the distribution of electronic components. Based in Hongkong, we have already established firm and mutual-benefit business relationships with customers from,Europe,America and south Asia,supplying obsolete and hard-to-find components to meet their specific needs.

With the principle of “Quality Parts,Customers Priority,Honest Operation,and Considerate Service”,our business mainly focus on the distribution of electronic components. Line cards we deal with include Microchip,ALPS,ROHM,Xilinx,Pulse,ON,Everlight and Freescale. Main products comprise IC,Modules,Potentiometer,IC Socket,Relay,Connector.Our parts cover such applications as commercial,industrial, and automotives areas.

We are looking forward to setting up business relationship with you and hope to provide you with the best service and solution. Let us make a better world for our industry!



Contact us

Tel: +86-755-8981 8866 Fax: +86-755-8427 6832

Email & Skype: info@chipsmall.com Web: www.chipsmall.com

Address: A1208, Overseas Decoration Building, #122 Zhenhua RD., Futian, Shenzhen, China



Designated client product

This product will be discontinued its production in the near term.
And it is provided for customers currently in use only, with a time limit.
It can not be available for your new project. Please select other new or existing products.

For more information, please contact our sales office in your region.

New Japan Radio Co.,Ltd.

<http://www.njr.com/>

LOW-VOLTAGE HEADPHONE AMPLIFIER for PORTABLE-AUDIO

■ GENERAL DESCRIPTION

The **NJM2772** is a low voltage headphone amplifier for portable audio.

The **NJM2772** includes mute circuit, center amplifier and beep input, reduce the external parts, standby circuit and center amplifier with ON/OFF, applies to low current consumption. The mute function reduces the turn-noise at standby mode.

The NJM2772 is suitable for portable MD, CD, and others portable audio system with headphone amplifier.

■ PACKAGE OUTLINE

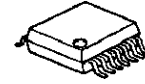

NJM2772V

■ FEATURES

- Operating Voltage $V^+=1.8-4.5V$
- Operating Current 1.2mA typ. @Center Amp. Off
2.0mA typ. @Center Amp. On
- Low Standby Current 18 μ A typ.
- High Output Power 6mWmin. @ $R_L=16\Omega$, THD=10%
- Fixed Gain 11.5dB typ.
- Package Outline SSOP14
- Bipolar Technology

■ PIN CONFIGURATION & BLOCK DIAGRAM

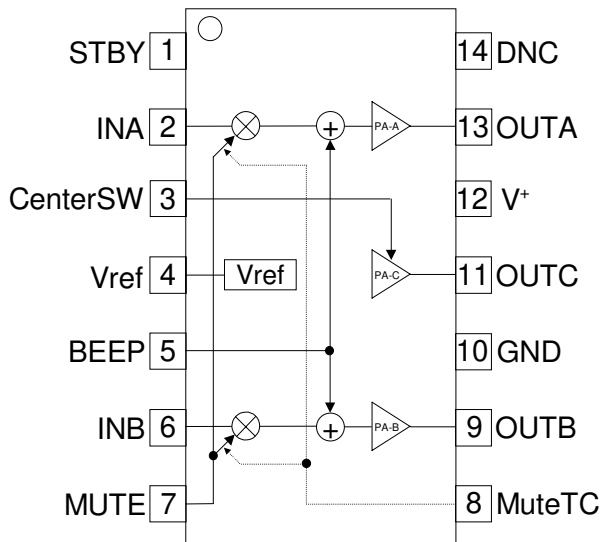

Pin Function	
1.	STBY
2.	INA
3.	CenterSW
4.	V_{REF}
5.	BEEP
6.	INB
7.	MUTE
8.	MuteTC
9.	OUTB
10.	GND
11.	OUTC
12.	V^+
13.	OUTA
14.	DNC

Note)DNC(14pin):Do not connect

NJM2772

■ ABSOLUTE MAXIMUM RATINGS

(Ta=25°C)

PARAMETER	SYMBOL	RATINGS	UNIT
Supply Voltage	V ⁺	5	V
Power Dissipation	P _D	(SSOP14) 300	mW
Operating Temperature Range	T _{opr}	-20 to +75	°C
Storage Temperature Range	T _{stg}	-40 to +125	°C

■ RECOMMENDED OPERATING CONDITIONS

(Ta=25°C)

PARAMETER	SYMBOL	MIN.	TYP.	MAX.	UNIT
Operating Voltage Range	V ⁺	1.8	2.3	4.5	V

■ ELECTRICAL CHARACTERISTICS

(V⁺=2.3V, R_g=600Ω, R_L=16Ω, f=1kHz, STBY-OFF, MUTE-OFF, CA-ON, Ta=25°C)

PARAMETER	SYMBOL	TEST CONDITION	MIN.	TYP.	MAX.	UNIT
Operating Current	I _{CC1}	STANDBY-ON, MUTE-ON	-	18	26	μA
	I _{CC2}	No signal, CA-OFF	-	1.2	2.0	mA
	I _{CC3}	No signal	-	2.0	4.0	mA
	I _{CC4}	P _O =0.5mW+0.5mW, CA-OFF	-	5.8	-	mA
	I _{CC5}	P _O =0.5mW+0.5mW	-	11.7	-	mA
	I _{CC6}	P _O =0.1mW+0.1mW, CA-OFF	-	3.0	-	mA
	I _{CC7}	P _O =0.1mW+0.1mW	-	5.9	-	mA
Reference Voltage	V _{REF}	No signal	0.70	0.75	0.80	V
Voltage Gain	G _V	V _{IN} =-30dBV	10.5	11.5	12.5	dB
Output Power	P _{O1}	THD=10%	6.0	8.0	-	mW
	P _{O2}	V ⁺ 1=1.8V, THD=10%	3.0	4.0	-	
Total Harmonic Distortion	THD	V _{IN} =-30dBV	-	0.1	0.5	%
Output Noise Voltage	V _{NO}	A-Weighted	-	-98 (12.6)	-94 (20)	dBV (μV _{rms})
Cross-talk	CT	V _{IN} =-30dBV, V _O =-18.5dBV	-	-40	-24	dB
Mute Level	MUTE	MUTE-ON, V _{IN} =-30dBV, A-Weighted	-	-95	-80	dBV
Beep Output Voltage	V _{BEEP}	BEEP-IN=2V _{pp}	-55	-50	-45	dBV
Supply Voltage Rejection Ratio	SVR	V ⁺ =1.8V+0.1V _{rms} :1kHz	65	70	-	dB

■ CONTROL TERMINAL CHARACTERISTICS

PARAMETER	SYMBOL	TEST CONDITION	MIN.	TYP.	MAX.	UNIT
H Level Input Voltage	V _{IH}	STBY(1Pin), CSW(3Pin), MUTE(7Pin)	0.8	-	V ⁺	V
L Level Input Voltage	V _{IL}	STBY(1Pin), CSW(3Pin), MUTE(7Pin)	0	-	0.3	V
H Level Input Voltage	V _{BH}	BEEP(5Pin)	0.8	-	V ⁺	V
L Level Input Voltage	V _{BL}	BEEP(5Pin)	0	-	0.3	V

CONTROL TERMINAL EXPLANATION

◆ STBY (1Pin)

PARAMETER	CONTROL SIGNAL	STATUS
STANDBY ON	L	IC is standby.
STANDBY OFF	H	IC is active.

◆ Center-SW (3Pin)

PARAMETER	CONTROL SIGNAL	STATUS
Center Amp. ON	L	Center Amp. is active. Can operate output coupling capacitor less.
Center Amp. OFF	H	When output coupling capacitor is used, realize low current consumption to be Center Amp. OFF.

◆ MUTE (7Pin)

PARAMETER	CONTROL SIGNAL	STATUS
MUTE ON	H	IC output no signal.
MUTE OFF	L	IC output the signal.

APPLICATION CIRCUIT

1) Center Amp. On Mode

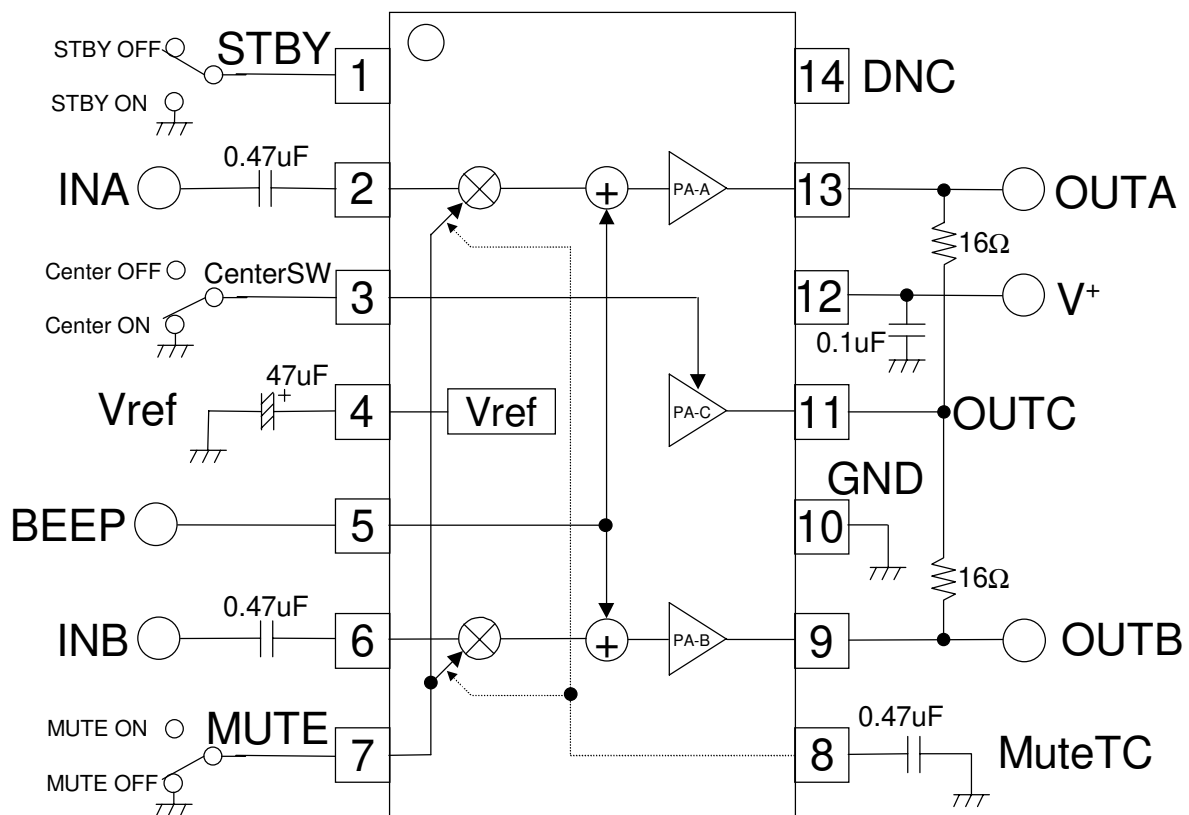

NJM2772

APPLICATION CIRCUIT

2) Center Amp. Off Mode

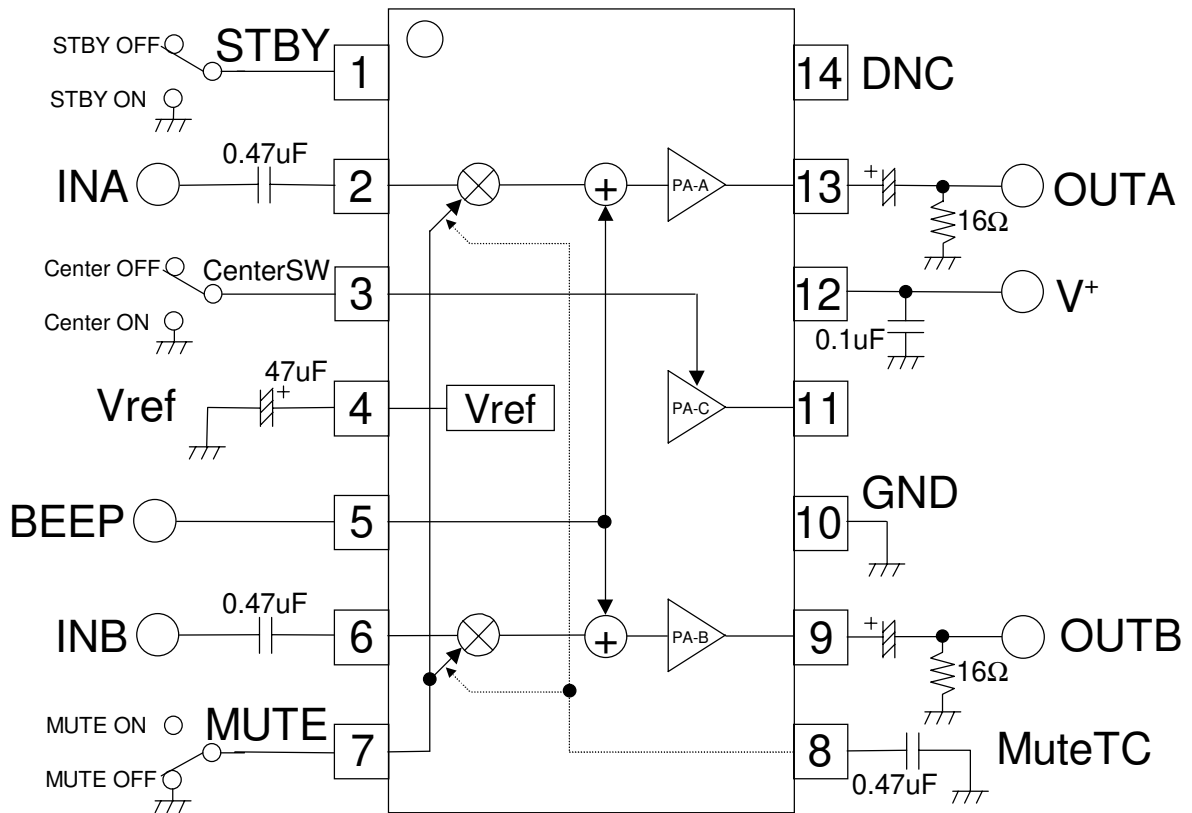

Note) When the BEEP terminal (5pin) is useless, short to GND.

[CAUTION]
The specifications on this databook are only given for information, without any guarantee as regards either mistakes or omissions. The application circuits in this databook are described only to show representative usages of the product and not intended for the guarantee or permission of any right including the industrial rights.