



Chipsmall Limited consists of a professional team with an average of over 10 year of expertise in the distribution of electronic components. Based in Hongkong, we have already established firm and mutual-benefit business relationships with customers from,Europe,America and south Asia,supplying obsolete and hard-to-find components to meet their specific needs.

With the principle of “Quality Parts,Customers Priority,Honest Operation,and Considerate Service”,our business mainly focus on the distribution of electronic components. Line cards we deal with include Microchip,ALPS,ROHM,Xilinx,Pulse,ON,Everlight and Freescale. Main products comprise IC,Modules,Potentiometer,IC Socket,Relay,Connector.Our parts cover such applications as commercial,industrial, and automotives areas.

We are looking forward to setting up business relationship with you and hope to provide you with the best service and solution. Let us make a better world for our industry!



## Contact us

Tel: +86-755-8981 8866 Fax: +86-755-8427 6832

Email & Skype: info@chipsmall.com Web: www.chipsmall.com

Address: A1208, Overseas Decoration Building, #122 Zhenhua RD., Futian, Shenzhen, China



## DUAL STEPPER MOTOR DRIVER

### ■ GENERAL DESCRIPTION

The NJM3772 is a stepper motor driver, which circuit is especially developed for use in microstepping applications in conjunction with the matching dual DAC (Digital-to-Analog Converter) NJU39610.

The NJM3772 contains a clock oscillator, which is common for both driver channels, a set of comparators and flip-flops implementing the switching control, and two H-bridges with internal recirculation diodes. Voltage supply requirements are +5 V for logic and +10 to +45V for the motor. Maximum output current is 1000mA per channel.

### ■ PACKAGE OUTLINE

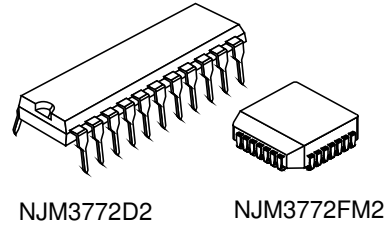

### ■ FEATURES

- Dual chopper driver
- 1000mA continuous output current per channel
- Specially matched to the Dual DAC NJU39610
- Packages DIP22 / PLCC28

### ■ BLOCK DIAGRAM

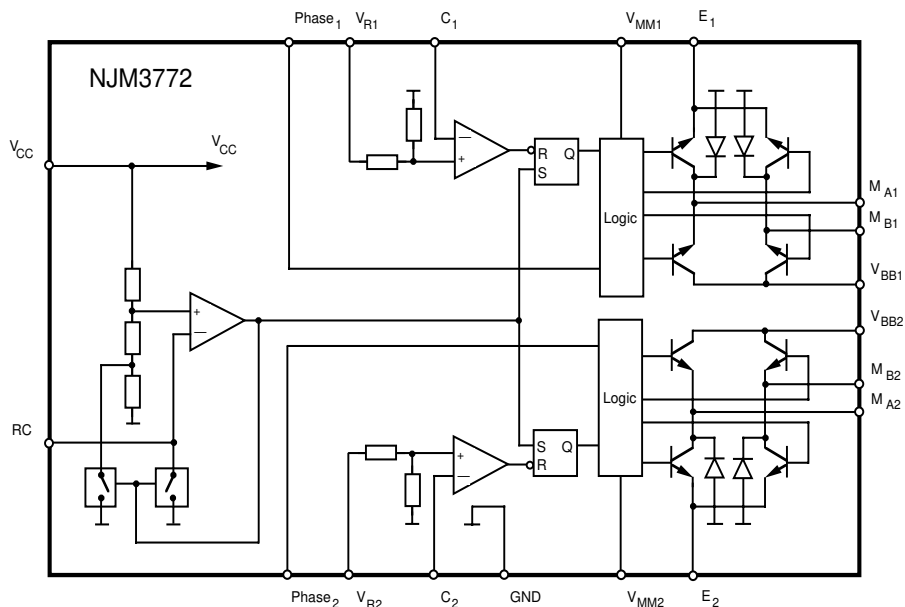

Figure 1. Block diagram

## PIN CONFIGURATIONS

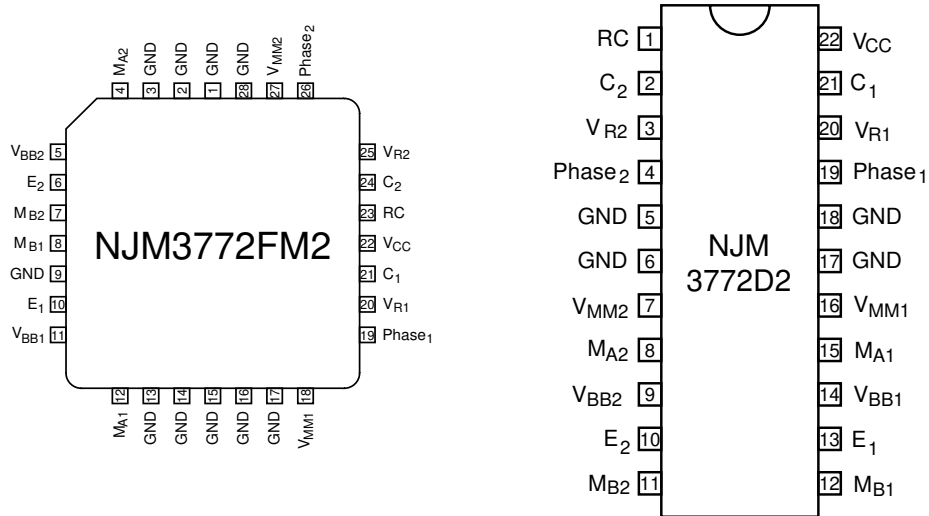

Figure 2. Pin configurations

## PIN DESCRIPTION

PLCC	DIP	Symbol	Description
1-3, 9, 13-17, 28	5, 6, 17, 18	GND	Ground and negative supply. Note: these pins are used thermally for heat-sinking. Make sure that all ground pins are soldered onto a suitably large copper ground plane for efficient heat sinking.
4	8	$M_{A2}$	Motor output A, channel 2. Motor current flows from $M_{A2}$ to $M_{B2}$ when Phase <sub>2</sub> is HIGH.
5	9	$V_{BB2}$	Collector of upper output transistor, channel 2. For lowest possible power dissipation, connect a series resistor $R_{B2}$ to $V_{MM2}$ . See Applications information, External components.
6	10	$E_2$	Common emitter, channel 2. This pin connects to a sensing resistor $R_s$ to ground.
7	11	$M_{B2}$	Motor output B, channel 2. Motor current flows from $M_{A2}$ to $M_{B2}$ when Phase <sub>2</sub> is HIGH.
8	12	$M_{B1}$	Motor output B, channel 1. Motor current flows from $M_{A1}$ to $M_{B1}$ when Phase <sub>1</sub> is HIGH.
10	13	$E_1$	Common emitter, channel 1. This pin connects to a sensing resistor $R_s$ to ground.
11	14	$V_{BB1}$	Collector of upper output transistor, channel 1. For lowest possible power dissipation, connect a series resistor $R_{B1}$ to $V_{MM1}$ . See Applications information, External components.
12	15	$M_{A1}$	Motor output A, channel 1. Motor current flows from $M_{A1}$ to $M_{B1}$ when Phase <sub>1</sub> is HIGH.
18	16	$V_{MM1}$	Motor supply voltage, channel 1, +10 to +40 V. $V_{MM1}$ and $V_{MM2}$ should be connected together.
19	19	Phase <sub>1</sub>	Controls the direction of motor current at outputs $M_{A1}$ and $M_{B1}$ . Motor current flows from $M_{A1}$ to $M_{B1}$ when Phase <sub>1</sub> is HIGH.
20	20	$V_{R1}$	Reference voltage, channel 1. Controls the threshold voltage for the comparator and hence the output current.
21	21	$C_1$	Comparator input channel 1. This input senses the instantaneous voltage across the sensing resistor, filtered by an RC network. The threshold voltage for the comparator is $V_{CH1} = 0.18 \cdot V_{R1}$ [V], i.e. 450 mV at $V_{R1} = 2.5$ V.
22	22	$V_{CC}$	Logic voltage supply, nominally +5 V.
23	1	RC	Clock oscillator RC pin. Connect a 15 kohm resistor to $V_{CC}$ and a 3300 pF capacitor to ground to obtain the nominal switching frequency of 26.5 kHz.
24	2	$C_2$	Comparator input channel 2. This input senses the instantaneous voltage across the sensing resistor, filtered by an RC network. The threshold voltage for the comparator is $V_{CH2} = 0.18 \cdot V_{R2}$ [V], i.e. 450 mV at $V_{R2} = 2.5$ V.
25	3	$V_{R2}$	Reference voltage, channel 2. Controls the threshold voltage for the comparator and hence the output current.
26	4	Phase <sub>2</sub>	Controls the direction of motor current at outputs $M_{A2}$ and $M_{B2}$ . Motor current flows from $M_{A2}$ to $M_{B2}$ when Phase <sub>2</sub> is HIGH.
27	7	$V_{MM2}$	Motor supply voltage, channel 2, +10 to +40 V. $V_{MM1}$ and $V_{MM2}$ should be connected together.

■ FUNCTIONAL DESCRIPTION

Each channel of the NJM3772 consists of the following sections: an output H-bridge with four transistors, capable of driving up to 1000 mA continuous current to the motor winding; a logic section that controls the output transistors; an S-R flip-flop; and a comparator. The clock-oscillator is common to both channels.

Constant current control is achieved by switching the output current to the windings. This is done by sensing the peak current through the winding via a current-sensing resistor  $R_S$ , effectively connected in series with the motor winding during the turn-on period. As the current increases, a voltage develops across the sensing resistor, which is fed back to the comparator. At the predetermined level, defined by the voltage at the reference input  $V_R$ , the comparator resets the flip-flop, which turns off the output transistors. The current decreases until the clock oscillator triggers the flip-flop, which turns on the output transistors again, and the cycle is repeated.

The current paths during turn-on, turn-off and phase shift are shown in figure 3. Note that the upper recirculation diodes are connected to the circuit externally.

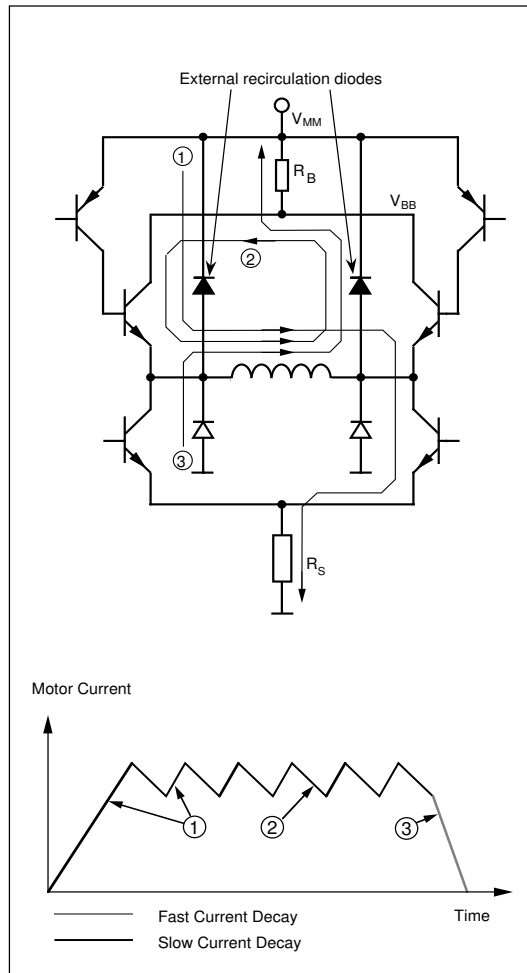

Figure 3. Output stage with current paths during turn-on, turn-off and phase shift.

## ■ ABSOLUTE MAXIMUM RATINGS

Parameter	Pin no. DIP package	Symbol	Min	Max	Unit
<b>Voltage</b>					
Logic supply	22	$V_{CC}$	0	7	V
Motor supply	7, 16	$V_{MM}$	0	45	V
Output stage supply	9, 14	$V_{BB}$	0	45	V
Logic inputs	4, 19	$V_I$	-0.3	6	V
Comparator inputs	2, 21	$V_C$	-0.3	$V_{CC}$	V
Reference inputs	3, 20	$V_R$	-0.3	7.5	V
<b>Current</b>					
Motor output current	8, 11, 12, 15	$I_M$	-1200	+1200	mA
Logic inputs	4, 19	$I_I$	-10	-	mA
Analog inputs	2, 3, 20, 21	$I_A$	-10	-	mA
<b>Temperature</b>					
Operating junction temperature		$T_J$	-40	+150	°C
Storage temperature		$T_S$	-55	+150	°C
<b>Power Dissipation (Package Data)</b>					
Power dissipation at $T_{GND} = +25^\circ\text{C}$ , DIP and PLCC package		$P_D$	-	5	W
Power dissipation at $T_{GND} = +125^\circ\text{C}$ , DIP package		$P_D$	-	2.2	W
Power dissipation at $T_{GND} = +125^\circ\text{C}$ , PLCC package		$P_D$	-	2.6	W

## ■ RECOMMENDED OPERATING CONDITIONS

Parameter	Symbol	Min	Typ	Max	Unit
Logic supply voltage	$V_{CC}$	4.75	5	5.25	V
Motor supply voltage	$V_{MM}$	10	-	40	V
Output stage supply voltage	$V_{BB}$	$V_{MM} - 0.5$	-	$V_{MM}$	V
Motor output current	$I_M$	-1000	-	+1000	mA
Junction temperature **	$T_J$	-20	-	+125	°C
Rise and fall time, logic inputs	$t_r, t_f$	-	-	2	$\mu\text{s}$
Oscillator timing resistor	$R_T$	2	15	20	k $\Omega$

\*\* See operating temperature chapter

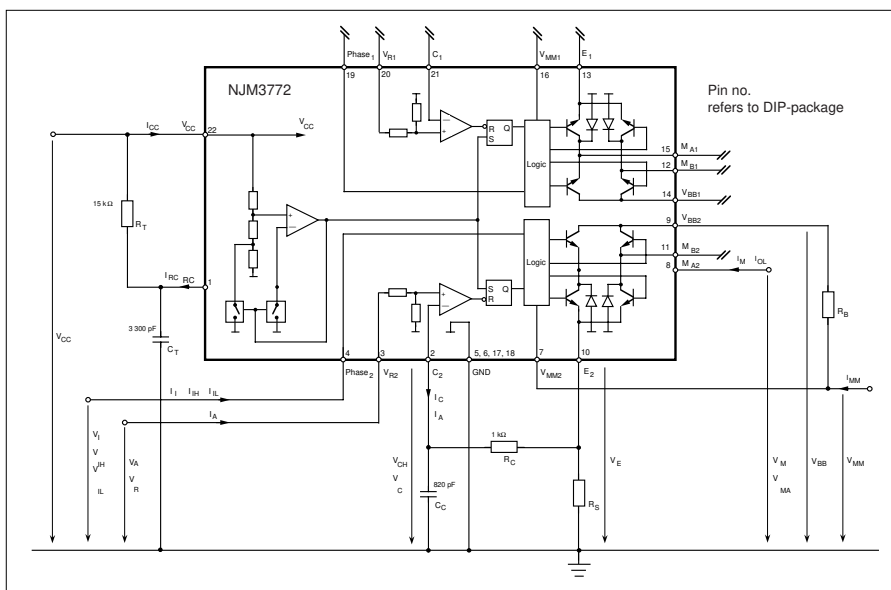

Figure 4. Definition of symbols

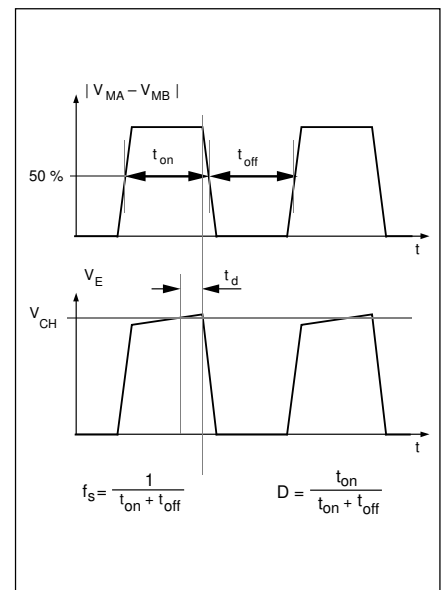

Figure 5. Definition of terms

## ■ ELECTRICAL CHARACTERISTICS

Electrical characteristics over recommended operating conditions, unless otherwise noted.  $-20^{\circ}\text{C} \leq T_J \leq 125^{\circ}\text{C}$

Parameter	Symbol	Conditions	Min	Typ	Max	Unit
<b>General</b>						
Supply current	$I_{CC}$	Note 4.	-	60	75	mA
Total power dissipation	$P_D$	$V_{MM} = 12\text{ V}$ , $I_{M1} = I_{M2} = 750\text{ mA}$ . $R_B = 0.68\text{ ohm}$ . Notes 2, 3, 4, 5.	-	1.8	2.1	W
Total power dissipation	$P_D$	$V_{MM} = 12\text{ V}$ , $I_{M1} = 1000\text{ mA}$ , $I_{M2} = 0\text{ mA}$ . $R_B = 0.47\text{ ohm}$ . Notes 2, 3, 4, 5.	-	1.8	2.2	W
Thermal shutdown junction temperature			-	160	-	$^{\circ}\text{C}$
Turn-off delay	$t_d$	$T_A = +25^{\circ}\text{C}$ , $dV_C/dt \geq 50\text{ mV}/\mu\text{s}$ , $I_M = 100\text{ mA}$ . Note 3.	-	1.4	2.0	$\mu\text{s}$
<b>Logic Inputs</b>						
Logic HIGH input voltage	$V_{IH}$		2.0	-	-	V
Logic LOW input voltage	$V_{IL}$		-	-	0.8	V
Logic HIGH input current	$I_{IH}$	$V_I = 2.4\text{ V}$	-	-	20	$\mu\text{A}$
Logic LOW input current	$I_{IL}$	$V_I = 0.4\text{ V}$	-0.4	-	-	mA
<b>Comparator Inputs</b>						
Threshold voltage	$V_{CH}$	$R_C = 1\text{ kohm}$ , $V_R = 2.50\text{ V}$	430	450	470	mV
$ V_{CH1} - V_{CH2} $ mismatch	$V_{CH,diff}$	$R_C = 1\text{ kohm}$	-	1	-	mV
Input current	$I_C$		-10	-	1	$\mu\text{A}$
<b>Reference Inputs</b>						
Input resistance	$R_R$	$T_A = +25^{\circ}\text{C}$	-	5	-	kohm
Input current	$I_R$	$V_R = 2.50\text{ V}$	-	0.5	1.0	mA
<b>Motor Outputs</b>						
Lower transistor saturation voltage		$I_M = 750\text{ mA}$	-	0.6	0.9	V
Lower transistor leakage current		$V_{MM} = 41\text{ V}$ , $V_E = V_R = 0\text{ V}$ , $V_C = V_{CC}$	-	-	700	$\mu\text{A}$
Lower diode forward voltage drop		$I_M = 750\text{ mA}$	-	1.2	1.5	V
Upper transistor saturation voltage		$I_M = 750\text{ mA}$ . $R_B = 0.68\text{ ohm}$ . Note 5	-	0.6	0.9	V
Upper transistor saturation voltage		$I_M = 750\text{ mA}$ . $R_B = 0.47\text{ ohm}$ . Note 3, 5	-	0.8	1.1	V
Upper transistor leakage current		$V_{MM} = V_{BB} = 41\text{ V}$ , $V_E = V_R = 0\text{ V}$ , $V_C = V_{CC}$	-	-	700	$\mu\text{A}$
<b>Chopper Oscillator</b>						
Chopping frequency	$f_s$	$C_T = 3300\text{ pF}$ , $R_T = 15\text{ kohm}$	25.0	26.5	28.0	kHz

## ■ THERMAL CHARACTERISTICS

Parameter	Symbol	Conditions	Min	Typ	Max	Unit
Thermal resistance	$R_{th_{J-GND}}$	DIP package	-	11	-	$^{\circ}\text{C}/\text{W}$
	$R_{th_{J-A}}$	DIP package. Note 2	-	40	-	$^{\circ}\text{C}/\text{W}$
	$R_{th_{J-GND}}$	PLCC package	-	9	-	$^{\circ}\text{C}/\text{W}$
	$R_{th_{J-A}}$	PLCC package. Note 2	-	35	-	$^{\circ}\text{C}/\text{W}$

### Notes

1. All voltages are with respect to ground. Currents are positive into, negative out of specified terminal
2. All ground pins soldered onto a  $20\text{ cm}^2$  PCB copper area with free air convection,  $T_A = +25^{\circ}\text{C}$
3. Not covered by final test program
4. Switching duty cycle  $D = 30\%$ ,  $f_s = 26.5\text{ kHz}$
5. External resistors  $R_B$  for lowering of saturation voltage

## APPLICATIONS INFORMATION

### Current control

The output current to the motor winding is determined by the voltage at the reference input and the sensing resistor,  $R_S$ .

Chopping frequency, winding inductance and supply voltage also affect the current, but to much less extent.

The peak current through the sensing resistor (and motor winding) can be expressed as:

$$I_{M,peak} = 0.18 \cdot (V_R / R_S) [A]$$

i.e., with a recommended value of

0.47 ohm for the sensing resistor  $R_S$ , a 2.5 V reference voltage will produce an output current of approximately 960 mA.

To improve noise immunity on the  $V_R$  input, the control range may be increased to 5 V if  $R_S$  is correspondingly changed to 1 ohm.

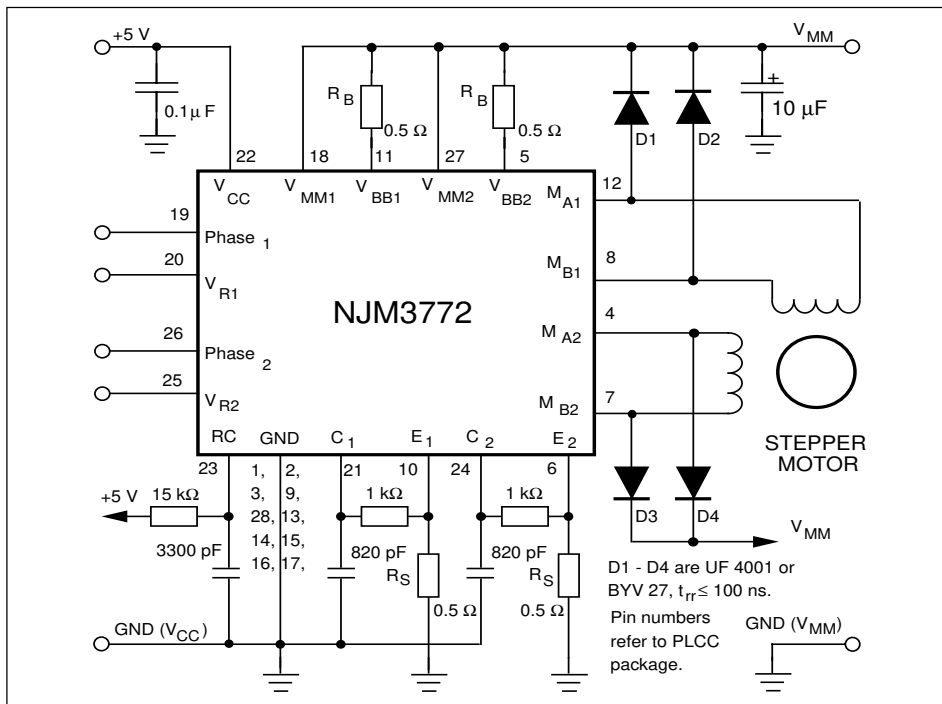

Figure 6. Typical stepper motor driver application with NJM3772

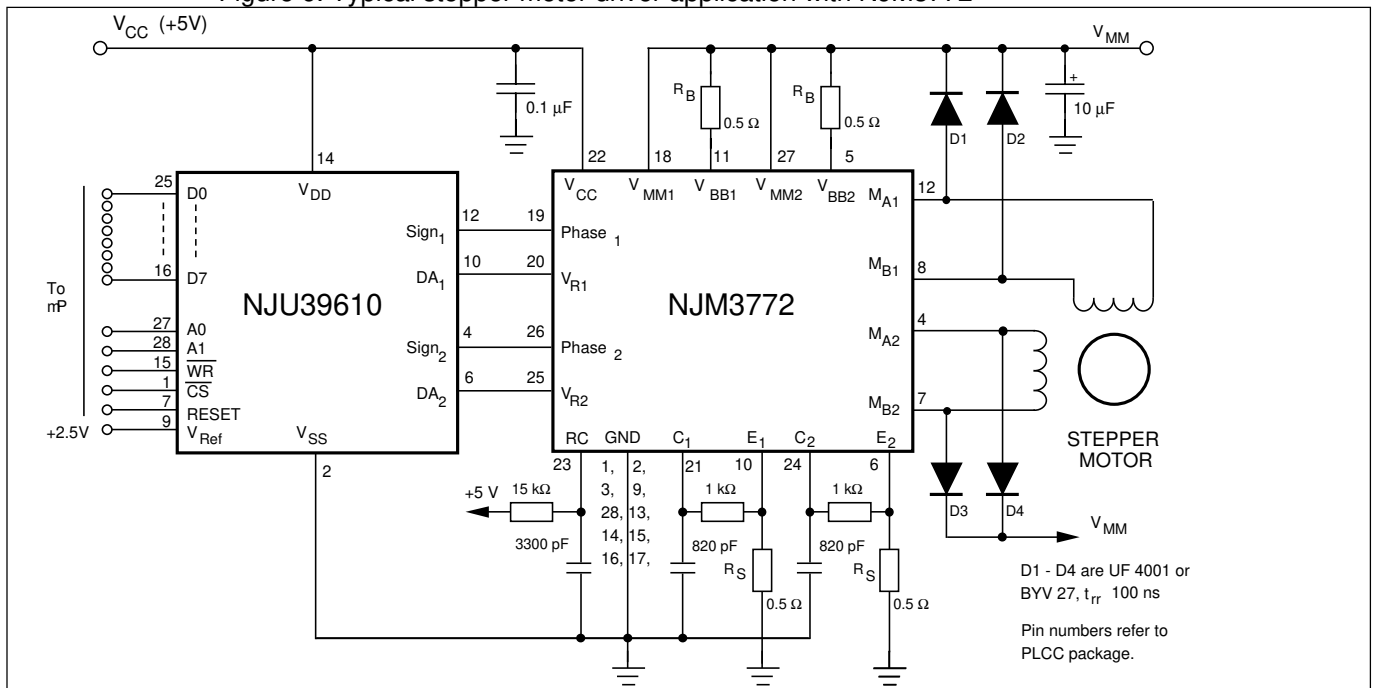

Figure 7. Microstepping system with NJU39610 and NJM3772

## External components

The NJM3772 exhibits substantially less power dissipation than most other comparable stepper motor driver ICs on the market. This has been achieved by creating an external voltage drop in series with the upper transistor in the output H-bridge, see figure 3. The voltage drop reduces the collector-emitter saturation voltage of the internal transistor, which can greatly reduce power dissipation of the IC itself. The series resistor, designated  $R_B$ , shall be selected for about 0.5 V voltage drop at the maximum output current. In an application with an output current of 1000 mA (peak), a 0.47 ohm, 1/2 W resistor is the best choice.

In low current applications where power dissipation is not a critical factor, the  $R_B$  resistor can of course be omitted, and the  $V_{MM}$  and  $V_{BB}$  pins (pins 5, 11, 18, 27) can all be connected directly to the motor supply voltage  $V_{MM}$ . Contributing to the low power dissipation is the fact that the upper recirculation diodes in the output H- bridge are connected externally to the circuit. These diodes shall be of fast type, with a  $t_{rr}$  of less than 100 ns. Common types are UF4001 or BYV27.

A low pass filter in series with the comparator input prevents erroneous switching due to switching transients. The recommended filter component values, 1 kohm and 820 pF, are suitable for a wide range of motors and operational conditions.

Since the low-pass filtering action introduces a small delay of the signal to the comparator, peak voltage across the sensing resistor, and hence the peak motor current, will reach a slightly higher level than than what is defined by the comparator threshold,  $V_{CH}$ , set by the reference input  $V_R$  ( $V_{CH} = 450$  mV at  $V_R = 2.5$  V).

The time constant of the low-pass filter may therefore be reduced to minimize the delay and optimize low-current performance. Increasing the time constant may result in unstable switching. The time constant should be adjusted by changing the  $C_C$  value.

The frequency of the clock oscillator is set by the  $R_T$ - $C_T$  timing components at the RC pin. The recommended values result in a clock frequency (= switching frequency) of 26.5 kHz. A lower frequency will result in higher current ripple, but may improve low-current level linearity. A higher clock frequency reduces current ripple, but increases the switching losses in the IC and possibly the iron losses in the motor. If the clock frequency needs to be changed, the  $C_T$  capacitor value should be adjusted. The recommended  $R_T$  resistor value is 15 kohm.

The sensing resistor  $R_S$ , should be selected for maximum motor current. The relationship between peak motor current, reference voltage and the value of  $R_S$  is described under Current control above. Be sure not to exceed the maximum output current which is 1200 mA peak when only one channel is activated. Or recommended output current, which is 1000 mA peak, when both channels is activated.



## Motor selection

The NJM3772 is designed for two-phase bipolar stepper motors, i.e., motors that have only one winding per phase.

The chopping principle of the NJM3772 is based on a constant frequency and a varying duty cycle. This scheme imposes certain restrictions on motor selection. Unstable chopping can occur if the chopping duty cycle exceeds approximately 50%. See figure 5 for definitions. To avoid this, it is necessary to choose a motor with a low winding resistance and inductance, i.e. windings with a few turns.

It is not possible to use a motor that is rated for the same voltage as the actual supply voltage. Only rated current needs to be considered. Typical motors to be used together with the NJM3772 have a voltage rating of 1 to 6 V, while the supply voltage usually ranges from 12 to 40 V.

Low inductance, especially in combination with a high supply voltage, enables high stepping rates. However, to give the same torque capability at low speed, a reduced number of turns in the winding must be compensated by a higher current. A compromise has to be made.

Choose a motor with the lowest possible winding resistance that still gives the required torque, and use as high supply voltage as possible, without exceeding the maximum recommended 40 V. Check that the chopping duty cycle does not exceed 50% at maximum current.

## Phase inputs.

A logic HIGH on a Phase input gives a current flowing from pin  $M_A$  into pin  $M_B$ . A logic LOW gives a current flow in the opposite direction. A time delay prevents cross conduction in the H-bridge when changing the Phase input.

## Heat sinking.

Soldering the batwing ground leads onto a copper ground plane of 20 cm<sup>2</sup> (approx. 1.8" x 1.8"), copper foil thickness 35  $\mu$ m, permits the circuit to operate with 750 mA output current, both channels driving, at ambient temperatures up to 70°C. Consult figures 8, 9, 10 and 11 in order to determine the necessary copper ground plane area for heat sinking at higher current levels.

## Thermal shutdown.

The circuit is equipped with a thermal shutdown function that turns the output off at chip temperatures above 160°C. Normal operation is resumed when the temperature has decreased.

## Operating temperature.

The max recommended operating temperature is 125°C. This gives an estimated lifelength of about 5 years at continuous drive, A change of  $\pm 10^\circ$  would increase/decrease the lifelength of the circuit about 5 years.

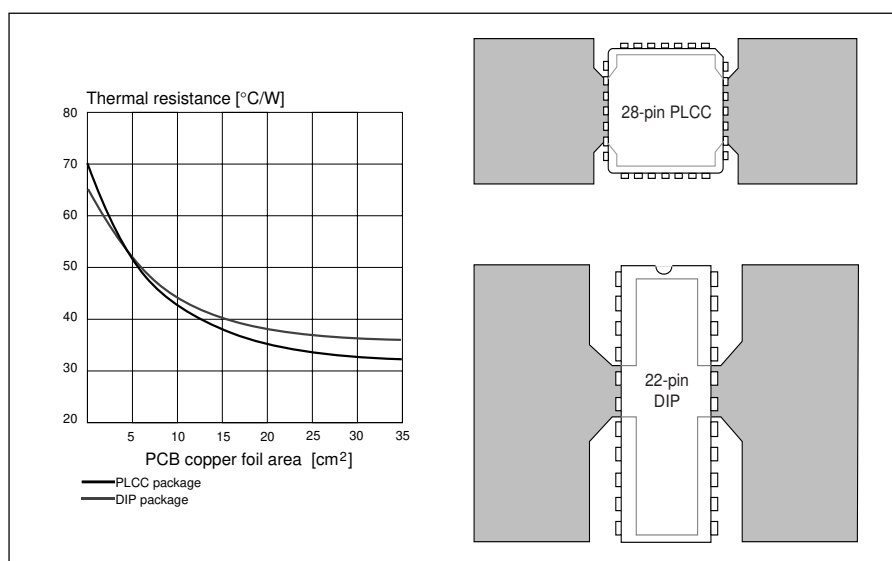

Figure 8. Typical thermal resistance vs. PC Board copper area and suggested layout

■ TYPICAL CHARACTERISTICS

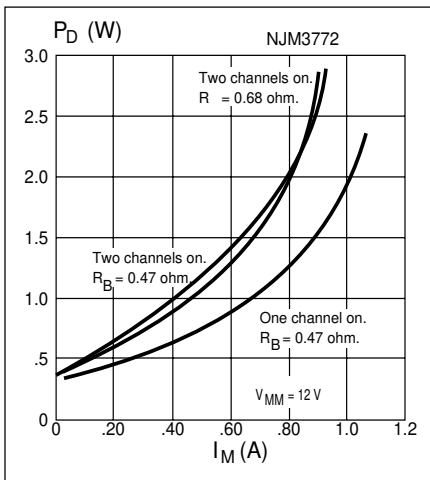

Figure 9. Power dissipation vs. motor current.  $T_a = 25^\circ\text{C}$

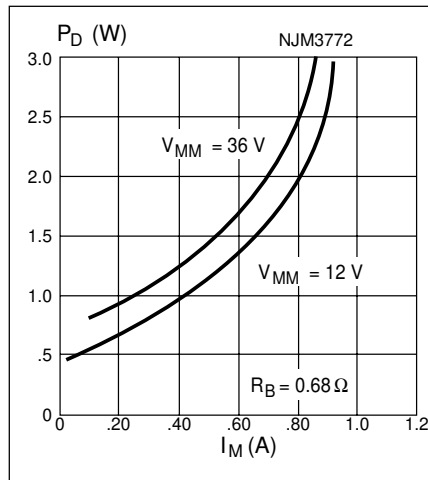

Figure 10. Power dissipation vs. motor current, both channels on.  $T_a = 25^\circ\text{C}$

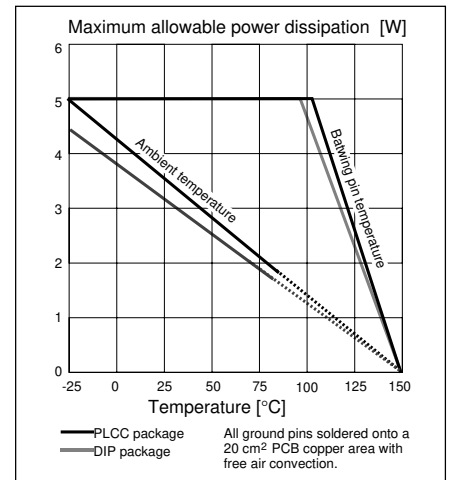

Figure 11. Maximum allowable power dissipation vs. temperature

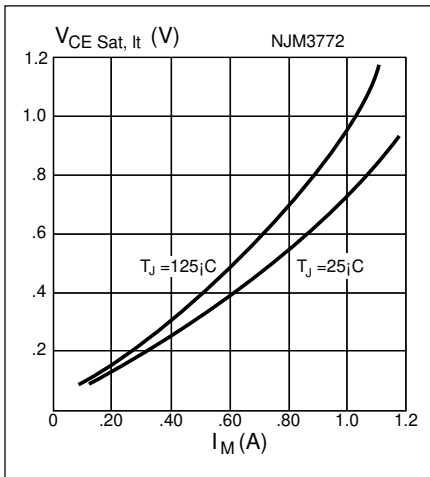

Figure 12. Typical lower transistor saturation voltage vs. output current

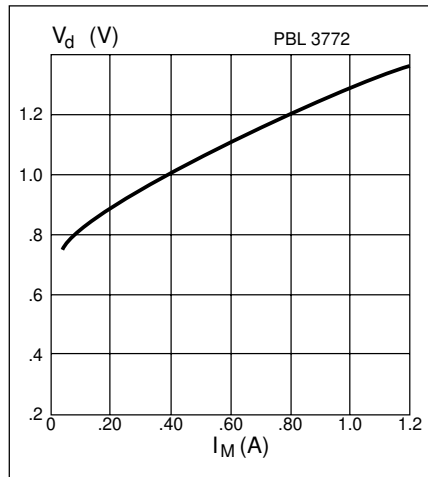

Figure 13. Typical lower diode voltage drop vs. recirculating current

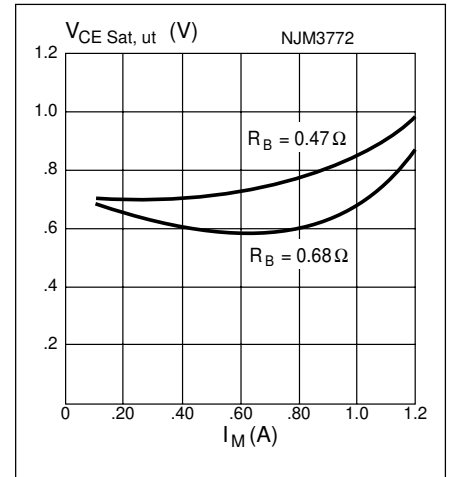

Figure 14. Typical upper transistor saturation voltage vs. output current

The specifications on this databook are only given for information, without any guarantee as regards either mistakes or omissions. The application circuits in this databook are described only to show representative usages of the product and not intended for the guarantee or permission of any right including the industrial rights.