



Chipsmall Limited consists of a professional team with an average of over 10 year of expertise in the distribution of electronic components. Based in Hongkong, we have already established firm and mutual-benefit business relationships with customers from,Europe,America and south Asia,supplying obsolete and hard-to-find components to meet their specific needs.

With the principle of “Quality Parts,Customers Priority,Honest Operation,and Considerate Service”,our business mainly focus on the distribution of electronic components. Line cards we deal with include Microchip,ALPS,ROHM,Xilinx,Pulse,ON,Everlight and Freescale. Main products comprise IC,Modules,Potentiometer,IC Socket,Relay,Connector.Our parts cover such applications as commercial,industrial, and automotives areas.

We are looking forward to setting up business relationship with you and hope to provide you with the best service and solution. Let us make a better world for our industry!



## Contact us

Tel: +86-755-8981 8866 Fax: +86-755-8427 6832

Email & Skype: info@chipsmall.com Web: www.chipsmall.com

Address: A1208, Overseas Decoration Building, #122 Zhenhua RD., Futian, Shenzhen, China



## 16-BIT SERIAL TO PARALLEL CONVERTER

### ■ GENERAL DESCRIPTION

The **NJU3716** is a 16-bit serial to parallel converter especially applying to MPU output expander.

The effective output assignment of MPU is available as the connection between **NJU3716** and MPU using only 4 lines.

The serial data synchronizing with 5MHz or more clock can be input to the serial data input terminal and the data are output from parallel output buffer through serial in parallel out shift register and parallel data latches.

Furthermore, the **NJU3716** outputs the serial data from SO terminal through the shift register. Therefore, it connects with other SIPO ICs like as NJU3711 in cascade for expanding the parallel conversion outputs.

The hysteresis input circuit realizes wide noise margin and the high drive-ability output buffer (25mA) can drive LED directly.

### ■ PACKAGE OUTLINE

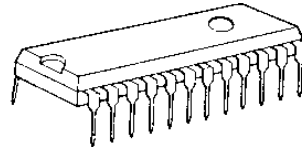

NJU3716L

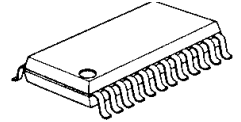

NJU3716M

### ■ FEATURES

- 16-Bit Serial In Parallel Out
- Hysteresis Input           0.5V typ
- Operating Voltage        5V±10%
- Maximum Operating Frequency 5MHz and more
- Output Current           25mA
- C-MOS Technology
- Package Outline           SDIP24/DMP24

### ■ PIN CONFIGURATION

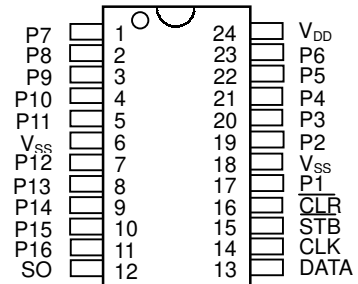

NJU3716L/M

### ■ BLOCK DIAGRAM

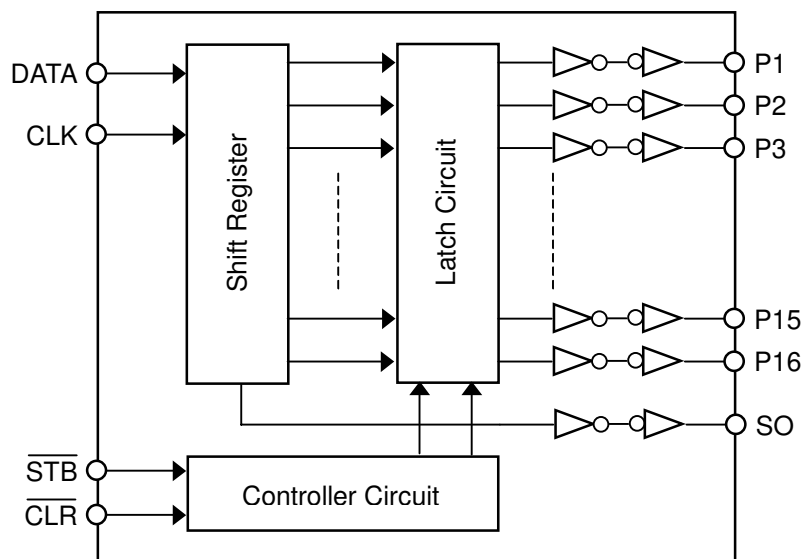

## ■ TERMINAL DESCRIPTION

No.	SYMBOL	I/O	FUNCTION
1	P7	O	Parallel Conversion Data Output Terminals
2	P8	O	
3	P9	O	
4	P10	O	
5	P11	O	
6	V <sub>SS</sub>	-	GND
7	P12	O	Parallel Conversion Data Output Terminals
8	P13	O	
9	P14	O	
10	P15	O	
11	P16	O	
12	SO	O	Serial Data Output Terminal
13	DATA	I	Serial Data Input Terminal
14	CLK	I	Clock Signal Input Terminal
15	STB	I	Strobe Signal Input Terminal
16	CLR	I	Clear Signal Input Terminal
17	P1	O	Parallel Conversion Data Output Terminal
18	V <sub>SS</sub>	-	GND
19	P2	O	Parallel Conversion Data Output Terminals
20	P3	O	
21	P4	O	
22	P5	O	
23	P6	O	
24	V <sub>DD</sub>	-	Power Supply Terminal (4.5 to 5.5V)

## ■ FUNCTIONAL DESCRIPTION

### (1) Reset

When the "L" level is input to the  $\overline{\text{CLR}}$  terminal, all latches are reset and all of parallel conversion output are "L" level.

Normally, the  $\overline{\text{CLR}}$  terminal should be "H" level.

### (2) Data Transmission

In the  $\overline{\text{STB}}$  terminal is "H" level and the clock signals are inputted to the CLK terminal, the serial data into the DATA terminal are shifted in the shift register synchronizing at a rising edge of the clock signal.



When the  $\overline{\text{STB}}$  terminal is changed to "L" level, the data in the shift register are transferred to the latches.

Even if the  $\overline{\text{STB}}$  terminal is "L" level, the input clock signal shifts the data in the shift register, therefore, the clock signal should be controlled for data order.

### (3) Cascade Connection

The serial data input from DATA terminal is output from the SO terminal through internal shift register unrelated with the  $\overline{\text{CLR}}$  and  $\overline{\text{STB}}$  status.

Furthermore, the 4 input circuits provide a hysteresis characteristics using the schmitt trigger structure to protect the noise.

CLK	$\overline{\text{STB}}$	$\overline{\text{CLR}}$	OPERATION
X	X	L	All of latches are reset (the data in the shift register is no change). All of parallel conversion outputs are "L".
	H	H	The serial data into the DATA terminal are inputted to the shift register. In this stage, the data in the latch is not changed.
L	L	H	The data in the shift register is transferred to the latch. And the data in the latch is output from the parallel conversion output terminals.
H			
			When the clock signal is inputted into the CLK terminal in state of the $\overline{\text{STB}}="L"$ and $\overline{\text{CLR}}="H"$ , the data is shifted in the shift register and latched data is also changed in accordance with the shift register.

Note 1) X: Don't care

## ■ TIMING CHART

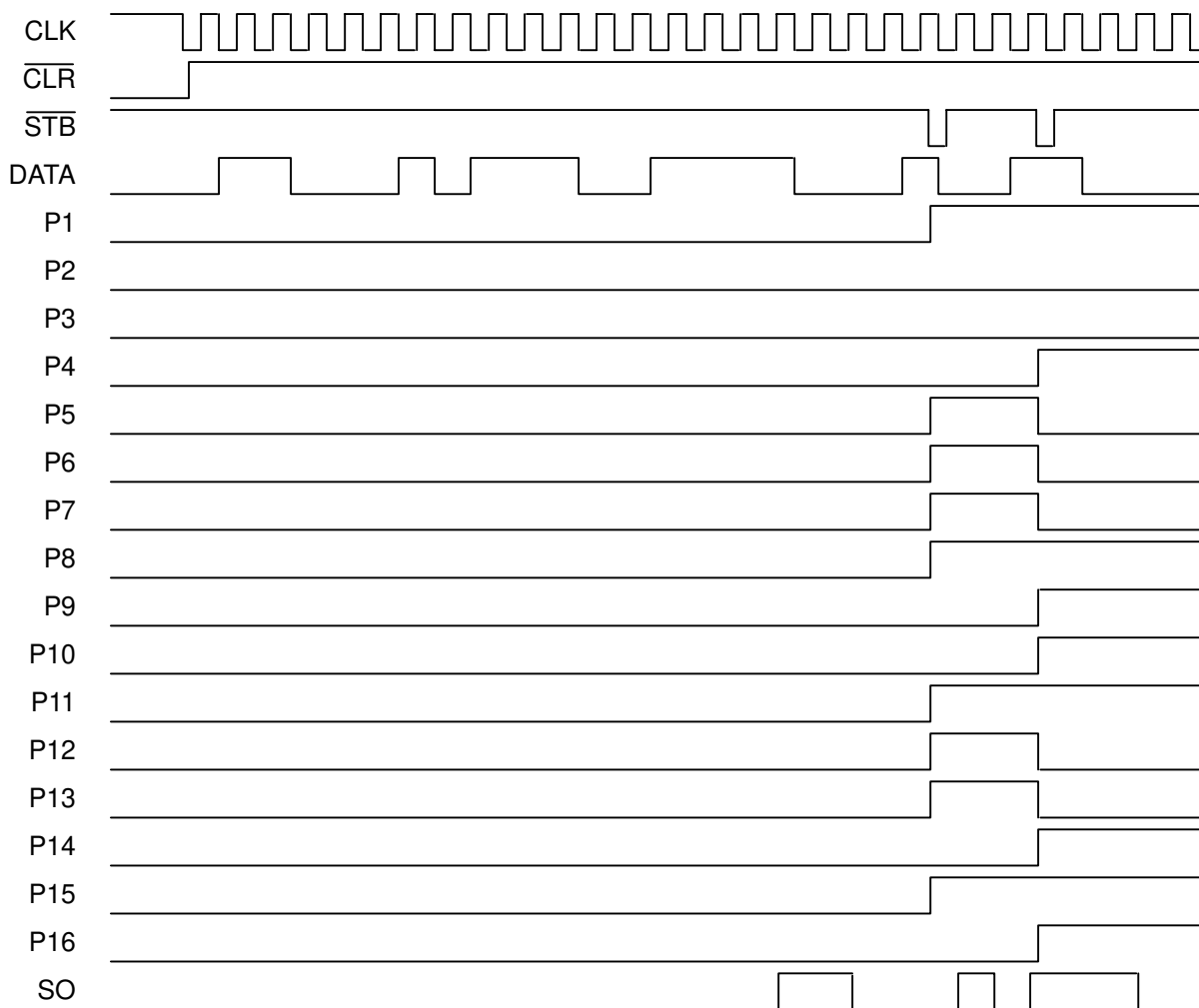

## ■ ABSOLUTE MAXIMUM RATINGS

(Ta=25°C)

PARAMETER	SYMBOL	RATINGS		UNIT
Supply Voltage Range	$V_{DD}$	-0.5 ~ +7.0		V
Input Voltage Range	$V_I$	$V_{SS}-0.5 \sim V_{DD}+0.5$		V
Output Voltage Range	$V_O$	$V_{SS}-0.5 \sim V_{DD}+0.5$		V
Output Current	$I_O$	±25		mA
Output Short Current (SO Terminal) (Note 5)	$I_{OS}$	$V_O=7V, V_I=0V$	10 (max)	mA
		$V_O=0V, V_I=7V$	-10 (max)	
Output Short Current (P1~P16 Terminals) (Note 5)	$I_{OSD}$	$V_O=7V, V_I=0V$	20 (max)	mA
		$V_O=0V, V_I=7V$	-20 (max)	
Power Dissipation	$P_D$	700 (SDIP) 500 (DMP)		mW
Operating Temperature Range	$T_{opr}$	-25 ~ +85		°C
Storage Temperature Range	$T_{stg}$	-65 ~ +150		°C

Note 2) All voltage are relative to  $V_{SS}=0V$  reference.

Note 3) Do not exceed the absolute maximum ratings, otherwise the stress may cause a permanent damage to the IC. It is also recommended that the IC be used in the range specified in the DC electrical characteristics, or the electrical stress may cause malfunctions and impact on the reliability.

Note 4) To stabilize the IC operation, place decoupling capacitor between  $V_{DD}$  and  $V_{SS}$ .

Note 5)  $V_{DD}=7V, V_{SS}=0V$ , less than 1 second per pin.

## ■ DC ELECTRICAL CHARACTERISTICS

( $V_{DD}=4.5\sim 5.5V, V_{SS}=0V, T_a=25^\circ C$ , unless otherwise noted)

PARAMETER	SYMBOL	CONDITION		MIN	TYP	MAX	UNIT
Operating Voltage	$V_{DD}$			4.5	-	5.5	V
Operating Current	$I_{DDs}$	$V_{IH}=V_{DD}, V_{IL}=V_{SS}$		-	-	0.1	mA
High-level Output Voltage	$V_{OH}$	$I_{OH}=-0.4mA$	SO Terminal	4.0	-	$V_{DD}$	V
Low-level Output Voltage	$V_{OL}$	$I_{OL}=+3.2mA$		$V_{SS}$	-	0.4	V
High-level Input Voltage	$V_{IH}$			$0.7V_{DD}$	-	$V_{DD}$	V
Low-level Input Voltage	$V_{IL}$			$V_{SS}$	-	$0.3V_{DD}$	V
Input Leakage Current	$I_{LI}$	$V_I=0\sim V_{DD}$		-10	-	10	μA
High-level Output Voltage (Note 6)	$V_{OHD}$	$I_{OH}=-25mA$	P1~P16 Terminals	$V_{DD}-1.5$	-	$V_{DD}$	V
		$I_{OH}=-15mA$		$V_{DD}-1.0$	-	$V_{DD}$	
		$I_{OH}=-10mA$		$V_{DD}-0.5$	-	$V_{DD}$	
Low-level Output Voltage (Note 6)	$V_{OLD}$	$I_{OL}=+25mA$	P1~P16 Terminals	$V_{SS}$	-	1.5	V
		$I_{OL}=+15mA$		$V_{SS}$	-	0.8	
		$I_{OL}=+10mA$		$V_{SS}$	-	0.4	

Note 6) Specified value represent output current per pin. When use, total current consideration and less than power dissipation in rating operation should be required.

# NJU3716

## ■ SWITCHING CHARACTERISTICS

( $V_{DD}=4.5\sim 5.5V$ ,  $V_{SS}=0V$ ,  $T_a=25^\circ C$ , unless otherwise noted)

PARAMETER	SYMBOL	CONDITION	MIN	TYP	MAX	UNIT
Set-Up Time	$t_{SD}$	DATA-CLK	20	-	-	ns
Hold Time	$t_{HD}$	CLK-DATA	20	-	-	ns
Set-Up Time	$t_{SSTB}$	$\overline{STB}$ -CLK	30	-	-	ns
Hold Time	$t_{HSTB}$	CLK- $\overline{STB}$	30	-	-	ns
Output Delay Time	$t_{pdO}$	CLK-SO	-	-	70	ns
	$t_{pdPCK}$	CLK-P1~P16	-	-	100	ns
	$t_{pdPSTB}$	$\overline{STB}$ -P1~P16	-	-	80	ns
	$t_{pdPCLR}$	$\overline{CLR}$ -P1~P16	-	-	80	ns
Maximum Operating Frequency	$f_{MAX}$		5	-	-	MHz

Note 7)  $C_{OUT}=50pF$

## SWITCHING CHARACTERISTICS TEST WAVEFORM

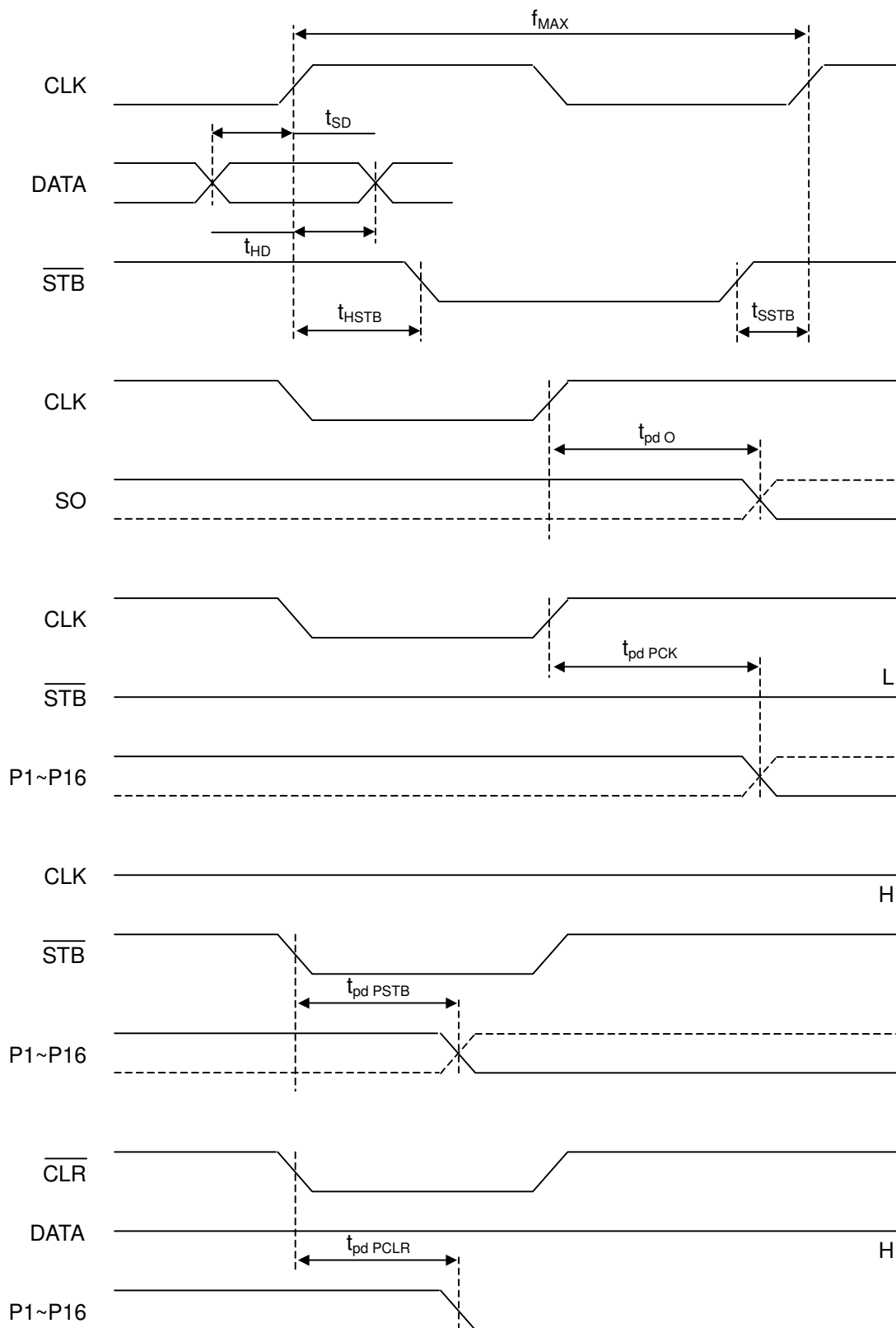



# NJU3716

## ■ APPLICATION CIRCUIT (1)

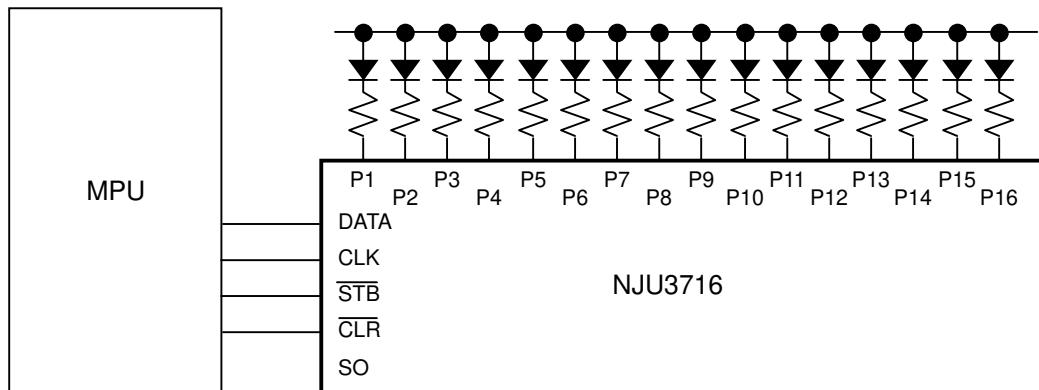

## ■ APPLICATION CIRCUIT (2) (Combined with NJU3711)

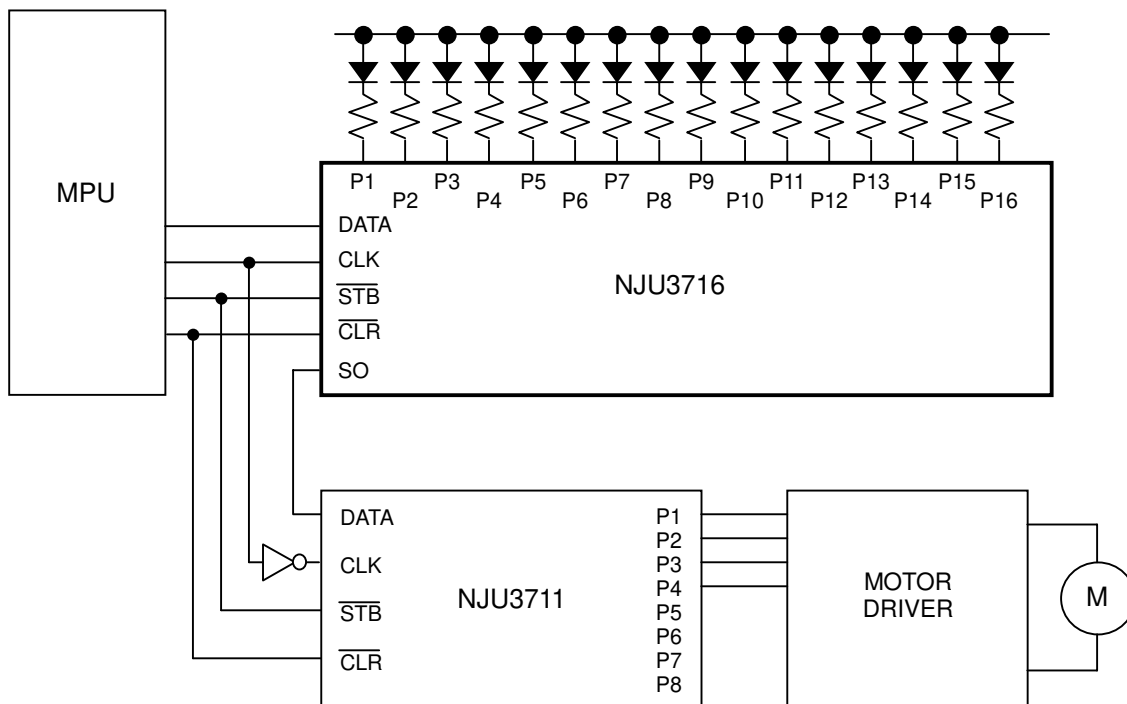

**[CAUTION]**  
 The specifications on this databook are only given for information, without any guarantee as regards either mistakes or omissions. The application circuits in this databook are described only to show representative usages of the product and not intended for the guarantee or permission of any right including the industrial rights.