



Chipsmall Limited consists of a professional team with an average of over 10 year of expertise in the distribution of electronic components. Based in Hongkong, we have already established firm and mutual-benefit business relationships with customers from,Europe,America and south Asia,supplying obsolete and hard-to-find components to meet their specific needs.

With the principle of "Quality Parts,Customers Priority,Honest Operation,and Considerate Service",our business mainly focus on the distribution of electronic components. Line cards we deal with include Microchip,ALPS,ROHM,Xilinx,Pulse,ON,Everlight and Freescale. Main products comprise IC,Modules,Potentiometer,IC Socket,Relay,Connector.Our parts cover such applications as commercial,industrial, and automotives areas.

We are looking forward to setting up business relationship with you and hope to provide you with the best service and solution. Let us make a better world for our industry!



Contact us

Tel: +86-755-8981 8866 Fax: +86-755-8427 6832

Email & Skype: info@chipsmall.com Web: www.chipsmall.com

Address: A1208, Overseas Decoration Building, #122 Zhenhua RD., Futian, Shenzhen, China



High Efficiency White LED Driver

■ GENERAL DESCRIPTION

The **NJU6050** is a high-efficiency white LED driver. It contains a high-efficiency step-up DC/DC converter and an output driver. The IC ensures a 28V maximum capacity which allows series connection of 8 white LEDs with a constant current so that the LED currents are identical for uniform brightness.

The high frequency of the step-up converter permits the use of small, low-profile inductors and capacitors to minimize the footprint in space-conscious applications. And additional features are a low operating voltage of 2.5V and the small package SOT-23 (MTP-5).

All of these benefits make the **NJU6050** suitable for the battery-powered portable applications such as a cellular phone, a camcorder, PDA, etc.

■ PACKAGE OUTLINE



■ FEATURES

- Drives Up to 8 White LEDs in Series
 $V_{SW} = 28V, I_{OUT} = 20mA$
- Uses Small Inductor and Capacitors
- 2.5V to 6.5V Operating Voltage for Step-up Circuits (V_{DD})
- CMOS Technology
- Package : SOT-23 5 pin (MTP-5)

■ PIN CONFIGURATION (TOP VIEW)

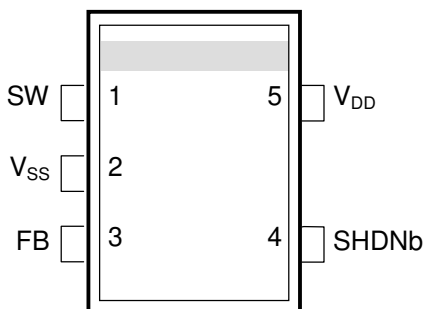

PIN DESCRIPTIONS

No.	SYMBOL	TYPE	DESCRIPTION
1	SW	Input	Switch Terminal
2	V _{SS}	Power	Ground Terminal
3	FB	Input	Feedback Terminal
4	SHDNb	Input	Shutdown Terminal Active "L" "L" : Shutdown "H" : Normal Operation
5	V _{DD}	Power	Power Supply terminal

BLOCK DIAGRAM

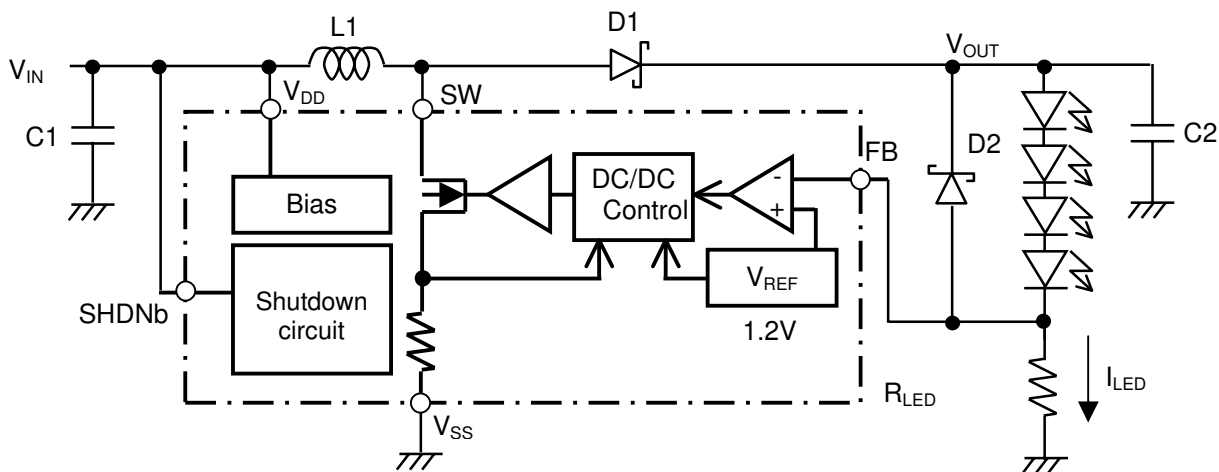

FUNCTIONAL DESCRIPTIONS

(1) LED Current Control and Resistor R_{LED} Selection

The NJU6050 incorporates the LED current control to regulate the LED current (I_{LED}), which is programmed by the feedback resistor (R_{LED}) connected between the FB and the V_{SS} terminals. The reference voltage V_{REF} is internally regulated to 1.2V typical and connected to the positive input of the built-in comparator. Formula (1) is used to choose the value of the R_{LED} , as shown below.

$$R_{LED} = \frac{V_{REF}}{I_{LED}} \quad \text{--- Formula (1)}$$

$$V_{REF} = 1.2V (typ.)$$

The I_{LED} is the constant current programmed by the R_{LED} . When the feedback voltage on the FB terminal reaches above the reference voltage V_{REF} (i.e., I_{LED} is above the level programmed by R_{LED}), the output capacitor C2 delivers the I_{LED} . Once the feedback voltage drops below the reference voltage (i.e., I_{LED} drops below the level programmed by the R_{LED}), the MOS switch is turned on, then the current of the inductor L1 begins increasing. When the switch current reaches 350mA, the MOS switch is turned off, then the L1 delivers current to the output through the diode D1 as the inductor current drops. After that, the MOS switch is turned on again and the switch current increases up to 350mA. This switching cycle continues until the I_{LED} reaches the level programmed by the R_{LED} , then the I_{LED} current is maintained constant.

(2) Inductor Selection

The following equation gives the optimum inductor value:

$$L = \frac{V_{OUT} - V_{IN(MIN)} + V_D}{I_{CL}} t_{OFF} \quad \text{Formula (2)}$$

V_D : Schottky diode Voltage

I_{CL} : Switch current limit

The power supply voltage V_{IN} may fluctuate in battery-powered applications. For this reason, the minimum voltage should be applied to the V_{IN} in Formula (2).

The **NJU6050** has about 100ns of delay time (T_{DELAY}), which is defined as the period from the reach of the current limit 350mA to the MOS-switch-off. The T_{DELAY} may cause an overshoot-inductor-current, which is called the peak current $I_{L,PEAK}$, and calculated by Formula (3). Therefore, it is recommended that an inductor with a rating twice of the $I_{L,PEAK}$ and a low DCR (DC resistance) be used for high efficiency.

$$I_{L,PEAK} = I_{CL} + \frac{V_{IN(MAX)} + V_{DS}}{L} t_{DELAY} \quad \text{Formula (3)}$$

V_{DS} : Drain-Source voltage of MOS switch ($=I_{LIMIT} \cdot R_{ON}$)

$V_{IN(MAX)}$: Maximum of V_{IN} Voltage

(3) Diode Selection

A schottky diode with a low forward-voltage-drop and a fast switching-speed is ideal for the D1. And the D1 must have a rating greater than the output voltage and output current in the system.

(4) Capacitor Selection

A low ESR (Equivalent Series Resistance) capacitor should be used as the output capacitor C2 to minimize output ripples. A multi-layer ceramic capacitor is the best selection for the **NJU6050** application because of not only the low ESR but its small package. A ceramic capacitor is also recommended for the input decoupling-capacitor C1, and should be placed as close to the **NJU6050** as possible.

(5) Open-circuit Protection

The zener diode D2 works as an open-circuit protection. When the LED is disconnected from the circuit, the feedback voltage on the FB terminal is pulled down to 0V, which makes the switching frequency maximum. Without the diode D2, the SW voltage exceeds the absolute maximum rating, and this voltage stress may cause a permanent damage to the IC.

The zener voltage must be greater than the maximum forward-voltage of the LED string.

NJU6050

■ ABSOLUTE MAXIMUM RATINGS

Ta=25°C

PARAMETERS	SYMBOL	CONDITIONS	RATINGS	UNIT
VDD Power Supply	V _{DD}		-0.3 to +7.0	V
SHDNb Terminal Voltage	V _{SHDNb}	SHDNb terminal	-0.3 to +7.0	V
SW Terminal Voltage	V _{SW}	SW terminal	-0.3 to +30.0	V
FB Terminal Voltage	V _{FB}	FB terminal	-0.3 to V _{DD}	V
Power Dissipation	PD	MTP-5	200	mW
Operating Temperature	T _{opr}		-40 to +85	°C
Storage Temperature	T _{stg}		-65 to +150	°C

Note1) All voltages are relative to V_{SS} = 0V reference.

Note2) Do not exceed the absolute maximum ratings, otherwise the stress may cause a permanent damage to the IC. It is also recommended that the IC be used in the range specified in the DC electrical characteristics, or the electrical stress may cause malfunctions and impact on the reliability.

■ DC ELECTRICAL CHARACTERISTICS

(V_{DD}=3.6V, V_{SHDNb}=3.6V, V_{SS}=0V, Ta=25°C)

PARAMETERS	SYMBOL	CONDITIONS	MIN.	TYP.	MAX.	Unit
V _{DD} Power Supply	V _{DD}		2.5		6.5	V
Quiescent Current	I _{STBY1}	No switching		20	30	μA
	I _{STBY2}	V _{SHDNb} =0V		0.1	1	
FB Comparator Trip point	V _{F_{BP}}		1.18	1.2	1.22	V
Output Voltage Line Regulation	V _K	2.5V < V _{IN} < 6.5V		-0.05		%/V
FB Terminal Bias Current	I _{FB}	V _{FB} = 1.2V		30.0	80.0	nA
Switch Off Time	t _{OFF}	V _{FB} > 1.0V		500		ns
		V _{FB} < 0.6V		1.6		μs
Switch VDS(ON)	V _{DS}	I _{SW} =300mA		250	350	mV
Switch Current Limit	I _{CL}		300	350	400	mA
SHDNb Terminal Current	I _{SHDNb}			0.1	1.0	μA
SHDNb Input Voltage High	V _{SHDNH}		0.9			V
SHDNb Input Voltage Low	V _{SHDNL}				0.25	V
Switch Leakage Current	I _L	Switch Off, V _{SW} =28V		0.01	5.0	μA

TYPICAL PERFORMANCE

($V_{DD}=3.6V$, $V_{SHDNb}=3.6V$, $V_{SS}=0V$, $L=10\mu H$, $T_a=25^\circ C$)

Output Voltage vs. Input Voltage

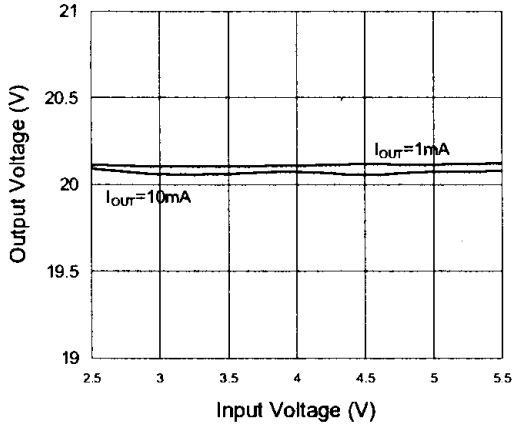

Output Voltage vs. Load Current

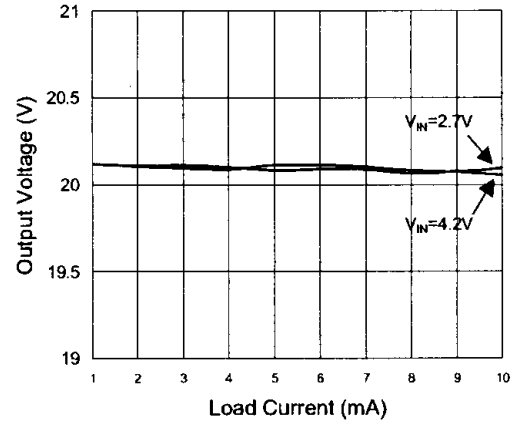

Efficiency vs. Load Current

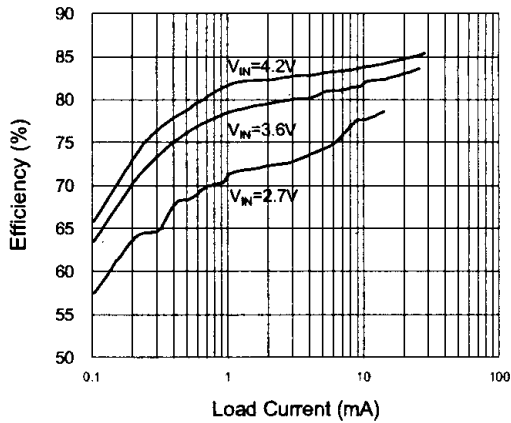

Quiescent Current vs. Temperature

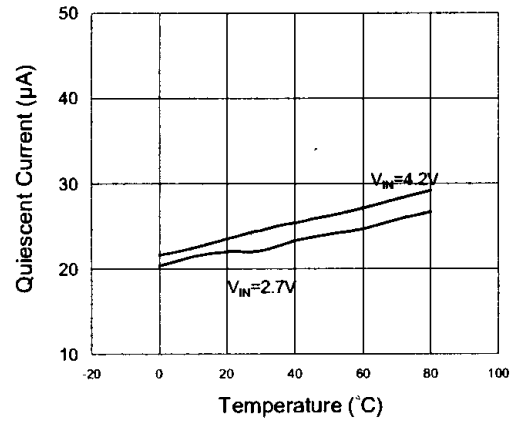

$V_{DS(ON)}$ vs. Temperature

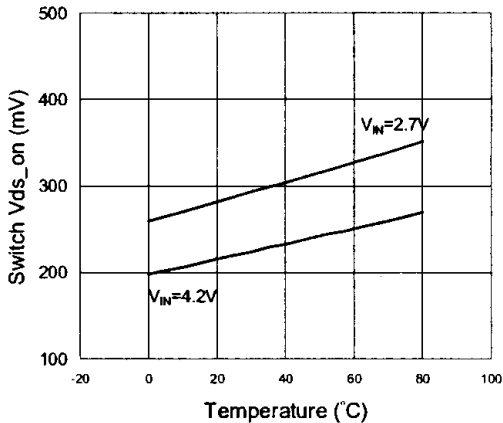

Feedback Voltage vs. Temperature

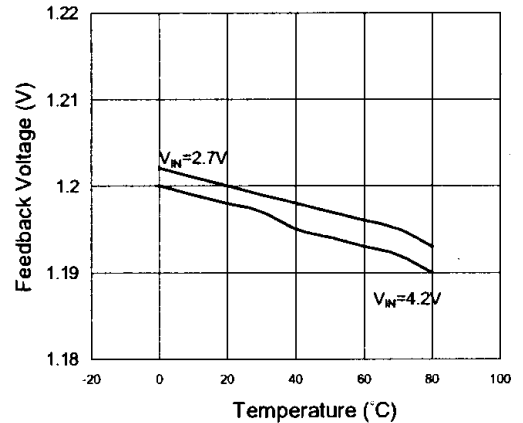

($V_{DD}=3.6V$, $V_{SHDNb}=3.6V$, $V_{SS}=0V$, $L=10\mu H$, $T_a=25^\circ C$)

FB Bias Current vs. Temperature

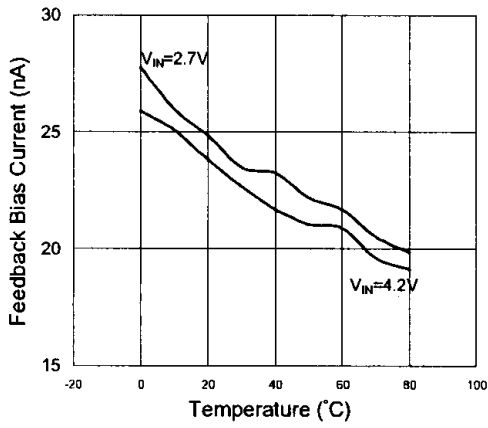

Switch Current Limit vs. Temperature

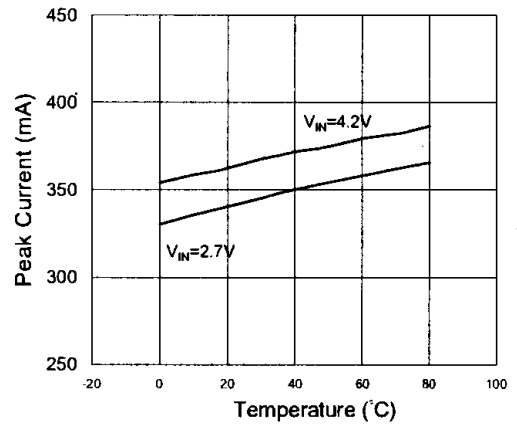

Line Transient

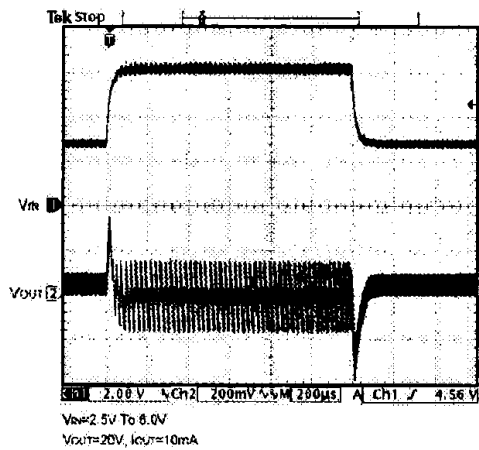

Load Transient

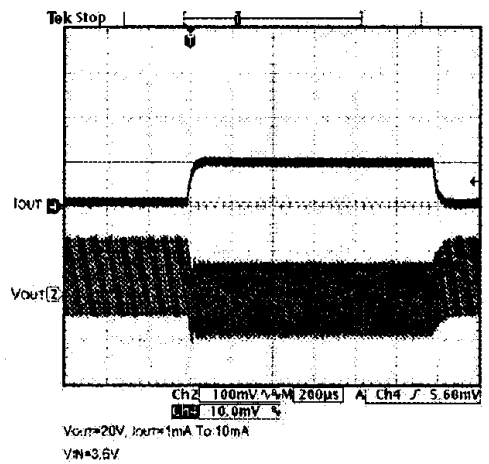

■ TYPICAL APPLICATION CIRCUITS

(1) 8 white LEDs

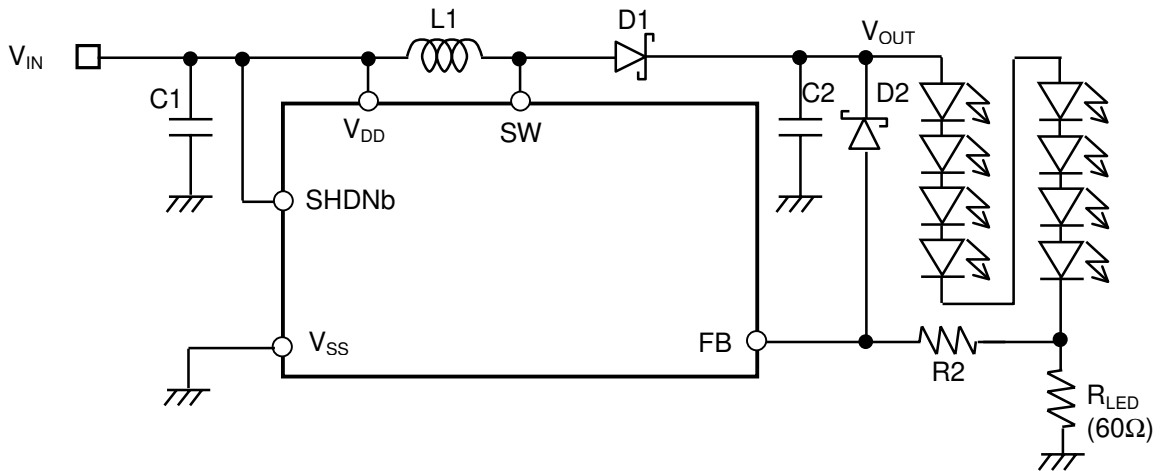

(2) 8 white LEDs & Dimming control by external PWM signal

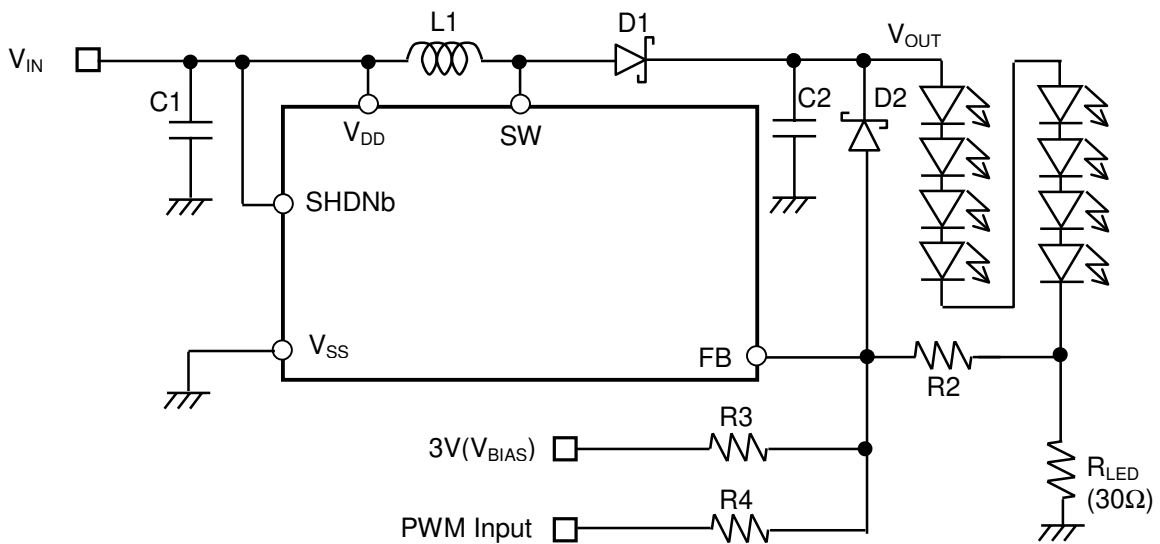

Referential List of External Components

Component	Supplier / Parts Number	Qty	Value
IC1	LED Driver IC	NJRC / NJU6050F	1
L1	Inductor	TDK / VLF3010AT-100MR49	1
D1	Schottky Diode	ROHM / RB160M-30	1
D2	Zener Diode	ROHM / UDZS27B	1
C1	Ceramic Capacitor	TAIYO YUDEN / JMK107 BJ475MA	1
C2	Ceramic Capacitor	TAIYO YUDEN / GMK316BJ105	1
R _{LED} (R1)	Chip Resistor	Standard	30Ω
R2	Chip Resistor	Standard	120kΩ
R3	Chip Resistor	Standard	240kΩ
R4	Chip Resistor	Standard	620kΩ
LED1 to 8	White LED	NICHIA / NSCW215T	8

MEMO

[CAUTION]

The specifications on this databook are only given for information , without any guarantee as regards either mistakes or omissions. The application circuits in this databook are described only to show representative usages of the product and not intended for the guarantee or permission of any right including the industrial rights.