



Chipsmall Limited consists of a professional team with an average of over 10 year of expertise in the distribution of electronic components. Based in Hongkong, we have already established firm and mutual-benefit business relationships with customers from,Europe,America and south Asia,supplying obsolete and hard-to-find components to meet their specific needs.

With the principle of “Quality Parts,Customers Priority,Honest Operation,and Considerate Service”,our business mainly focus on the distribution of electronic components. Line cards we deal with include Microchip,ALPS,ROHM,Xilinx,Pulse,ON,Everlight and Freescale. Main products comprise IC,Modules,Potentiometer,IC Socket,Relay,Connector.Our parts cover such applications as commercial,industrial, and automotives areas.

We are looking forward to setting up business relationship with you and hope to provide you with the best service and solution. Let us make a better world for our industry!



## Contact us

Tel: +86-755-8981 8866 Fax: +86-755-8427 6832

Email & Skype: info@chipsmall.com Web: www.chipsmall.com

Address: A1208, Overseas Decoration Building, #122 Zhenhua RD., Futian, Shenzhen, China



## Full Color LED Controller Driver with PWM Control

### ■ GENERAL DESCRIPTION

The **NJU6060** is an RGB LED driver with PWM control. It contains PWM (pulse width modulation) controller, LED drivers, 8-bit serial interface, etc. Each of the R (red), G (green) and B (blue) outputs produces 32 levels individually so that the RGB LED emits 32,768 colors (32 x 32 x 32).

It requires only four external components such as three resistors for LED current adjustment and the one for oscillation, which enables the **NJU6060** to save PCB space. The **NJU6060** is suited for a large number of applications such as cellular phones, car stereo sets, household appliances, illumination equipment, etc.

### ■ FEATURES

- Controls the 3-color LED Separately (ILED=10mA x 3 outputs)
- Built-in PWM Luminance Control (32 steps x 3)
- Built-in 8bit serial Interface Circuit
- Built-in Oscillation Circuit
- Operating Voltage for Step-up Circuits : 2.4V to 5.5V
- Package : SSOP-10
- CMOS Technology

### ■ PACKAGE OUTLINE

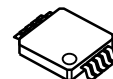

**NJU6060V**

# NJU6060

## ■ PIN CONNECTIONS (TOP VIEW)

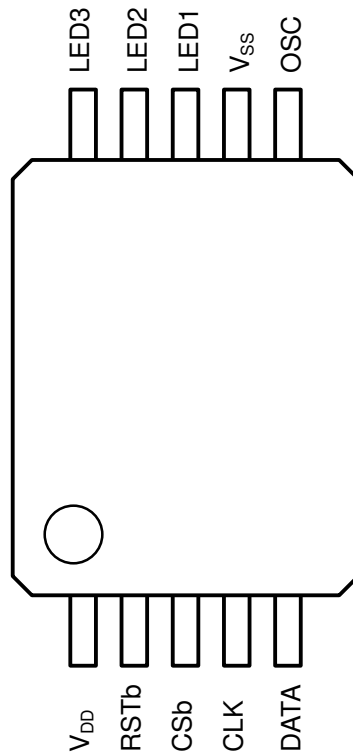

## ■ PIN DESCRIPTIONS

No.	PIN NAME	TYPE	DESCRIPTIONS
1	V <sub>DD</sub>	Power	V <sub>DD</sub> Power Supply terminal
2	RSTb	Input	Reset terminal - Active "L".
3	CSb	Input	Chip Select terminal The serial data is fixed on the rising edge of CSb clock.
4	CLK	Input	Shift Clock terminal
5	DATA	Input	Serial Data terminal
6	OSC	Input	Oscillating terminal External resistor connecting
7	V <sub>SS</sub>	Power	Ground terminal
8	LED1	Output	LED Connect terminals (Open drain output) Output level are 32 steps PWM by instruction control. Connecting cathode of LED.
9	LED2	Output	
10	LED3	Output	

## ■ BLOCK DIAGRAM

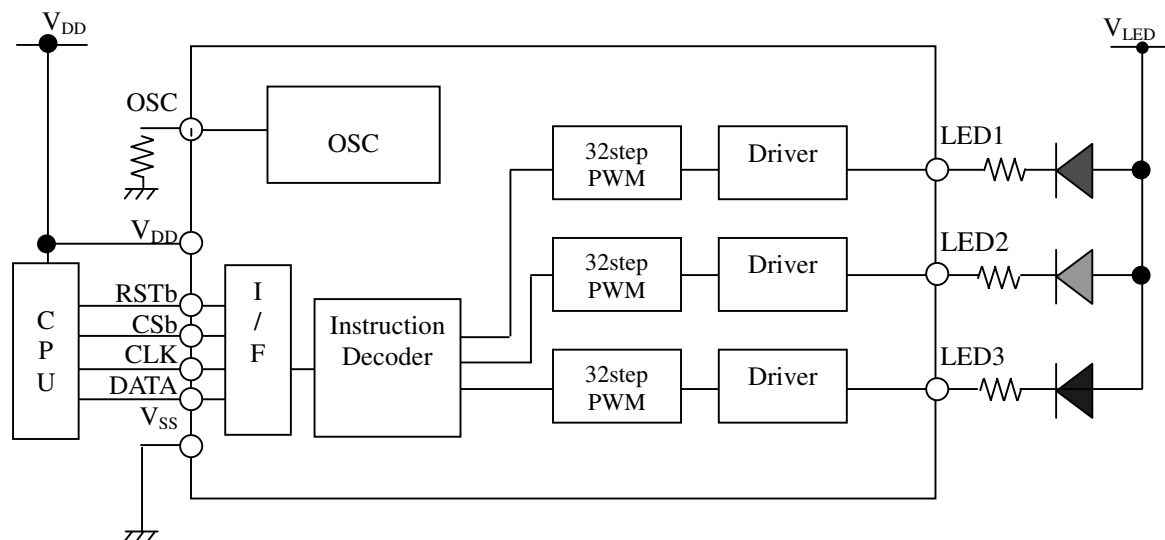

## ■ FUNCTIONAL DESCRIPTIONS

### (1) Description for each blocks

#### (1-1) PWM Luminance Control

The **NJU6060** incorporates three channel of 32 steps PWM Luminance Control circuits. 32 steps of Luminance Control by setting up DUTY. The relation between a register and DUTY is shown below:

REGISTER	DUTY	REGISTER	DUTY	REGISTER	DUTY	REGISTER	DUTY
0,0,0,0,0	1/32	0,1,0,0,0	9/32	1,0,0,0,0	17/32	1,1,0,0,0	25/32
0,0,0,0,1	2/32	0,1,0,0,1	10/32	1,0,0,0,1	18/32	1,1,0,0,1	26/32
0,0,0,1,0	3/32	0,1,0,1,0	11/32	1,0,0,1,0	19/32	1,1,0,1,0	27/32
0,0,0,1,1	4/32	0,1,0,1,1	12/32	1,0,0,1,1	20/32	1,1,0,1,1	28/32
0,0,1,0,0	5/32	0,1,1,0,0	13/32	1,0,1,0,0	21/32	1,1,1,0,0	29/32
0,0,1,0,1	6/32	0,1,1,0,1	14/32	1,0,1,0,1	22/32	1,1,1,0,1	30/32
0,0,1,1,0	7/32	0,1,1,1,0	15/32	1,0,1,1,0	23/32	1,1,1,1,0	31/32
0,0,1,1,1	8/32	0,1,1,1,1	16/32	1,0,1,1,1	24/32	1,1,1,1,1	32/32

#### (1-2) Oscillator

The **NJU6060** Oscillation circuit is generated clock which generates PWM by connecting external resistor.

The oscillation circuit with the external register generate the clock for PWM. The PWM frequency ( $f_{PWM}$ ) is finely adjusted by value of the external register. In addition, the ON/OFF of oscillation circuit is controlled by the instruction, and the current consumption is decreased when it was OFF of the oscillation circuit.

If PWM was high when the oscillation circuit became OFF, the situation of PWM was kept. Input OFF command of the output port.

## (2) Instructions

3 line type serial interface using a setup of PWM data, ON/OFF of Light Emitting Diode, etc. are made.

The input data and latched at rising edge of chip shift clock (CLK) and the 8-bit data are fetched into the NJU6060 at the rising edge of chip select (CS). The data to input is MSB first.

Table.1 shows the instruction codes of the NJU6060.

Table 1. Instruction Code

Instruction	Code								Discription
	D7	D6	D5	D4	D3	D2	D1	D0	
LED1 PWM Data Set	0	0	0	D	D	D	D	D	5-bit PWM data is set.
LED2 PWM Data Set	0	0	1	D	D	D	D	D	5-bit PWM data is set.
LED3 PWM Data Set	0	1	0	D	D	D	D	D	5-bit PWM data is set.
PWM Frequency set / OSC ON/OFF /Output port ON/OFF	0	1	1	$f_{PWM}$	OSC	LED1	LED2	LED3	$f_{PWM}$ 0:(fosc/2)/32 1:(fosc/2)/64 OSC 0:OFF 1:ON LED1 to 3 0:OFF 1:ON
LED1 PWM Phase set	1	0	0	*	*	*	Phase value		0,0: Same phase 0,1: 4-step shift 1,0: 8-step shift 1,1: 16-step shift
LED2 PWM Phase set	1	0	1	*	*	*	Phase value		
LED3 PWM Phase set	1	1	0	*	*	*	Phase value		
Test	1	1	1	Test Data				Inhibited command	

\* : Don't Care

Note) The "PWM data set", the "PWM Frequency set" and the "PWM phase set" commands are executed, asynchronously to the PWM counter, thus the user's command setting is executed after execution time, which is about  $128/f_{osc}$  if  $\{f_{PWM}=(f_{osc}/2)/2\}$  is set up. During that execution time, the IC may execute an unexpected setting. For this reason, it is recommended to make sure actual performance is the user's practical application.

### (2-1) Explanation of instruction code

#### (a) LED1 to 3 PWM Data Set

This instruction set the PWM luminance control Duty data. It sets up for every LED port.

#### LED1 PWM Data Set

D7	D6	D5	D4	D3	D2	D1	D0
0	0	0	D	D	D	D	D

#### LED2 PWM Data Set

D7	D6	D5	D4	D3	D2	D1	D0
0	0	1	D	D	D	D	D

#### LED3 PWM Data Set

D7	D6	D5	D4	D3	D2	D1	D0
0	1	0	D	D	D	D	D

D :DUTY

0,0,0,0,0 to 1,1,1,1,1

(b) PWM Frequency set / OSC ON/OFF / Output port ON/OFF  
 This instruction set the PWM Frequency, Oscillator ON/OFF and Output port ON/OFF.

PWM Frequency set / OSC ON/OFF / Output port ON/OFF

D <sub>7</sub>	D <sub>6</sub>	D <sub>5</sub>	D <sub>4</sub>	D <sub>3</sub>	D <sub>2</sub>	D <sub>1</sub>	D <sub>0</sub>
0	1	1	f <sub>PWM</sub>	OSC	LED 1	LED 2	LED 3

PWM Frequency set

f<sub>PWM</sub>            0 : fsys / 32 frequency(Default)  
                      1 : fsys / 64 frequency  
                      (fsys : System clock = fosc / 2)

OSC ON/OFF

OSC            0 : Oscillator OFF(Default)  
                      1 : Oscillator ON

Output port ON/OFF

LED1 to 3       0 : Output port OFF(Default)  
                      1 : Output port ON  
                      It sets up for every LED port.

(c) LED1 to 3 PWM Phase set  
 This instruction set the PWM waveform Phase of output LED ports.

LED1 PWM Phase set

D <sub>7</sub>	D <sub>6</sub>	D <sub>5</sub>	D <sub>4</sub>	D <sub>3</sub>	D <sub>2</sub>	D <sub>1</sub>	D <sub>0</sub>
1	0	0	*	*	*	Phase	

\*: Don't Care

LED2 PWM Phase set

D <sub>7</sub>	D <sub>6</sub>	D <sub>5</sub>	D <sub>4</sub>	D <sub>3</sub>	D <sub>2</sub>	D <sub>1</sub>	D <sub>0</sub>
1	0	1	*	*	*	Phase	

\*: Don't Care

LED3 PWM Phase set

D <sub>7</sub>	D <sub>6</sub>	D <sub>5</sub>	D <sub>4</sub>	D <sub>3</sub>	D <sub>2</sub>	D <sub>1</sub>	D <sub>0</sub>
1	1	0	*	*	*	Phase	

\*: Don't Care

D <sub>1</sub>	D <sub>0</sub>	Shift Phase Value
0	0	Same Phase
0	1	4-step shift
1	0	8-step shift
1	1	16-step shift

Example ) Set Output PWM waveform of LED1 to LED3 terminal, shown below:

- LED1 PWM Phase set  $D_1=0, D_0=0$
- LED2 PWM Phase set  $D_1=1, D_0=0$
- LED3 PWM Phase set  $D_1=1, D_0=1$
- PWM Frequency set / OSC ON/OFF / Output port ON/OFF  $D_4=0, D_3=1, D_2=1, D_1=1, D_0=1$
- LED1 to 3 PWM Data Set  
 $(PWM_4, PWM_3, PWM_2, PWM_1, PWM_0) = (1, 0, 0, 0, 0)$

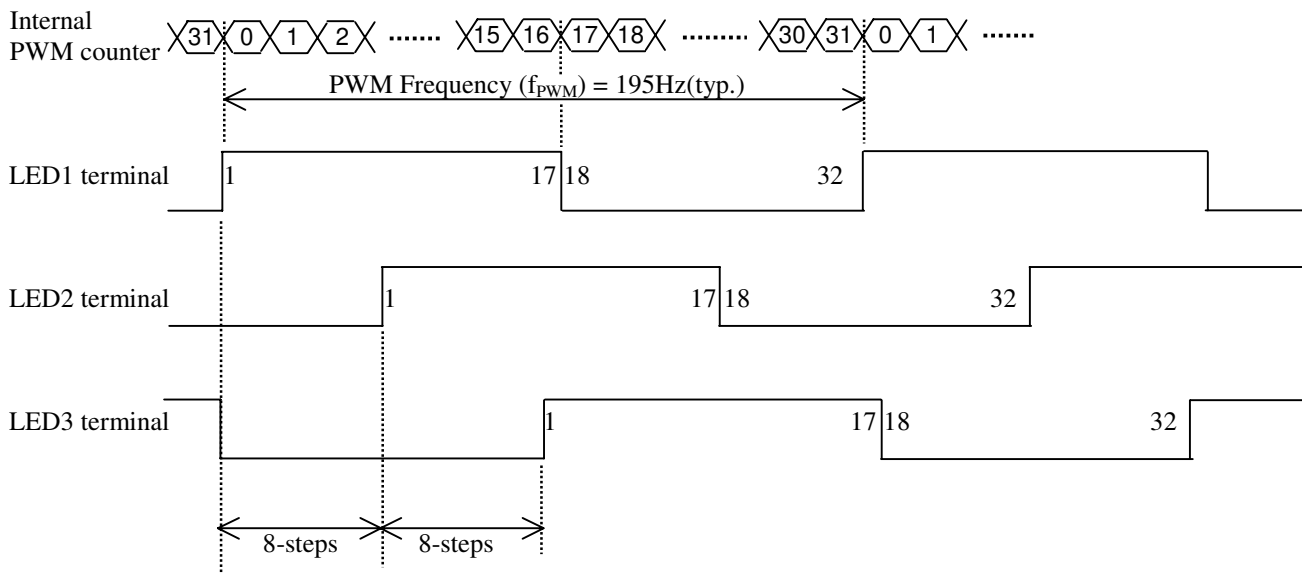

#### (d) Maker Testing

This instruction is using for device testing mode (only for maker).

If it's absolute necessary in the user's command sequence, the only one command data (1,1,1,0,0,0,0,0) to release the test mode can be accepted.

D <sub>7</sub>	D <sub>6</sub>	D <sub>5</sub>	D <sub>4</sub>	D <sub>3</sub>	D <sub>2</sub>	D <sub>1</sub>	D <sub>0</sub>
1	1	1	Test Data				

### (3) Serial Interface

The NJU6060 interface with MPU by Serial Interface, control for LED.

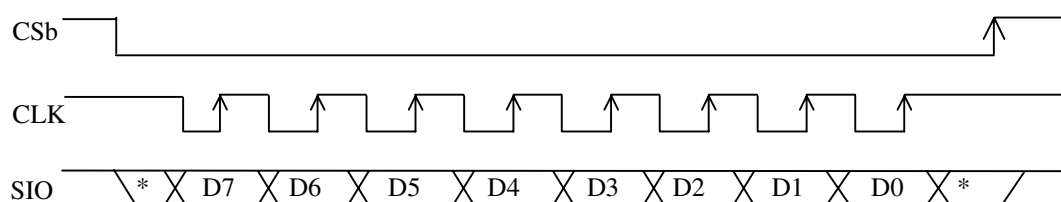

Note1) Data is not concerned with the signal of CSb but is read into the internal shift register by the rising edge of CLK.

Note2) The contents of a shift register are read into the internal instruction decoder by the rising edge of CSb.

note3) An instruction and data should surely input 8 bits. In case of entering over than 8 bits data, valid data is last 8 bits data.

### (4) Reset Circuit

Reset Circuit initializes the LSI to the following status by using of the more 1 $\mu$ s reset signal into the RES terminal

Reset status using the RES terminal

1, $f_{PWM}$	0: ( $f_{osc}/2$ )/32
2, OSC	0: Oscillation OFF
3, LED1 to 3	0: OFF
4, Phase	0,0: Same Phase
5, PWM data	0,0,0,0: 1/32



## ■ ABSOLUTE MAXIMUM RATINGS

Ta=25°C

PARAMETERS	SYMBOL	CONDITIONS	RATINGS	UNIT
VDD Power Supply	V <sub>DD</sub>	VDD terminal	-0.3 to +6.0	V
Driver Off Break Down Voltage	V <sub>offmax</sub>	LED1, LED2, LED3 terminals	7.0	V
Driver On Break Down Voltage	V <sub>onmax</sub>	LED1, LED2, LED3 terminals	5.5	V
Input Voltage	V <sub>IN1</sub>	CSb, DATA, CLK, RSTb, OSC Terminals	-0.3 to V <sub>DD</sub> +0.3	V
Power Dissipation	P <sub>dmax</sub>	Ta=25°C	250	mW
Operating Temperature	T <sub>opr</sub>		-40 to +85	°C
Storage Temperature	T <sub>stg</sub>		-55 to +125	°C

Note1) V<sub>SS</sub> = 0V to all conditions

Note2) If the LSI was used out of the absolute maximum ratings, LSI is damaged completely and the reliability become poor. The LSI is used on the electrical characteristics is recommended strongly for normal operation.

## DC ELECTRICAL CHARACTERISTICS

$V_{DD}=2.4$  to  $5.5V$ ,  $T_a=-40$  to  $85^{\circ}C$

PARAMETERS	SYMBOL	CONDITIONS	MIN.	TYP.	MAX.	Unit
$V_{DD}$ Power Supply	$V_{DD}$		2.4		5.5	V
Input "H" Level Voltage	$V_{IH}$	RSTb, CSb, CLK, DATA	$0.8V_{DD}$		$V_{DD}$	V
Input "L" Level Voltage	$V_{IL}$	RSTb, CSb, CLK, DATA	0		$0.2V_{DD}$	V
Input "H" Level Current	$I_{IH}$	RSTb, CSb, CLK, DATA, $V_{IN}=V_{DD}$			5.0	$\mu A$
Input "L" Level Current	$I_{IL}$	RSTb, CSb, CLK, DATA, $V_{IN}=0V$	-5.0			$\mu A$
Output Off Leak Current	$I_{OFFH}$	LED1, LED2, LED3: $V_O=5.5V$ , Output OFF			6.0	$\mu A$
Output "L" Level Voltage	$V_{OL}$	LED1, LED2, LED3, $I_O=10mA$			0.5	V
Oscillation Frequency	$f_{OSC}$	$V_{DD}=3V$ , $R_{OSC}=910k\Omega$ , $T_a=25^{\circ}C$	10.23	12.48	14.72	kHz
Reset "L" Level Pulse Width	$t_{RW}$	RSTb	1.0			$\mu s$
Operating Current	$I_{DD}$	$V_{DD}=3V$ , PWM DUTY: 17/32, Output terminal open, $R_{OSC}=910k\Omega$ , $T_a=25^{\circ}C$		6.0	12.0	$\mu A$

Note1): Input Terminal Structure

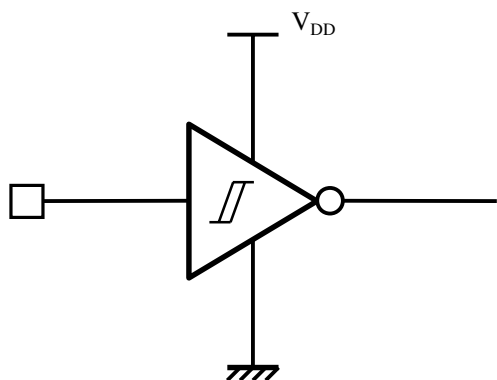

RSTb, CSb, CLK, DATA terminals

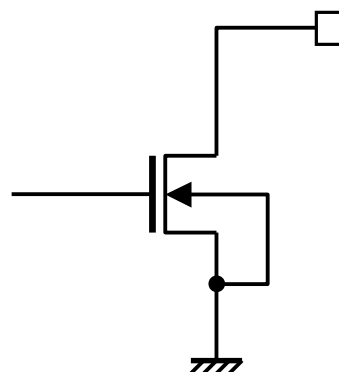

LED1, LED2, LED3 terminals

## Relation between oscillation frequency and LCD frame frequency

Set Output PWM waveform of LED1 to LED3 terminal, shown below:

- LED1 PWM Phase set  $D_1=0, D_0=0$
- LED2 PWM Phase set  $D_1=1, D_0=0$
- LED3 PWM Phase set  $D_1=1, D_0=1$
- PWM Frequency set / OSC ON/OFF / Output port ON/OFF  $D_4=0, D_3=1, D_2=1, D_1=1, D_0=1$
- LED1 to 3 PWM Data Set  $(PWM_4, PWM_3, PWM_2, PWM_1, PWM_0) = (1, 0, 0, 0, 0)$

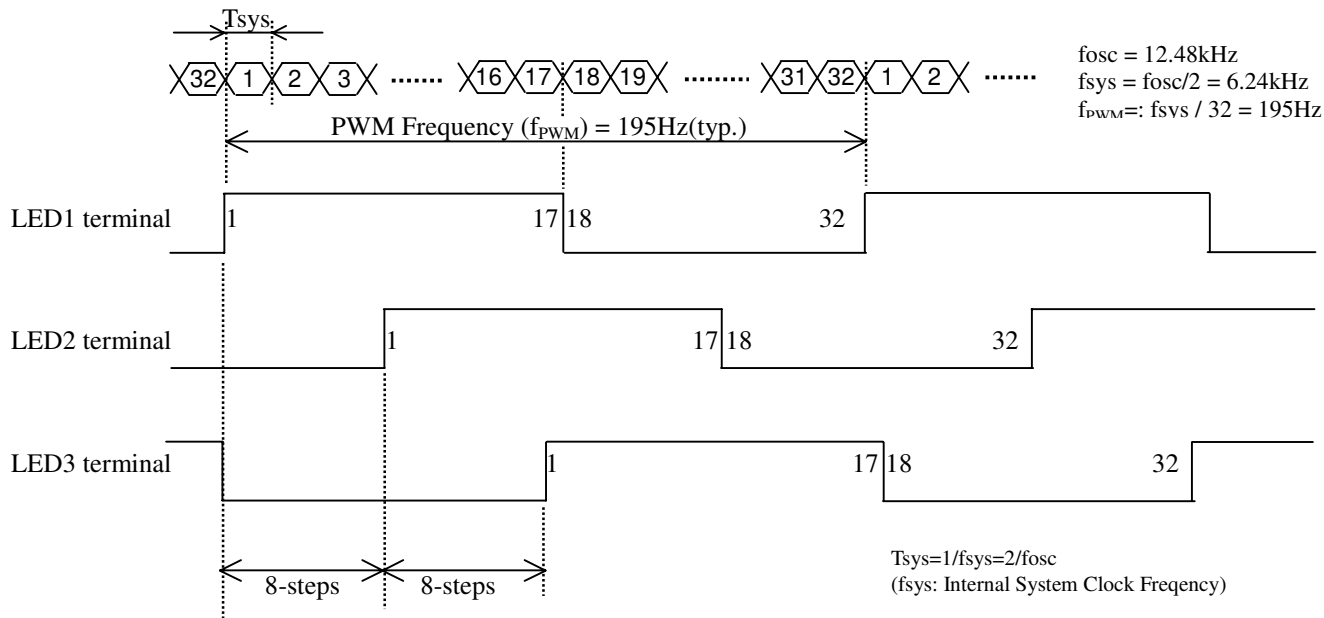

Set Output PWM waveform of LED1 to LED3 terminal, shown below:

- LED1 PWM Phase set  $D_1=0, D_0=0$
- LED2 PWM Phase set  $D_1=1, D_0=0$
- LED3 PWM Phase set  $D_1=1, D_0=1$
- PWM Frequency set / OSC ON/OFF / Output port ON/OFF  $D_4=1, D_3=1, D_2=1, D_1=1, D_0=1$
- LED1 to 3 PWM Data Set  $(PWM_4, PWM_3, PWM_2, PWM_1, PWM_0) = (1, 0, 0, 0, 0)$

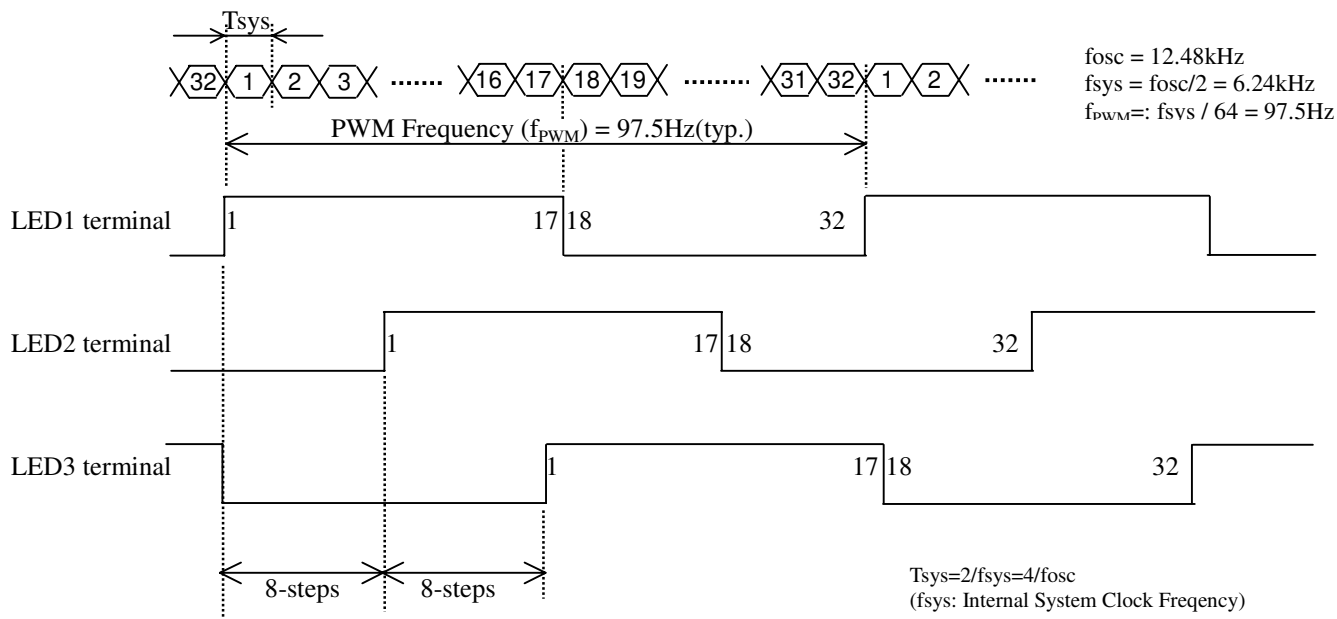

## ■ AC ELECTRICAL CHARACTERISTICS

VDD=2.4 to 5.5V, Ta=-40 to 85°C

PARAMETERS	SYMBOL	Terminal	MIN.	TYP.	MAX.	UNIT
“L” Level CLK Clock Width	$t_{WCLL}$	CLK	160			ns
“H” Level CLK Clock Width	$t_{WCLH}$	CLK	160			ns
Data Set-Up Time	$t_{DS}$	CLK, DATA	150			ns
Data Hold Time	$t_{DH}$	CLK, DATA	150			ns
CSb Set-Up Time	$t_{CS}$	CSb, CLK	160			ns
CSb Hold Time	$t_{CH}$	CSb, CLK	640			ns
CLK Wait Time	$t_{WCH}$	CSb	640			ns
Rising Time	$t_r$				15	ns
Falling Time	$t_f$				15	ns

### Serial Input Timing

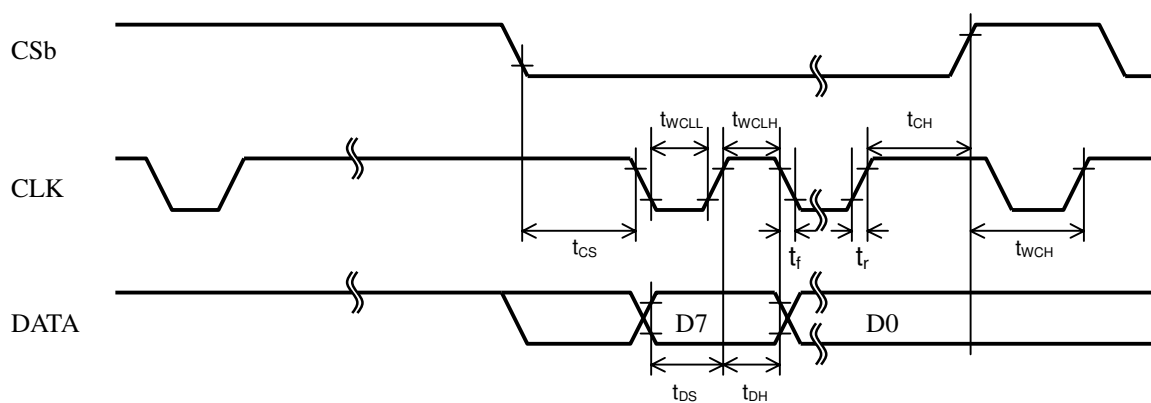

Note) All timing based on 20% and 80% of  $V_{DD}$  voltage level.

## APPLICATION CIRCUIT

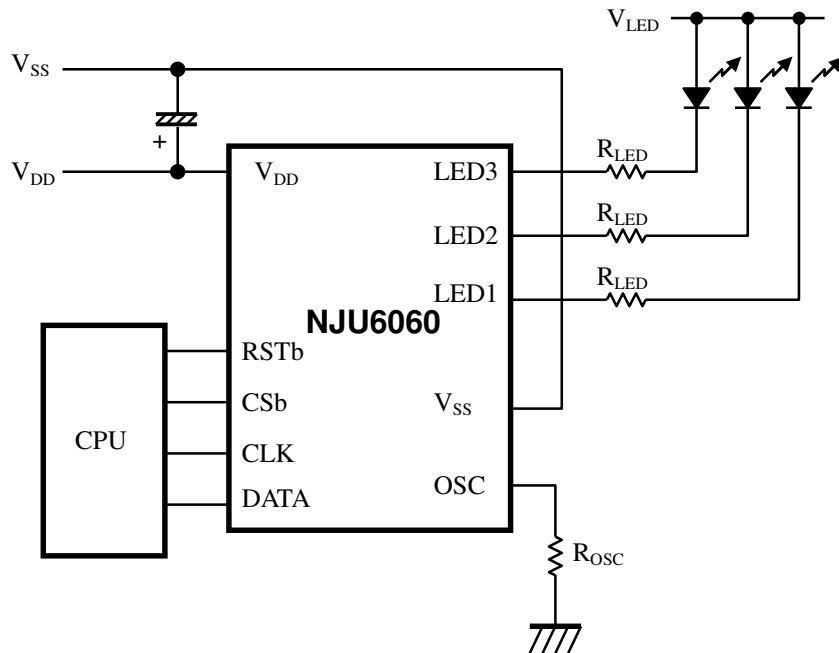

### Resistor Selection

$$R_{LED} = \frac{V_{LED} - V_F - V_{OL}}{I_{LED}}$$

- $R_{LED}$ : LED Current Control Resistor
- $V_{LED}$ : LED Voltage
- $V_F$ : LED Forward Voltage (@ $I_{LED}$ )
- $V_{OL}$ : Output "L" Level Voltage (@ $I_{LED}$ )
- $I_{LED}$ : LED Forward Current

Example)  $I_{LED} = 10\text{mA}$ ,  $V_{LED} = 5.0\text{V}$ ,  $V_F = 2.0\text{V}(@I_{LED} = 10\text{mA})$ ,  $V_{OL} = 0.5\text{V}$

$$R_{LED} = \frac{5.0\text{V} - 2.0\text{V} - 0.5\text{V}}{10\text{mA}} = 250\Omega$$

Note)

$V_F$  and  $V_{OL}$  are depended on the situation. And decide the optimum values by the actual test when  $R_{LED}$  is selected.

**[CAUTION]**

The specifications on this databook are only given for information, without any guarantee as regards either mistakes or omissions. The application circuits in this databook are described only to show representative usages of the product and not intended for the guarantee or permission of any right including the industrial rights.

The products on this databook may not be appropriate for use in certain equipment where reliability is critical or where the products may be subjected to extreme conditions. Thus, you should consult our sales office before using the products in vehicle control equipment.