



Chipsmall Limited consists of a professional team with an average of over 10 year of expertise in the distribution of electronic components. Based in Hongkong, we have already established firm and mutual-benefit business relationships with customers from,Europe,America and south Asia,supplying obsolete and hard-to-find components to meet their specific needs.

With the principle of "Quality Parts,Customers Priority,Honest Operation,and Considerate Service",our business mainly focus on the distribution of electronic components. Line cards we deal with include Microchip,ALPS,ROHM,Xilinx,Pulse,ON,Everlight and Freescale. Main products comprise IC,Modules,Potentiometer,IC Socket,Relay,Connector.Our parts cover such applications as commercial,industrial, and automotives areas.

We are looking forward to setting up business relationship with you and hope to provide you with the best service and solution. Let us make a better world for our industry!



Contact us

Tel: +86-755-8981 8866 Fax: +86-755-8427 6832

Email & Skype: info@chipsmall.com Web: www.chipsmall.com

Address: A1208, Overseas Decoration Building, #122 Zhenhua RD., Futian, Shenzhen, China



1.8V Operating Voltage 3rd Overtone Quartz Crystal Oscillator IC with Input Tolerant Function

■ GENERAL DESCRIPTION

The NJU6227 series is a C-MOS quartz crystal oscillator IC realized excellent frequency stability for 3rd Overtone (up to 160MHz) oscillation, and consists of an oscillation amplifier, a 3-state output buffer, a built-in LDO and a input tolerant circuit.

The operating voltage is from 1.62V to 3.63V (x3, x4, x5, x6: from 2.25V to 3.63V), and the LDO holds down the characteristic change of the oscillation amplifier for operating voltage variation, and has been stabilized oscillation frequency (Frequency stability $\pm 1\text{ppm}@V_{DD}\pm 10\%$).

The input tolerant circuit ensures that 0 to 3.63 V can be applied to CONT terminal without regard to the supply voltage.

The oscillation stopping current is very low stand-by mode, therefore, it is suitable for the portable items of the communication equipment and the like. The 3-state output buffer is C-MOS compatible. The NJU6227A/D version are available for driving light loads (15pF load) and NJU6227C version are available for driving heavy loads (30pF load).

■ PACKAGE OUTLINE



NJU6227xXC-V

■ FEATURES

- Maximum Oscillation Frequency 160MHz(3rd Overtone)
- Frequency Stability $\pm 1\text{ppm}@V_{DD}\pm 10\%$
- Wide Operating Voltage 1.62 to 3.63V(x3, x4, x5, x6 2.25V to 3.63V)
- Built-in LDO
- Input Tolerant Circuit 0 to 3.63V@CONT Term.
- Stand-by Function (Oscillation Stop and High-Z)
- 3-State Output Buffer
- Variable Pull-up Resistance on-Die (CONT Terminal: Pull-up resistance is large at Stand-by Function)
- Oscillation Capacitors Cg and Cd on-Die
- C-MOS Technology
- Package Outline Die/Wafer

■ BLOCK DIAGRAM

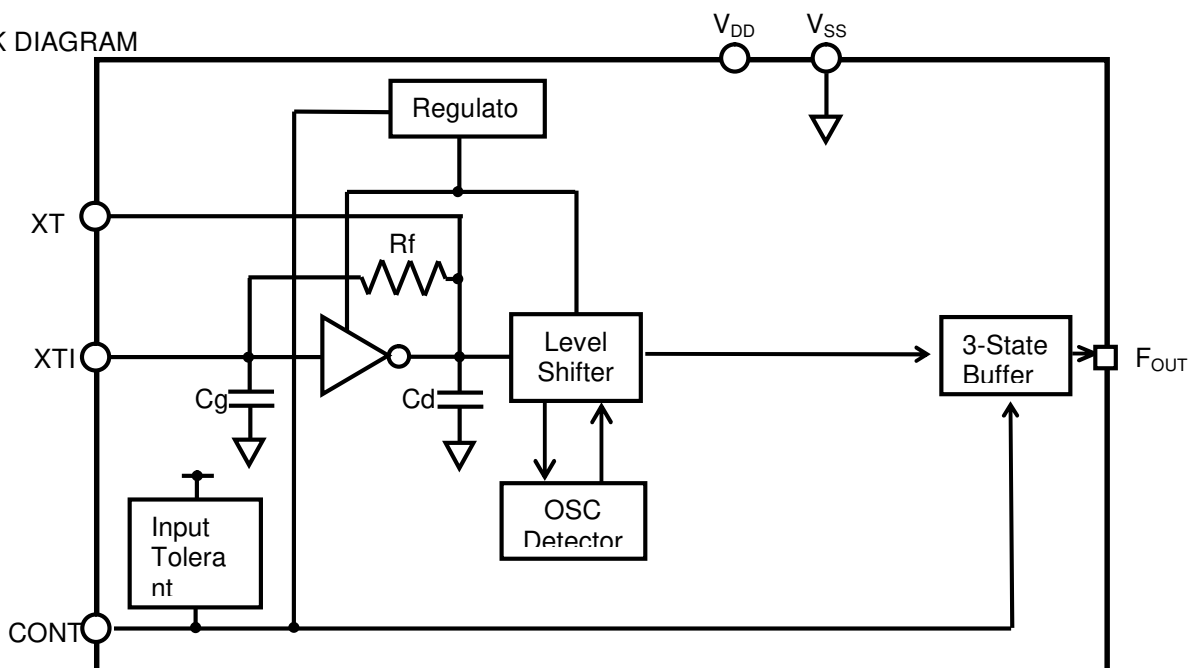

LINE-UP TABLE

Type No.	Recommended Oscillation Frequency	Version		
		Type A	Type C	Type D
NJU6227	40 to 50MHz	A1*	C1	D1
	50 to 60MHz	A2*	C2	D2
	60 to 85MHz	A3*	C3	D3
	85 to 110MHz	A4*	C4	D4
	110 to 130MHz	A5*	C5	D5
	130 to 160MHz	A6*	C6	D6

* Under development and tentative value.

PAD LOCATION

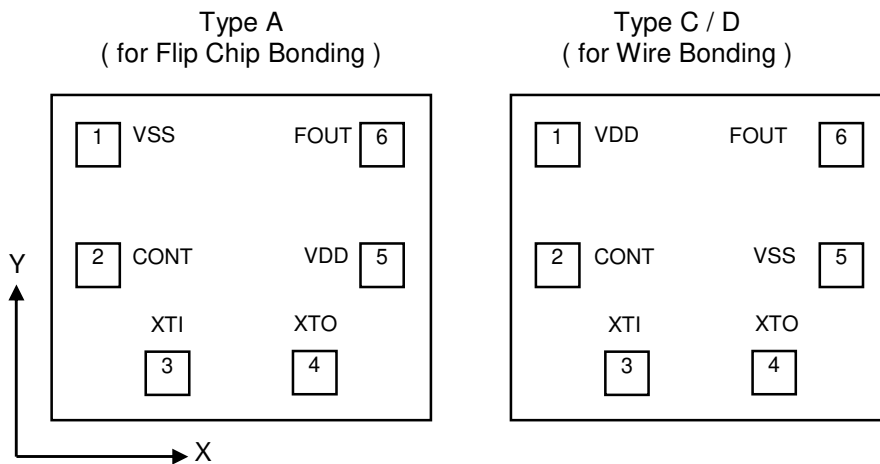

COORDINATES

	X	Y
1	-261.5	198.5
2	-261.5	-21.5
3	-146.5	-211.5
4	144.5	-211.5
5	260.5	-21.5
6	260.5	198.5

PART NUMBER

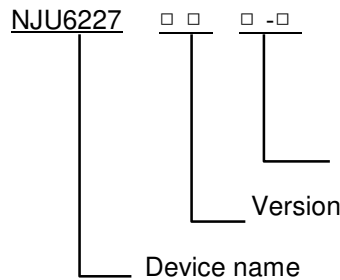

W-H: Wafer (200μm)
 W-B: Wafer (160μm)
 WS4-V: 1/4Wafer(130μm)
 C-V: Chip(130μm)

Starting Point: Die Center Unit[μm]
 Die Size: 0.73x0.63mm
 Die Thickness (C-V): 130±15μm
 Wafer Thickness(WS4-V): 130±15μm
 Wafer Thickness (W-B): 160±20μm
 Wafer Thickness (W-H): 200±20μm
 Pad size: 80x80μm
 Die Substrate: V_{SS} level

VERSION DISCRIMINATION INTERNAL COMPONENTS

PAD layout version of the NJU6227 series is determined by the mask pattern and Notch Number. Frequency version of the NJU6227 series is determined by the internal fuse trimming.

Type Number and PAD layout version are identified externally by the combination of the version name marking (1), the locations of trimmed fuses (3) and The Notch number (2). (Table 1 shows the chip version identification)

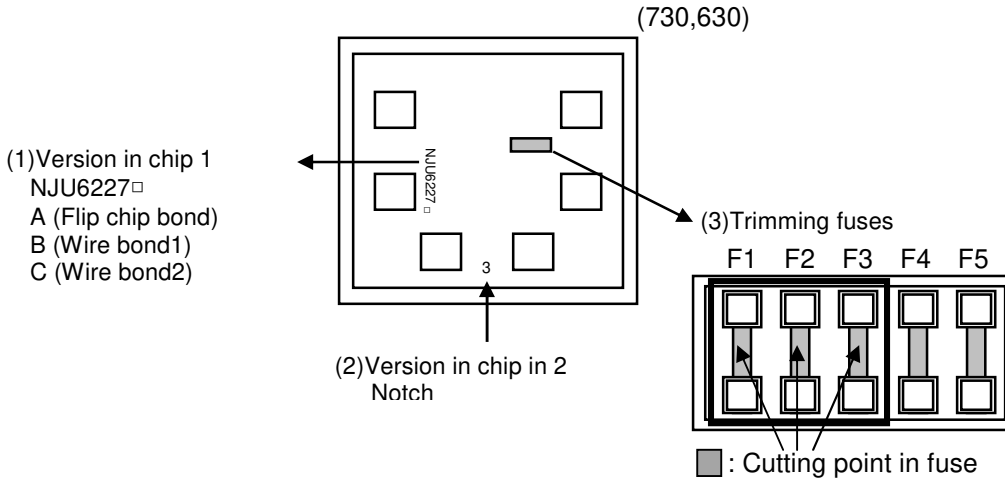

Table1: Frequency version and Cutting point in fuse.

Discrimination 1	Discrimination 2	Type No.	Version name	Mask / Version set by trimming fuses				
				Mask	Trimming fuses			
					Version	F1	F2	F3
NJU6227A	4	NJU6227A	NJU6227A1	A	*	-	-	Untrimmed
			NJU6227A2	A	*	-	*	
			NJU6227A3	A	-	-	-	
			NJU6227A4	A	-	-	*	
			NJU6227A5	A	-	*	-	
			NJU6227A6	A	-	*	*	
NJU6227C	4	NJU6227D	NJU6227D1	D	*	-	-	
			NJU6227D2	D	*	-	*	
			NJU6227D3	D	-	-	-	
			NJU6227D4	D	-	-	*	
			NJU6227D5	D	-	*	-	
			NJU6227D6	D	-	*	*	
NJU6227C	3	NJU6227C	NJU6227C1	C	*	-	-	
			NJU6227C2	C	*	-	*	
			NJU6227C3	C	-	-	-	
			NJU6227C4	C	-	-	*	
			NJU6227C5	C	-	*	-	
			NJU6227C6	C	-	*	*	

Note1) “- “: Uncut, “* “: Cutting

■ TERMINAL DESCRIPTION

SYMBOL	FUNCTION		
CONT	Oscillation and 3-state Output Buffer Control		
	<table border="1" style="width: 100%;"> <tr> <td style="width: 30%;">CONT</td> <td style="text-align: center;">F_{OUT}</td> </tr> </table>	CONT	F _{OUT}
	CONT	F _{OUT}	
	H or OPEN	Output frequency f ₀	
L	Oscillation Stop and High impedance Output		
XTI	Quartz Crystal Connecting Terminals		
XTO			
V _{SS}	GND Terminal (V _{SS} =0V)		
F _{OUT}	Frequency Output		
V _{DD}	V _{DD} =1.62 to 3.63V (x3, x4, x5, x6 2.25 to 3.63V)		

■ FUNCTIONAL DESCRIPTION

● Standby Function

When CONT Terminal goes “Low”, the F_{OUT} Terminal output becomes High impedance.

CONT	F _{OUT}	Oscillator
High(Open)	Frequency output	Normal operation
Low	High impedance	Stopped

● Variable Pull-up Resistance

The CONT Terminal pull-up resistance changes in response to the input level. When CONT is tied “LOW” level, the pull-up resistance is large, reducing the current consumed by the resistance. When CONT is left open circuit, the pull-up resistance is small, which increases the input susceptibility to external noise. However, the pull-up resistance ties the CONT Terminal “High” level to prevent external noise from unexpectedly stopping the output.

■ ABSOLUTE MAXIMUM RATINGS

(V_{SS}=0V, Ta=25°C)

PARAMETER	SYMBOL	RATING	UNIT
Supply Voltage	V _{DD}	-0.5 to +4.0	V
Input Voltage	V _{IN}	-0.5 to +4.0	V
Output Voltage	V _O	-0.5 to V _{DD} +0.5	V
Input Current	I _{IN}	±10	mA
Output Current	I _O	±25	mA
Operating Temperature Range	T _{opr}	-40 to +85	°C
Storage Temperature Range	T _{stg}	-55 to +125	°C

Note1) Input Voltage should be less than V_{DD} or 4.0V.

Note2) Decoupling capacitor should be connected between V_{DD} and V_{SS} due to the stabilized operation for the circuit.

■ ELECTRICAL CHARACTERISTICS

(Ta=+25°C)

PARAMETER	SYMBOL	CONDITIONS	MIN	TYP	MAX	UNIT
Operating Voltage	V _{DD}	x1,x2, version	1.62		3.63	V
Input Voltage	V _{IN}	CONT	0		3.63	V
Output Voltage	V _{OUT}	F _{OUT}	0		V _{DD}	V
Output Frequency Stability	df/f	V _{DD} ±10%		±1		ppm

(Ta=+25°C)

PARAMETER	SYMBOL	CONDITIONS	MIN	TYP	MAX	UNIT
Operating Voltage	V _{DD}	x3, x4, x5, x6 version	2.25		3.63	V
Input Voltage	V _{IN}	CONT	0		3.63	V
Output Voltage	V _{OUT}	F _{OUT}	0		V _{DD}	V
Output Frequency Stability	df/f	V _{DD} ±10%		±1		ppm

Note3) C0 minimum requirement

Version: x1, x2, x3, x4, x5 $1\text{pF} \leq C0 \leq 3\text{pF}$

Version: x6 $1.5\text{pF} \leq C0 \leq 3\text{pF}$

($V_{DD}=1.62$ to $3.63V$ (x3, x4, x5, x6 2.25 to $3.63V$), $V_{SS}=0V$, $T_a=+25^{\circ}C$)

PARAMETER	SYMBOL	CONDITIONS	MIN	TYP	MAX	UNIT	
Operating Current	I_{DD}	x1 version No load CONT=Open $f_{osc}=50MHz$	$V_{DD}=1.8V$	-	2.0	2.6	mA
			$V_{DD}=2.5V$	-	2.4	3.1	
			$V_{DD}=3.3V$	-	3.1	4.0	
		x2 version No load CONT=Open $f_{osc}=60MHz$	$V_{DD}=1.8V$	-	2.4	3.1	
			$V_{DD}=2.5V$	-	2.8	3.6	
			$V_{DD}=3.3V$	-	3.6	4.7	
		x3 version No load CONT=Open $f_{osc}=85MHz$	$V_{DD}=2.5V$	-	6.0	7.8	
			$V_{DD}=3.3V$	-	7.0	9.1	
		x4 version No load CONT=Open $f_{osc}=110MHz$	$V_{DD}=2.5V$	-	6.6	8.6	
			$V_{DD}=3.3V$	-	7.8	10.1	
		x5 version No load CONT=Open $f_{osc}=130MHz$	$V_{DD}=2.5V$	-	6.8	8.8	
			$V_{DD}=3.3V$	-	8.2	10.7	
		x6 version No load CONT=Open $f_{osc}=160MHz$	$V_{DD}=2.5V$	-	7.5	9.8	
			$V_{DD}=3.3V$	-	9.0	11.7	
Oscillation Stopping Current	I_{STB}	CONT= V_{SS} , No load	-	-	10	μA	
Output Voltage	V_{OH}	$I_{OH}=4mA$	$V_{DD}-0.4$	-	-	V	
	V_{OL}	$I_{OL}=4mA$	-	-	0.4	V	
Input Voltage	V_{IH}	CONT Input Tolerant Function	$0.7V_{DD}$	-	-	V	
	V_{IL}	CONT	-	-	$0.3V_{DD}$	V	
Input Current Note4)	I_{IN}	CONT= $3.63V$	-	-	1	μA	
		CONT= $0.8V_{DD}$	-	-	8		
		CONT= $0.2V_{DD}$	-	-	5		
3-state Off Leakage Current	I_{OZ}	CONT= V_{SS} , $F_{OUT}=V_{DD}$ or V_{SS}	-	-	± 0.1	μA	

Note4) Absolute value.

($V_{DD}=1.62$ to $3.63V$ (x3, x4, x5, x6 2.25 to $3.63V$), $V_{SS}=0V$, $T_a=+25^{\circ}C$)

PARAMETER	SYMBOL	CONDITIONS	MIN	TYP	MAX	UNIT	
Feedback Resistance	Rf	x1 version	-	12.5	-	kΩ	
		x2 version	-	6.8	-		
		x3 version	-	6.8	-		
		x4 version	-	12.3	-		
		x5 version	--	12.4	-		
		x6 version	-	12.5	-		
Internal Capacitor	Cg/Cd	x1 version	-	7.2/7.2	-	pF	
		x2 version	-	7.2/7.2	-		
		x3 version	-	7.2/7.2	-		
		x4 version	-	5.1/5.4	-		
		x5 version	-	4.2/4.1	-		
		x6 version	-	3.1/3.1	-		
Oscillation Frequency	fosc	Recommendation Note5)	40	-	50	MHz	
			50	-	60		
			60	-	85		
			85	-	110		
			110	-	130		
Output Signal Symmetry	SYM	$C_L=15pF$, @ $V_{DD}/2$	45	50	55	%	
Output Signal Rise Time	tr	NJU6227C $C_L=15pF$ $0.1V_{DD}$ to $0.9V_{DD}$	$V_{DD}=1.8V$	-	2.0	4.0	ns
			$V_{DD}=2.5V$	-	1.1	2.1	
			$V_{DD}=3.3V$	-	0.8	1.7	
		NJU6227A/D $C_L=15pF$ $0.1V_{DD}$ to $0.9V_{DD}$	$V_{DD}=1.8V$	-	2.75	5.5	
			$V_{DD}=2.5V$	-	1.4	2.8	
			$V_{DD}=3.3V$	-	1.1	2.2	
Output Signal Fall Time	tf	NJU6227C $C_L=15pF$ $0.9V_{DD}$ to $0.1V_{DD}$	$V_{DD}=1.8V$	-	1.7	3.4	
			$V_{DD}=2.5V$	-	1.0	1.9	
			$V_{DD}=3.3V$	-	0.8	1.5	
		NJU6227A/D $C_L=15pF$ $0.9V_{DD}$ to $0.1V_{DD}$	$V_{DD}=1.8V$	-	2.25	4.5	
			$V_{DD}=2.5V$	-	1.35	2.7	
			$V_{DD}=3.3V$	-	1.05	2.1	
Output Disable time	t_{POZ}	$C_L=15pF$, $R_L=1k\Omega$	-	-	100	ns	
Output Enable Time	t_{PZO}	$C_L=15pF$	-	-	1	ms	

Note5) The oscillation frequency range has used NJRC's standard crystal for measurement. However it is not guaranteed. (Refer to EXAMPLE OF CRYSTAL PARAMETERS FOR MEASUREMENT CIRCUITS)

■ EXAMPLE OF CRYSTAL PARAMETERS FOR MEASUREMENT CIRCUITS

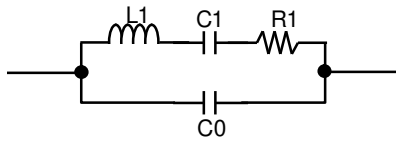

f[MHz]	R1[Ω]	L1[mH]	C1[fF]	C0[pF]
40	34.8	20.8	0.76	2.42
50	67.1	27.5	0.37	1.46
60	33.1	10.7	0.66	2.49
90	42.2	6.68	0.47	2.03
113	30.2	3.52	0.56	3.22
125	30.3	2.61	0.62	3.47
133	24.7	2.11	0.68	3.60
155	38.3	1.55	0.68	3.75

Note6) Please do use as small as possible parasitic capacitance of Crystal and V_{SS} , V_{DD} terminal.
When using for large size package, the parasitic capacitance upward tendency.

■ MEASUREMENT CIRCUITS

(1) Operating Current ($C_L=0pF$), Output Signal Symmetry ($C_L=15pF$), Output Signal Rise/Fall Time ($C_L=15pF$)

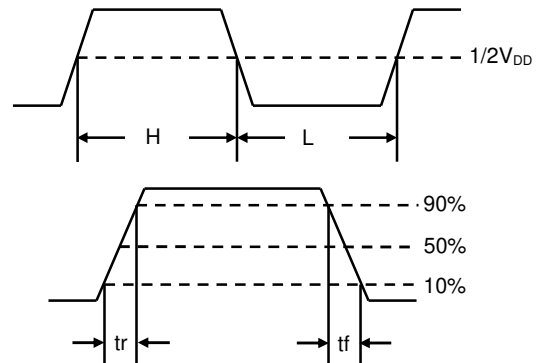
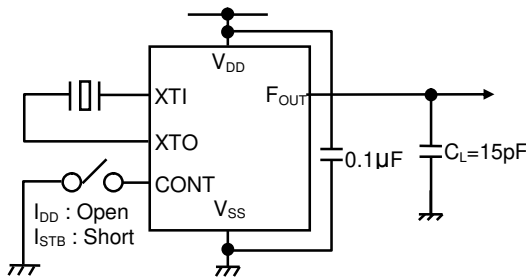

(2) Output Disable Time ($C_L=15pF, R_L=1k\Omega$)

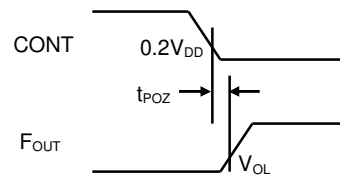
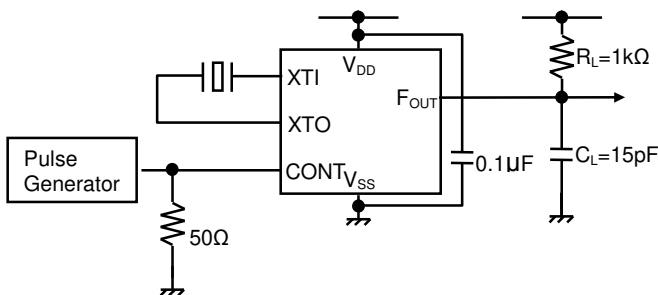

(3) Output Enable Time ($C_L=15pF$)

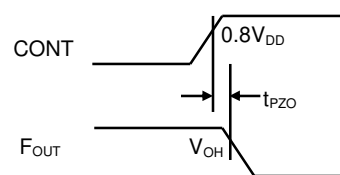
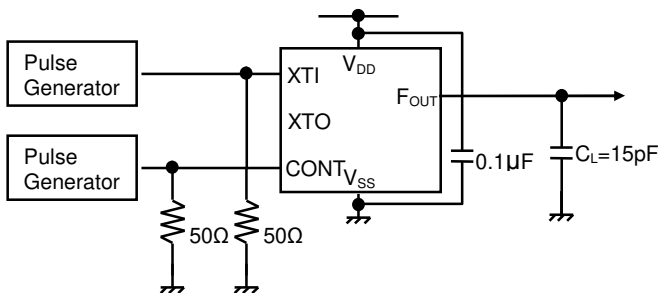

(4) Input Current ($C_L=15\text{pF}$)

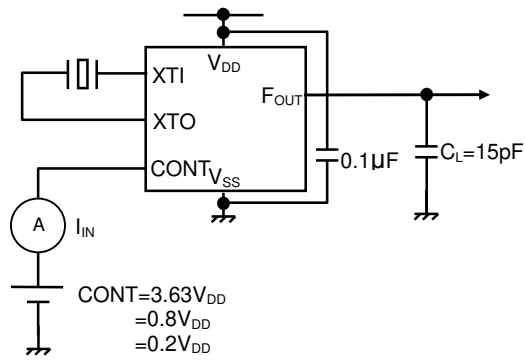

[CAUTION]
 The specifications on this data book are only given for information, without any guarantee as regards either mistakes or omissions. The application circuits in this data book are described only to show representative usages of the product and not intended for the guarantee or permission of any right including the industrial rights.