



Chipsmall Limited consists of a professional team with an average of over 10 year of expertise in the distribution of electronic components. Based in Hongkong, we have already established firm and mutual-benefit business relationships with customers from,Europe,America and south Asia,supplying obsolete and hard-to-find components to meet their specific needs.

With the principle of “Quality Parts,Customers Priority,Honest Operation,and Considerate Service”,our business mainly focus on the distribution of electronic components. Line cards we deal with include Microchip,ALPS,ROHM,Xilinx,Pulse,ON,Everlight and Freescale. Main products comprise IC,Modules,Potentiometer,IC Socket,Relay,Connector.Our parts cover such applications as commercial,industrial, and automotives areas.

We are looking forward to setting up business relationship with you and hope to provide you with the best service and solution. Let us make a better world for our industry!



## Contact us

Tel: +86-755-8981 8866 Fax: +86-755-8427 6832

Email & Skype: info@chipsmall.com Web: www.chipsmall.com

Address: A1208, Overseas Decoration Building, #122 Zhenhua RD., Futian, Shenzhen, China



## LOW INPUT OFFSET VOLTAGE C-MOS OPERATIONAL AMPLIFIER

### ■ GENERAL DESCRIPTION

The NJU7051/52 are single and dual C-MOS Operational Amplifiers operated on a single-power-supply, low voltage and low operating current.

The input offset voltage is lower than 2mV, and the input bias current is as low as less than 1pA, consequently the very small signal around the ground level can be amplified.

The minimum operating voltage is 1V and the output stage permits output signal to swing between both of the supply rails.

Furthermore, the operating current is also as low as 15μA (typ) per circuit, therefore it can be applied especially to battery operated items.

### ■ PACKAGE OUTLINE



NJU7051M  
NJU7052M



NJU7051V

### ■ FEATURES

- Single-Power-Supply
- Low Input Offset Voltage ( $V_{IO}=2\text{mV max}$ )
- Wide Operating Voltage ( $V_{DD}=1\sim 16\text{V}$ )
- Wide Output Swing Range ( $V_{OM}=2.94\text{V typ. @ } V_{DD}=3\text{V}$ )
- Low Operating Current ( $15\mu\text{A/circuit}$ )
- Low Bias Current ( $I_B=1\text{pA typ.}$ )
- Internal Compensation Capacitor
- External Offset Null Adjustment (Only NJU7051)
- Package Outline DMP/SSOP8 (NJU7051)  
DMP8 (NJU7052)
- C-MOS Technology

### ■ PIN CONFIGURATION

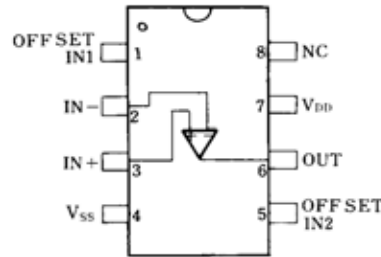

NJU7051M  
NJU7051V

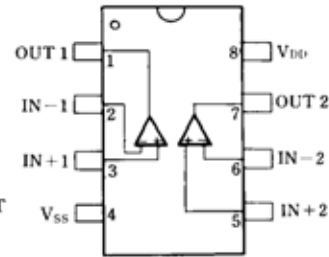

NJU7052M

### ■ EQUIVALENT CIRCUIT

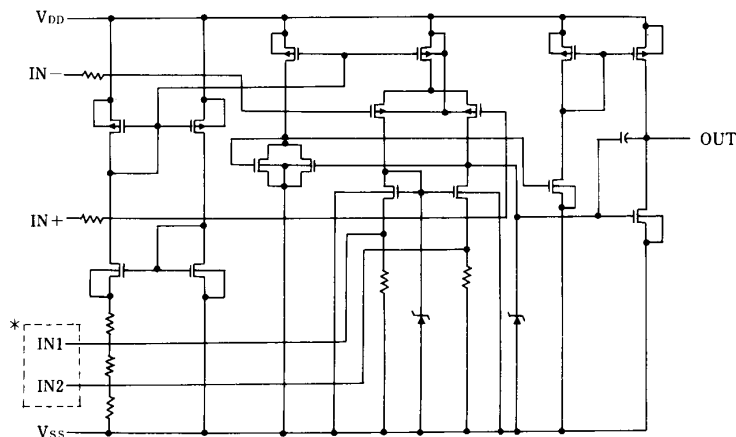

\* IN1, IN2 are only for NJU7051 (NJU7052 don't have these terminals).

# NJU7051/52

## ■ ABSOLUTE MAXIMUM RATINGS

(Ta=25°C)

PARAMETER	SYMBOL	RATINGS	UNIT
Supply Voltage	V <sub>DD</sub>	18	V
Differential Input Voltage	V <sub>ID</sub>	± 18 (note1)	V
Common Mode Input Voltage	V <sub>IC</sub>	-0.3~18	V
Power Dissipation	P <sub>D</sub>	(SSOP8) 250 (DMP8) 300	mW
Operating Temperature Range	T <sub>opr</sub>	-40~+85	°C
Storage Temperature Range	T <sub>stg</sub>	-40~+125	°C

(note1) If the supply voltage (V<sub>DD</sub>) is less than 18V, the input voltage must not over the V<sub>DD</sub> level though 18V is limit specified.

## ■ ELECTRICAL CHARACTERISTICS

(Ta=25°C, V<sub>DD</sub>=3V, R<sub>L</sub>=∞)

PARAMETER	SYMBOL	TEST CONDITION	MIN.	TYP.	MAX.	UNIT
Input Offset Voltage	V <sub>IO</sub>	R <sub>S</sub> =50Ω	-	-	2	mV
Input Offset Current	I <sub>IO</sub>		-	1	-	pA
Input Bias Current	I <sub>IB</sub>		-	1	-	pA
Input Impedance	R <sub>IN</sub>		-	1	-	TΩ
Large Signal Voltage Gain	A <sub>V</sub>		80	90	-	dB
Input Common Mode Voltage Range	V <sub>ICM</sub>		0~2	-	-	V
Maximum Output Swing Voltage	V <sub>OM</sub>	R <sub>L</sub> =1MΩ	2.90	2.94	-	V
Common Mode Rejection Ratio	CMR		60	70	-	dB
Supply Voltage Rejection Ratio	SVR		60	70	-	dB
Operating Current/Circuit	I <sub>DD</sub>		-	15	25	μA
Slew Rate	SR		-	0.05	-	V/μs
Unity Gain Bandwidth	F <sub>t</sub>	A <sub>V</sub> =40dB, C <sub>L</sub> =10pF	-	0.1	-	MHz

## ■ OFFSET ADJUSTMENT CIRCUIT (Only For NJU7051)

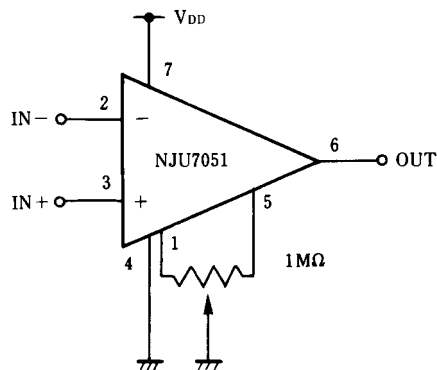

**[CAUTION]**

The specifications on this databook are only given for information, without any guarantee as regards either mistakes or omissions. The application circuits in this databook are described only to show representative usages of the product and not intended for the guarantee or permission of any right including the industrial rights.