



Chipsmall Limited consists of a professional team with an average of over 10 year of expertise in the distribution of electronic components. Based in Hongkong, we have already established firm and mutual-benefit business relationships with customers from,Europe,America and south Asia,supplying obsolete and hard-to-find components to meet their specific needs.

With the principle of “Quality Parts,Customers Priority,Honest Operation,and Considerate Service”,our business mainly focus on the distribution of electronic components. Line cards we deal with include Microchip,ALPS,ROHM,Xilinx,Pulse,ON,Everlight and Freescale. Main products comprise IC,Modules,Potentiometer,IC Socket,Relay,Connector.Our parts cover such applications as commercial,industrial, and automotives areas.

We are looking forward to setting up business relationship with you and hope to provide you with the best service and solution. Let us make a better world for our industry!



Contact us

Tel: +86-755-8981 8866 Fax: +86-755-8427 6832

Email & Skype: info@chipsmall.com Web: www.chipsmall.com

Address: A1208, Overseas Decoration Building, #122 Zhenhua RD., Futian, Shenzhen, China



High Precision C-MOS 3-Terminal Voltage Regulator

□ GENERAL DESCRIPTION

The NJU7231 is high precision output voltage 3-terminal positive voltage regulator.

The NJU7231 is suitable for battery operated items and battery back-up systems, because of low operating current and low dropout voltage.

□ PACKAGE OUTLINE



NJU7231U

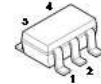

NJU7231F

□ FEATURES

- High Precision Output $V_o \pm 2\%$
- Low Operating Current 10 μ A typ.
- Low Dropout Voltage $\Delta V_{I-O} < 0.6V$ @ $I_o = 40mA$
- Wide Operating Voltage Range
- Package Outline SOT-89/SOT-23(MTP-5)
- Bipolar Technology

□ OUTPUT VOLTAGE RANK LIST

Output Voltage	SOT-89	SOT-23
+1.2V	NJU7231U12	NJU7231F12
+1.5V	NJU7231U15	NJU7231F15
+1.8V	NJU7231U18	NJU7231F18
+2.5V	NJU7231U25	NJU7231F25
+2.6V	NJU7231U26	NJU7231F26
+2.7V	NJU7231U27	NJU7231F27
+2.8V	NJU7231U28	NJU7231F28
+2.9V	NJU7231U29	NJU7231F29
+3.0V	NJU7231U30	NJU7231F30
+3.3V	NJU7231U33	NJU7231F33
+5.0V	NJU7231U50	NJU7231F50
+5.2V	NJU7231U52	NJU7231F52

□ TERMINAL DESCRIPTION

No.	Description	
	SOT-89	SOT-23
1	GND	GND
2	INPUT	INPUT
3	OUTPUT	OUTPUT
4	-	NC
5	-	NC

□ EQUIVALENT CIRCUIT

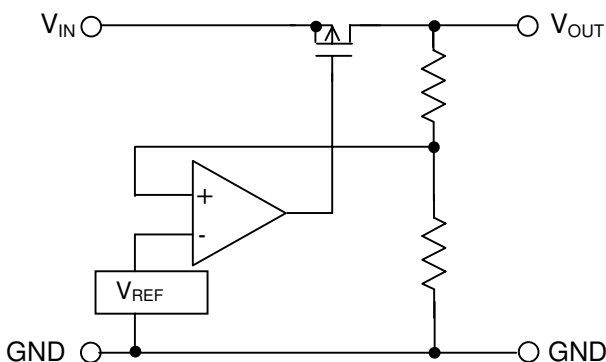

ABSOLUTE MAXIMUM RATING

(Ta=25°C)

PARAMETER	SYMBOL	RATINGS	UNIT
Input Voltage	V _{IN}	18	V
Output Voltage	V _{OUT}	GND-0.3 ~ V _{IN} +0.3	V
Output Current	I _{OUT}	100	mA
Power Dissipation	P _D	300 (SOT-89) 200 (MTP-5)	mW
Operating Temperature	Topr	- 40 ~ + 85	°C
Storage Temperature	Tstg	- 55 ~ +125	°C

ELECTRICAL CHARACTERISTICS

+1.2V Version

(C_{IN}=C_O=0.1uF, Ta=25°C)

PARAMETER	SYMBOL	CONDITION	MIN	TYP	MAX	UNIT	CIRCUIT
Output Voltage	V _{OUT}	V _{IN} =3.0V, I _{OUT} =5mA	1.176	1.200	1.224	V	1
Dropout Voltage	ΔV _{IO}	I _{OUT} =0.5mA	-	0.02	0.3	V	1
Input Voltage	V _{IN}		-	-	15	V	2
Operating Current	I _Q	V _{IN} =3.0V	-	10	20	uA	2
Load Regulation	ΔV _{OUT} /ΔI _{OUT}	V _{IN} =3.0V, I _{OUT} =1~15mA	-	10	180	mV	3
Line Regulation	ΔV _{OUT} /(ΔV _{IN} ·V _{OUT})	V _{IN} =1.5~12.0V	-	0.1	-	%/V	3

+1.5V Version

(C_{IN}=C_O=0.1uF, Ta=25°C)

PARAMETER	SYMBOL	CONDITION	MIN	TYP	MAX	UNIT	CIRCUIT
Output Voltage	V _{OUT}	V _{IN} =3.0V, I _{OUT} =5mA	1.470	1.500	1.530	V	1
Dropout Voltage	ΔV _{IO}	I _{OUT} =0.5mA	-	0.02	0.30	V	1
Input Voltage	V _{IN}		-	-	15	V	2
Operating Current	I _Q	V _{IN} =3.0V	-	10	20	uA	2
Load Regulation	ΔV _{OUT} /ΔI _{OUT}	V _{IN} =3.0V, I _{OUT} =1~15mA	-	10	180	mV	3
Line Regulation	ΔV _{OUT} /(ΔV _{IN} ·V _{OUT})	V _{IN} =1.5~12.0V	-	0.1	-	%/V	3

+1.8V Version

(C_{IN}=C_O=0.1uF, Ta=25°C)

PARAMETER	SYMBOL	CONDITION	MIN	TYP	MAX	UNIT	CIRCUIT
Output Voltage	V _{OUT}	V _{IN} =3.0V, I _{OUT} =5mA	1.764	1.800	1.836	V	1
Dropout Voltage	ΔV _{IO}	I _{OUT} =0.5mA	-	0.02	0.30	V	1
Input Voltage	V _{IN}		-	-	15	V	2
Operating Current	I _Q	V _{IN} =3.0V	-	10	20	uA	2
Load Regulation	ΔV _{OUT} /ΔI _{OUT}	V _{IN} =3.0V, I _{OUT} =1~15mA	-	10	180	mV	3
Line Regulation	ΔV _{OUT} /(ΔV _{IN} ·V _{OUT})	V _{IN} =2.1~12.0V	-	0.1	-	%/V	3

+2.5V Version

 (C_{IN}=C_O=0.1μF, Ta=25°C)

PARAMETER	SYMBOL	CONDITION	MIN	TYP	MAX	UNIT	CIRCUIT
Output Voltage	V _{OUT}	V _{IN} =4.5V, I _{OUT} =10mA	2.45	2.50	2.55	V	1
Dropout Voltage	ΔV _{IO}	I _{OUT} =20mA	-	0.2	0.6	V	1
Input Voltage	V _{IN}		-	-	15	V	2
Operating Current	I _Q	V _{IN} =4.5V	-	10	20	μA	2
Load Regulation	ΔV _{OUT} /ΔI _{OUT}	V _{IN} =4.5V, I _{OUT} =1~20mA	-	15	180	mV	3
Line Regulation	ΔV _{OUT} /(ΔV _{IN} ·V _{OUT})	V _{IN} =3.5~12.0V	-	0.1	-	%/V	3

+2.6V Version

 (C_{IN}=C_O=0.1μF, Ta=25°C)

PARAMETER	SYMBOL	CONDITION	MIN	TYP	MAX	UNIT	CIRCUIT
Output Voltage	V _{OUT}	V _{IN} =4.6V, I _{OUT} =10mA	2.548	2.600	2.652	V	1
Dropout Voltage	ΔV _{IO}	I _{OUT} =20mA	-	0.2	0.6	V	1
Input Voltage	V _{IN}		-	-	15	V	2
Operating Current	I _Q	V _{IN} =4.6V	-	10	20	μA	2
Load Regulation	ΔV _{OUT} /ΔI _{OUT}	V _{IN} =4.6V, I _{OUT} =1~20mA	-	15	180	mV	3
Line Regulation	ΔV _{OUT} /(ΔV _{IN} ·V _{OUT})	V _{IN} =3.6~12.0V	-	0.1	-	%/V	3

+2.7V Version

 (C_{IN}=C_O=0.1μF, Ta=25°C)

PARAMETER	SYMBOL	CONDITION	MIN	TYP	MAX	UNIT	CIRCUIT
Output Voltage	V _{OUT}	V _{IN} =4.7V, I _{OUT} =10mA	2.646	2.70	2.754	V	1
Dropout Voltage	ΔV _{IO}	I _{OUT} =20mA	-	0.2	0.6	V	1
Input Voltage	V _{IN}		-	-	15	V	2
Operating Current	I _Q	V _{IN} =4.7V	-	10	20	μA	2
Load Regulation	ΔV _{OUT} /ΔI _{OUT}	V _{IN} =4.7V, I _{OUT} =1~20mA	-	15	180	mV	3
Line Regulation	ΔV _{OUT} /(ΔV _{IN} ·V _{OUT})	V _{IN} =3.7~12.0V	-	0.1	-	%/V	3

+2.8V Version

 (C_{IN}=C_O=0.1μF, Ta=25°C)

PARAMETER	SYMBOL	CONDITION	MIN	TYP	MAX	UNIT	CIRCUIT
Output Voltage	V _{OUT}	V _{IN} =4.8V, I _{OUT} =10mA	2.744	2.800	2.856	V	1
Dropout Voltage	ΔV _{IO}	I _{OUT} =20mA	-	0.2	0.6	V	1
Input Voltage	V _{IN}		-	-	15	V	2
Operating Current	I _Q	V _{IN} =4.8V	-	10	20	μA	2
Load Regulation	ΔV _{OUT} /ΔI _{OUT}	V _{IN} =4.8V, I _{OUT} =1~20mA	-	15	180	mV	3
Line Regulation	ΔV _{OUT} /(ΔV _{IN} ·V _{OUT})	V _{IN} =3.8~12.0V	-	0.1	-	%/V	3

+2.9V Version

 (C_{IN}=C_O=0.1μF, Ta=25°C)

PARAMETER	SYMBOL	CONDITION	MIN	TYP	MAX	UNIT	CIRCUIT
Output Voltage	V _{OUT}	V _{IN} =4.9V, I _{OUT} =10mA	2.842	2.900	2.958	V	1
Dropout Voltage	ΔV _{IO}	I _{OUT} =20mA	-	0.2	0.6	V	1
Input Voltage	V _{IN}		-	-	15	V	2
Operating Current	I _Q	V _{IN} =4.9V	-	10	20	μA	2
Load Regulation	ΔV _{OUT} /ΔI _{OUT}	V _{IN} =4.9V, I _{OUT} =1~20mA	-	15	180	mV	3
Line Regulation	ΔV _{OUT} /(ΔV _{IN} ·V _{OUT})	V _{IN} =3.9~12.0V	-	0.1	-	%/V	3

+3.0V Version

($C_{IN}=C_O=0.1\mu F, T_a=25^\circ C$)

PARAMETER	SYMBOL	CONDITION	MIN	TYP	MAX	UNIT	CIRCUIT
Output Voltage	V_{OUT}	$V_{IN}=5.0V, I_{OUT}=10mA$	2.94	3.00	3.06	V	1
Dropout Voltage	ΔV_{IO}	$I_{OUT}=20mA$	-	0.2	0.6	V	1
Input Voltage	V_{IN}		-	-	15	V	2
Operating Current	I_Q	$V_{IN}=5.0V$	-	10	20	μA	2
Load Regulation	$\Delta V_{OUT}/\Delta I_{OUT}$	$V_{IN}=5.0V, I_{OUT}=1\sim 20mA$	-	15	180	mV	3
Line Regulation	$\Delta V_{OUT}/(\Delta V_{IN}\cdot V_{OUT})$	$V_{IN}=4.0\sim 12.0V$	-	0.1	-	%/V	3

+3.3V Version

($C_{IN}=C_O=0.1\mu F, T_a=25^\circ C$)

PARAMETER	SYMBOL	CONDITION	MIN	TYP	MAX	UNIT	CIRCUIT
Output Voltage	V_{OUT}	$V_{IN}=5.3V, I_{OUT}=10mA$	3.234	3.300	3.366	V	1
Dropout Voltage	ΔV_{IO}	$I_{OUT}=20mA$	-	0.2	0.6	V	1
Input Voltage	V_{IN}		-	-	15	V	2
Operating Current	I_Q	$V_{IN}=5.3V$	-	10	20	μA	2
Load Regulation	$\Delta V_{OUT}/\Delta I_{OUT}$	$V_{IN}=5.3V, I_{OUT}=1\sim 20mA$	-	15	180	mV	3
Line Regulation	$\Delta V_{OUT}/(\Delta V_{IN}\cdot V_{OUT})$	$V_{IN}=4.3\sim 12.0V$	-	0.1	-	%/V	3

+5.0V Version

($C_{IN}=C_O=0.1\mu F, T_a=25^\circ C$)

PARAMETER	SYMBOL	CONDITION	MIN	TYP	MAX	UNIT	CIRCUIT
Output Voltage	V_{OUT}	$V_{IN}=7.0V, I_{OUT}=30mA$	4.90	5.00	5.10	V	1
Dropout Voltage	ΔV_{IO}	$I_{OUT}=40mA$	-	0.3	0.6	V	1
Input Voltage	V_{IN}		-	-	15	V	2
Operating Current	I_Q	$V_{IN}=7.0V$	-	10	20	μA	2
Load Regulation	$\Delta V_{OUT}/\Delta I_{OUT}$	$V_{IN}=7.0V, I_{OUT}=1\sim 40mA$	-	35	120	mV	3
Line Regulation	$\Delta V_{OUT}/(\Delta V_{IN}\cdot V_{OUT})$	$V_{IN}=6.0\sim 12.0V$	-	0.1	-	%/V	3

+5.0V Version

($C_{IN}=C_O=0.1\mu F, T_a=25^\circ C$)

PARAMETER	SYMBOL	CONDITION	MIN	TYP	MAX	UNIT	CIRCUIT
Output Voltage	V_{OUT}	$V_{IN}=7.2V, I_{OUT}=30mA$	5.096	5.200	5.304	V	1
Dropout Voltage	ΔV_{IO}	$I_{OUT}=40mA$	-	0.3	0.6	V	1
Input Voltage	V_{IN}		-	-	15	V	2
Operating Current	I_Q	$V_{IN}=7.2V$	-	10	20	μA	2
Load Regulation	$\Delta V_{OUT}/\Delta I_{OUT}$	$V_{IN}=7.2V, I_{OUT}=1\sim 40mA$	-	35	120	mV	3
Line Regulation	$\Delta V_{OUT}/(\Delta V_{IN}\cdot V_{OUT})$	$V_{IN}=6.2\sim 12.0V$	-	0.1	-	%/V	3

□ MEASUREMENT CIRCUIT

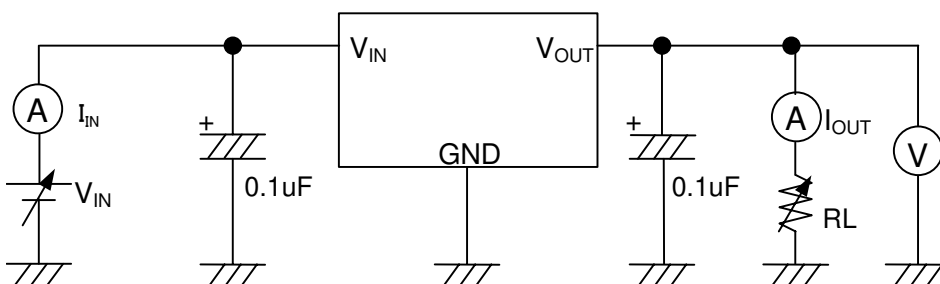

[CAUTION]

The specifications on this databook are only given for information, without any guarantee as regards either mistakes or omissions. The application circuits in this databook are described only to show representative usages of the product and not intended for the guarantee or permission of any right including the industrial rights.