



Chipsmall Limited consists of a professional team with an average of over 10 year of expertise in the distribution of electronic components. Based in Hongkong, we have already established firm and mutual-benefit business relationships with customers from,Europe,America and south Asia,supplying obsolete and hard-to-find components to meet their specific needs.

With the principle of “Quality Parts,Customers Priority,Honest Operation,and Considerate Service”,our business mainly focus on the distribution of electronic components. Line cards we deal with include Microchip,ALPS,ROHM,Xilinx,Pulse,ON,Everlight and Freescale. Main products comprise IC,Modules,Potentiometer,IC Socket,Relay,Connector.Our parts cover such applications as commercial,industrial, and automotives areas.

We are looking forward to setting up business relationship with you and hope to provide you with the best service and solution. Let us make a better world for our industry!



## Contact us

Tel: +86-755-8981 8866 Fax: +86-755-8427 6832

Email & Skype: info@chipsmall.com Web: www.chipsmall.com

Address: A1208, Overseas Decoration Building, #122 Zhenhua RD., Futian, Shenzhen, China



### Analog Signal Input Class D Amplifier for Piezo Speaker

#### ■ GENERAL DESCRIPTION

The **NJU8752/NJU8752B** is an analog signal input monaural class D amplifier for Piezo speaker. The **NJU8752/52B** includes Inversion operational amplifier input circuit, PWM modulator, an output-short protector and a low voltage detector. Input part operates on 3.3V(TYP) as power supply and Output part operates up to 16.0V(MAX). Therefore, it drives Piezo speaker with louder sound and High efficiency.

The **NJU8752/52B** incorporates BTL amplifier, which eliminate AC coupling capacitors, capable of driving Piezo speaker with simple external LC low-pass filters.

Class D operation achieves lower power operation for Piezo speaker, thus the **NJU8752/52B** is suited for battery powered applications.

#### ■ PACKAGE OUTLINE

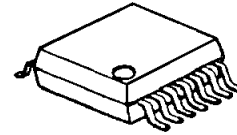

**NJU8752V / 52BV**

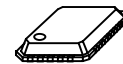

**NJU8752BKM1**

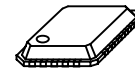

**NJU8752BKP4**

#### ■ FEATURES

- Piezo Speaker Driving
- 1-channel Analog Signal Input, 1-channel BTL Output
- Standby(Hi-Z), Mute Control
- Voltage Gain                   31dB(NJU8752)  
                                      20dB(NJU8752B)
- Built-in Low Voltage Detector
- Built-in Short Protector
- Operating Voltage   Input: 2.7 ~ 3.6V (NJU8752)  
                                      3.1 ~ 3.6V (NJU8752B)  
                                      Output: 6.0 ~ 16.0V
- C-MOS Technology
- Package Outline           SSOP14 (NJU8752 / 52B)  
                                      QFN20 / QFN28 (NJU8752B)

#### ■ PIN CONFIGURATION

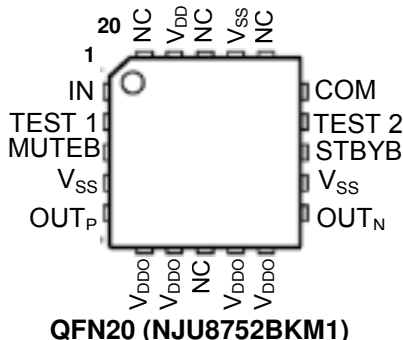
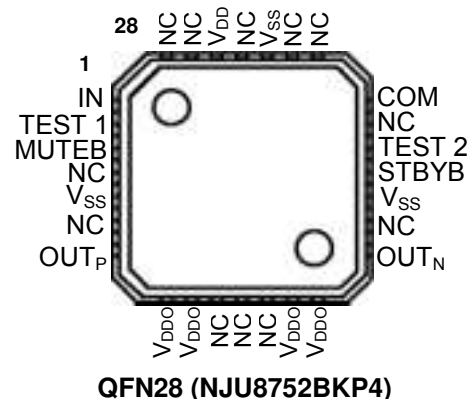
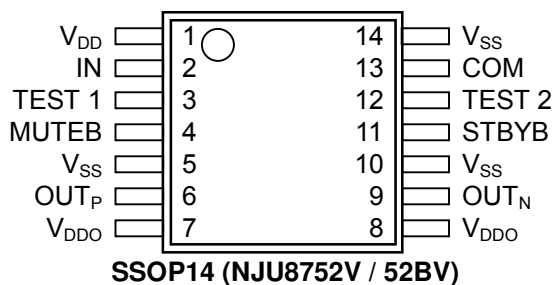

# NJU8752/52B

## ■ BLOCK DIAGRAM

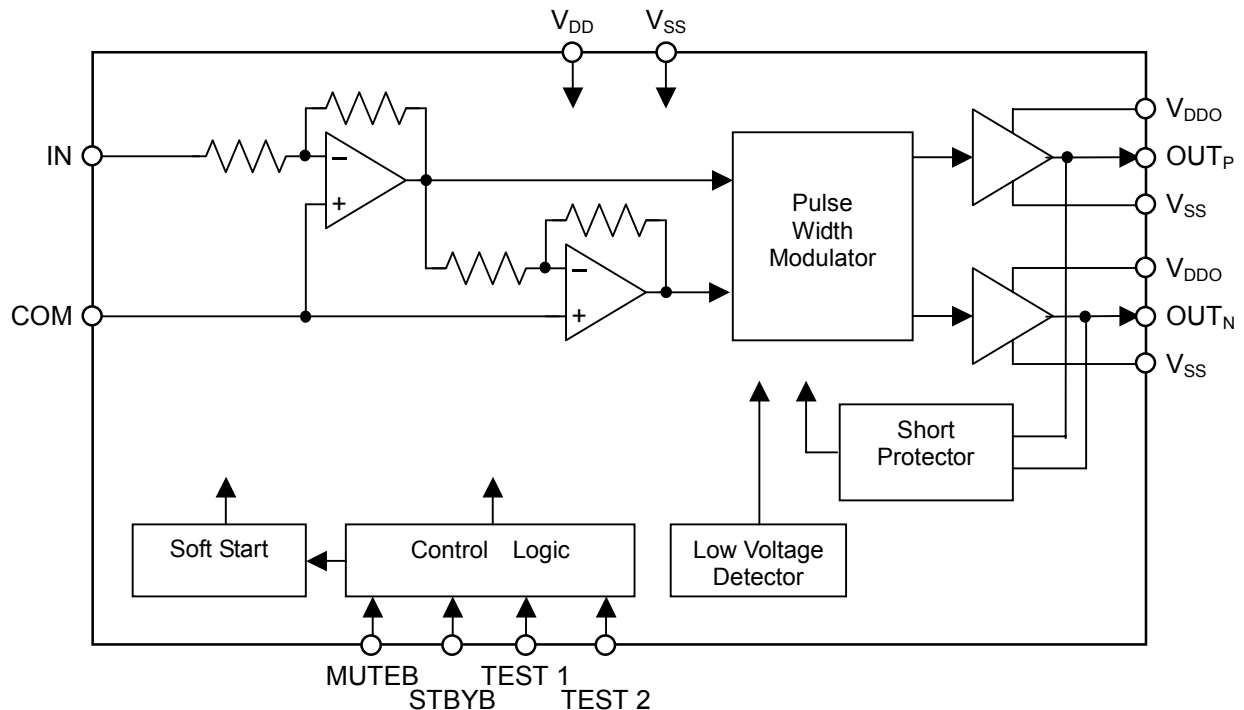

## ■ PIN DESCRIPTION

No.			SYMBOL	I/O	Function
SSOP14	QFN20	QFN28			
1	19	26	$V_{DD}$	–	Power Supply: $V_{DD}=3.3V$
2	1	1	IN	I	Signal Input
3	2	2	TEST 1	I	Maker test 1 This pin must be connected to GND.
4	3	3	MUTE B	I	Mute Control Low : Mute ON    High : Mute OFF
5,10,14	4,12,17	5,17,24	$V_{SS}$	–	Power GND: $V_{SS}=0V$
6	5	7	OUT <sub>P</sub>	O	Positive Output
7,8	6,7,9,10	8,9,13,14	$V_{DDO}$	–	Output Power Supply : $V_{DDO}=16.0V$ max.
9	11	15	OUT <sub>N</sub>	O	Negative Output
11	13	18	STBY B	I	Standby Control Low : Standby ON    High : Standby OFF
12	14	19	TEST 2	I	Maker test 2 This pin must be connected to GND.
13	15	21	COM	–	Analog common
–	8,16,18,20	4,6,10,11, 12,16,20,22, 23,25,27,28	NC	–	Non connection

\* $V_{SS}$ (SSOP14:Pin No.5,10,14, QFN20:Pin No.4,12,17, QFN28:Pin No.5,17,24) should be connected at a nearest point to the IC.

\* $V_{DDO}$ (SSOP14:Pin No.7,8, QFN20:Pin No.6,7,9,10, QFN28:Pin No.8,9,13,14) should be connected at a nearest point to the IC.

\*MUTE B(SSOP14: Pin No.4, QFN20, QFN28:Pin No.3) and STBY B(SSOP14:Pin No.11, QFN20:Pin No.13, QFN28:Pin No.18) must be connected to  $V_{DD}$ , when these pins are not used.

## ■ FUNCTIONAL DESCRIPTION

### (1) Signal Output

The  $OUT_P$  and  $OUT_N$  generate PWM output signals, which will be converted to analog signal via external 2nd-order or higher LC filter. A switching regulator with a high response against a voltage fluctuation is the best selection for the  $V_{DDO}$ , which are the power supply for output drivers. To obtain better THD performance, the stabilization of the power is required.

### (2) Standby

By setting the STBYB pin to "L", the standby mode is enabled. In the standby mode, the entire functions of the **NJU8752/52B** enter a low-power state, and the output pins ( $OUT_P$  and  $OUT_N$ ) are high impedance.

### (3) Mute

By setting the MUTEB pin to "L", the Mute function is enabled. In the Mute mode, the output pins ( $OUT_P$  and  $OUT_N$ ) output square wave (Duty: 50%).

### (4) Low Voltage Detector

When the power supply voltage drops down to below  $V_{DD}$  (MIN), the internal oscillation is halted for prevention to generate unwanted frequency, and the output pins ( $OUT_P$  and  $OUT_N$ ) become in high impedance.

### (5) Short Circuit Protection

The short protector, which protects the **NJU8752/52B** against high short-circuit current, turns off the output driver. After about 5 seconds from the protection, the **NJU8752/52B** returns to normal operation. The short protector functions at the following accidents.

- Short between  $OUT_P$  and  $OUT_N$
- Short between  $OUT_P$  and  $V_{SS}$
- Short between  $OUT_N$  and  $V_{SS}$

Note 1) The detectable current and the period for the protection depend on the power supply voltage and ambient temperature.

Note 2) The short protector is not effective for a long term short-circuit but for an instantaneous accident. Continuous high-current may cause permanent damage to the **NJU8752/52B**.

# NJU8752/52B

## ■ ABSOLUTE MAXIMUM RATINGS

(Ta=25°C)

PARAMETER	SYMBOL	RATING	UNIT
Supply Voltage	V <sub>DD</sub>	-0.3 ~ +4.0	V
	V <sub>DDO</sub>	-0.3 ~ +18.0	V
Input Voltage	V <sub>in</sub>	-0.3 ~ V <sub>DD</sub> +0.3	V
Operating Temperature	T <sub>opr</sub>	-40 ~ +85	°C
Storage Temperature	T <sub>stg</sub>	-40 ~ +125	°C
Power Dissipation	SSOP14	450	mW
	QFN20	620	
	QFN28	640	

\* : Mounted on two-layer board of based on the JEDEC.

Note 1) All voltage are relative to "V<sub>SS</sub>=0V" reference.

Note 2) The LSI must be used inside of the "Absolute maximum ratings". Otherwise, a stress may cause permanent damage to the LSI.

Note 3) De-coupling capacitors for V<sub>DD</sub>-V<sub>SS</sub> and V<sub>DDO</sub>-V<sub>SS</sub> should be connected for stable operation.

## ■ ELECTRICAL CHARACTERISTICS

### -NJU8752-

(Ta=25°C, V<sub>DD</sub>=3.3V, V<sub>DDO</sub>=12.0V, V<sub>SS</sub>=0V, Input Signal=1kHz, Input Signal Level=200mVrms, Frequency Band=20Hz~20kHz, Load Impedance=0.8μF, 2nd-order 34kHz LC Filter(Q=0.75))

PARAMETER	SYMBOL	CONDITIONS	MIN	TYP	MAX	UNIT	Note
V <sub>DD</sub> Supply Voltage	V <sub>DD</sub>		2.7	3.3	3.6	V	
V <sub>DDO</sub> Supply Voltage	V <sub>DDO</sub>		6.0	12.0	16.0	V	
Input Impedance	Z <sub>IN</sub>	IN pin	-	20	-	kΩ	
Voltage Gain	A <sub>V</sub>		-	31	-	dB	
Output THD	THD	Input Signal Level =200mVrms	-	0.05	0.08	%	4
Maximum Output	V <sub>o</sub>	Output THD=10%	7	10	-	Vrms	
S/N	SN	A weight	-	80	-	dB	4
Dynamic Range	Drange	A weight	-	83	-	dB	4
Maximum Mute Attenuation	MAT		90	-	-	dB	
Operating Current(Stanby)	I <sub>ST</sub>		-	-	1	μA	
Operating Current (No signal input)	I <sub>DD</sub>	No-load operating No Signal Input	-	3.5	10	mA	
Input Voltage	V <sub>IH</sub>	MUTE <sub>B</sub> , STBY <sub>B</sub> pins	0.7V <sub>DD</sub>	-	V <sub>DD</sub>	V	
	V <sub>IL</sub>	MUTE <sub>B</sub> , STBY <sub>B</sub> pins	0	-	0.3V <sub>DD</sub>	V	
Input Leakage Current	I <sub>LK</sub>	MUTE <sub>B</sub> , STBY <sub>B</sub> pins	-	-	±1.0	μA	

**-NJU8752B-**

(Ta=25°C, V<sub>DD</sub>=3.3V, V<sub>DDO</sub>=12.0V, V<sub>SS</sub>=0V, Input Signal=1kHz, Input Signal Level=700mVrms, Frequency Band=20Hz~20kHz, Load Impedance=0.8μF, 2nd-order 34kHz LC Filter(Q=0.75))

PARAMETER	SYMBOL	CONDITIONS	MIN	TYP	MAX	UNIT	Note
V <sub>DD</sub> Supply Voltage	V <sub>DD</sub>		3.1	3.3	3.6	V	
V <sub>DDO</sub> Supply Voltage	V <sub>DDO</sub>		6.0	12.0	16.0	V	
Input Impedance	Z <sub>IN</sub>	IN pin	-	20	-	kΩ	
Voltage Gain	A <sub>V</sub>		-	20	-	dB	
Output THD	THD	Input Signal Level =700mVrms	-	0.05	0.08	%	4
Maximum Output	V <sub>o</sub>	Output THD=10%	7	10	-	Vrms	
S/N	SN	A weight	-	80	-	dB	4
Dynamic Range	Drange	A weight	-	83	-	dB	4
Maximum Mute Attenuation	MAT		-	90	-	dB	
Operating Current(Stanby)	I <sub>ST</sub>		-	-	1	μA	
Operating Current (No signal input)	I <sub>DD</sub>	No-load operating No Signal Input	-	3.5	10	mA	
Input Voltage	V <sub>IH</sub>	MUTE <sub>B</sub> , STBY <sub>B</sub> pins	0.7V <sub>DD</sub>	-	V <sub>DD</sub>	V	
	V <sub>IL</sub>	MUTE <sub>B</sub> , STBY <sub>B</sub> pins	0	-	0.3V <sub>DD</sub>	V	
Input Leakage Current	I <sub>LK</sub>	MUTE <sub>B</sub> , STBY <sub>B</sub> pins	-	-	±1.0	μA	

Note 4) Test system of the output THD, S/N and Dynamic Range

The output THD, S/N and dynamic range are tested in the system shown in Figure 1, where a 2nd-order LC LPF and another filter incorporated in an audio analyzer are used.

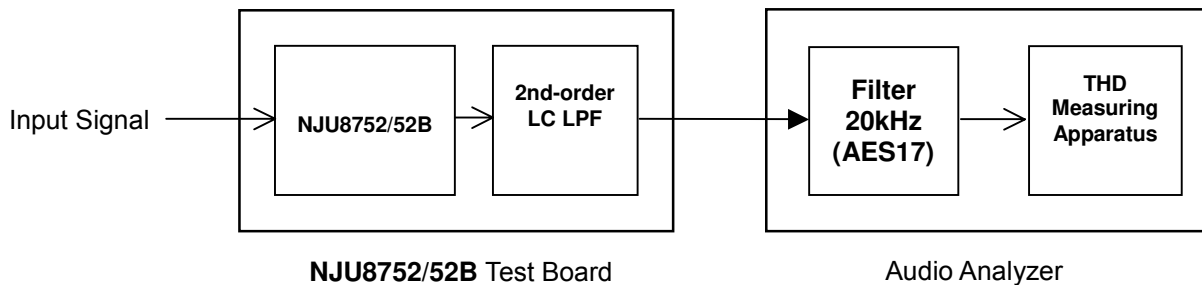

Figure 1. Output THD, S/N and Dynamic Range Test System

2nd-order LPF : Refer to "Typical Application Circuit".  
 Filters : 22Hz HPF + 20kHz LPF(AES17)  
 (with the A-Weight filter for S/N and Dynamic-range tests)

# NJU8752/52B

## ■ TYPICAL APPLICATION CIRCUIT

•LLB2520 is manufactured by TOKO, INC.  
For detail information, please refer its technical papers.

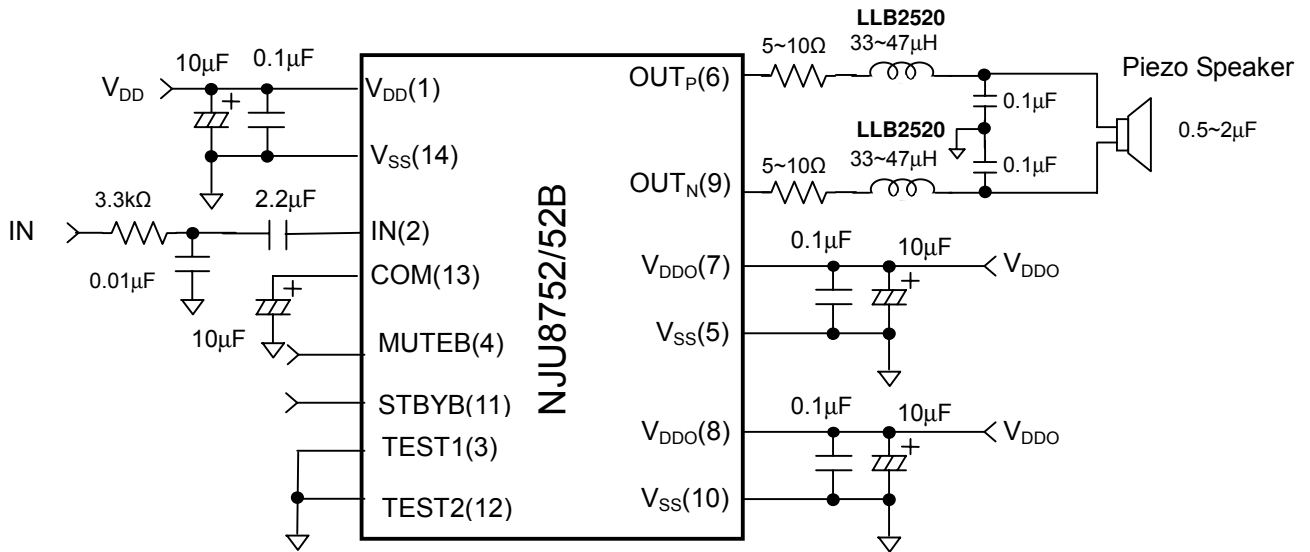

Figure 2.1 Application Circuit example (SSOP14)

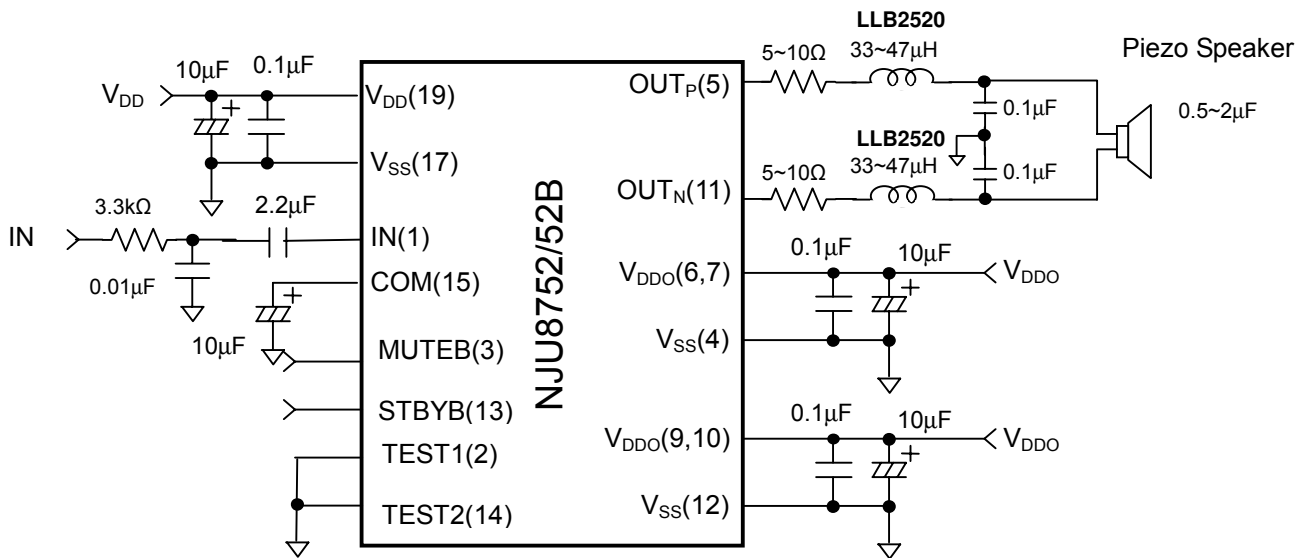

Figure 2.2 Application Circuit example (QFN20)

•LLB2520 is manufactured by TOKO, INC.  
For detail information, please refer its technical papers.

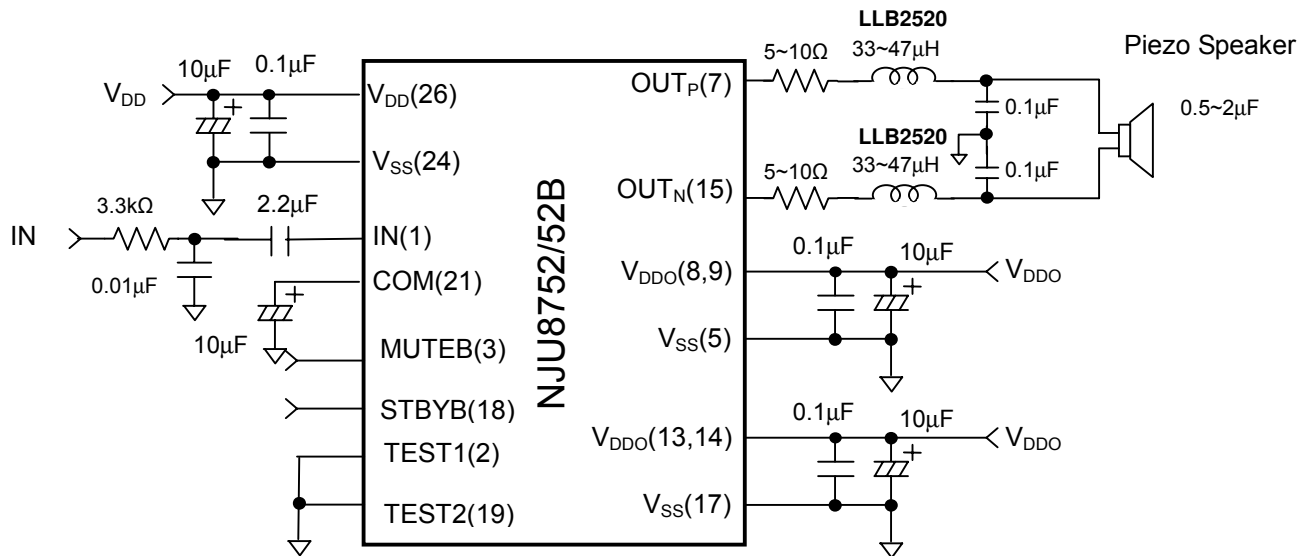

Figure 2.3 Application Circuit example (QFN28)

- Note 5) De-coupling capacitors must be connected between each power supply pin and GND.  
The capacity value should be adjusted on the application circuit and the operation temperature. It may malfunction if capacity value is small.
- Note 6) The power supply for  $V_{DDO}$  require fast driving response performance such as a switching regulator for better THD.  
THD performance becomes worse by ripple if the capacity of De-coupling capacitors is small.
- Note 7) The above circuit shows only application example and does not guarantee the any electrical characteristics. Therefore, please test the circuit carefully to fit your application.  
The cutoff frequency of the LC filter influences the quality of sound.  
The Q factor of the LC filter must be less than "1". Otherwise, the operating current increase when the frequency of input signal is closed to the cutoff frequency.
- Note 8) The transition time for MUTE B and STBY B signals must be less than 100μs. Otherwise, a malfunction may be occurred.
- Note 9) (1)-(26) indicates pin number.

[CAUTION]  
The specifications on this databook are only given for information, without any guarantee as regards either mistakes or omissions. The application circuits in this databook are described only to show representative usages of the product and not intended for the guarantee or permission of any right including the industrial rights.