



Chipsmall Limited consists of a professional team with an average of over 10 year of expertise in the distribution of electronic components. Based in Hongkong, we have already established firm and mutual-benefit business relationships with customers from,Europe,America and south Asia,supplying obsolete and hard-to-find components to meet their specific needs.

With the principle of “Quality Parts,Customers Priority,Honest Operation,and Considerate Service”,our business mainly focus on the distribution of electronic components. Line cards we deal with include Microchip,ALPS,ROHM,Xilinx,Pulse,ON,Everlight and Freescale. Main products comprise IC,Modules,Potentiometer,IC Socket,Relay,Connector.Our parts cover such applications as commercial,industrial, and automotives areas.

We are looking forward to setting up business relationship with you and hope to provide you with the best service and solution. Let us make a better world for our industry!



## Contact us

Tel: +86-755-8981 8866 Fax: +86-755-8427 6832

Email & Skype: info@chipsmall.com Web: www.chipsmall.com

Address: A1208, Overseas Decoration Building, #122 Zhenhua RD., Futian, Shenzhen, China



# NLAS3158

## Low Voltage Dual SPDT Analog Switch Dual 2:1 Multiplexer

The NLAS3158 is an advanced CMOS analog switch fabricated with silicon gate CMOS technology. It achieves very low propagation delay and  $R_{DS(ON)}$  resistances while maintaining CMOS low power dissipation. Analog and digital voltages that may vary across the full power-supply range (from  $V_{CC}$  to GND). This device is a drop in replacement for the PI5A3158.

The select pin has overvoltage protection that allows voltages above  $V_{CC}$ , up to 7.0 V to be present on the pin without damage or disruption of operation of the part, regardless of the operating voltage.

### Features

- High Speed:  $t_{PD} = 1.0$  ns (Typ) at  $V_{CC} = 5.0$  V
- Low Power Dissipation:  $I_{CC} = 1.0$   $\mu$ A (Max) at  $T_A = 25^\circ$ C
- Standard CMOS Logic Levels
- High Bandwidth, Improved Linearity
- Low  $R_{DS(ON)}$ : 8  $\Omega$  Max at 3 V
- Break Before Make Circuitry, Prevents Inadvertent Shorts
- This is a Pb-Free Device

### Typical Applications

- Switches Standard NTSC/PAL Video, Audio, SPDIF and HDTV
- May be used for Clock Switching, Data MUX'ing, etc.
- Can Switch Balanced Signal Pairs, e.g. LVDS > 200 Mb/s

### Important Information

- Latchup Performance Exceeds 300 mA
- Pin for Pin Drop in for PI5A3158
- WDFN Package, 3x1 mm
- ESD Performance: Human Body Model; > 2000 V;  
Machine Model; > 200 V
- Extended Automotive Temperature Range  $-55^\circ$ C to  $+125^\circ$ C (See Appendix A)



ON Semiconductor®

[www.onsemi.com](http://www.onsemi.com)

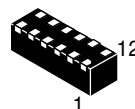

WDFN12  
MN SUFFIX  
CASE 485AG

### MARKING DIAGRAM



1

AS = Specific Device Code  
 $\bar{M}$  = Date Code  
 ■ = Pb-Free Package  
 (Note: Microdot may be in either location)

### FUNCTION TABLE

Select Input	Function
L	B0 Connected to A
H	B1 Connected to A

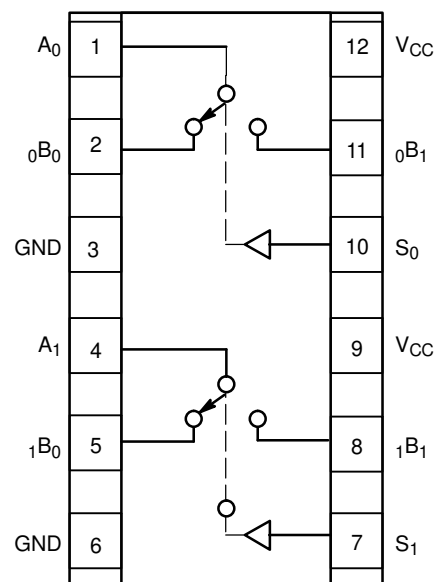

Figure 1. Pinout (Top View)

### ORDERING INFORMATION

See detailed ordering and shipping information in the package dimensions section on page 11 of this data sheet.

# NLAS3158

## MAXIMUM RATINGS

Rating	Symbol	Value	Unit
Supply Voltage	$V_{CC}$	-0.5 to +7.0	V
DC Switch Input Voltage (Note 1)	$V_{IS}$	-0.5 to $V_{CC} + 0.5$	V
DC Input Voltage (Note 1)	$V_{IN}$	-0.5 to +7.0	V
DC Input Diode Current @ $V_{IN} < 0$ V	$I_{IK}$	-50	mA
DC Output Current	$I_{OUT}$	128	mA
DC $V_{CC}$ or Ground Current	$I_{CC}/I_{GND}$	+100	mA
Storage Temperature Range	$T_{stg}$	-65 to +150	°C
Junction Temperature Under Bias	$T_J$	150	°C
Junction Lead Temperature (Soldering, 10 Seconds)	$T_L$	260	°C
Power Dissipation @ +85°C	$P_D$	180	mW

Stresses exceeding those listed in the Maximum Ratings table may damage the device. If any of these limits are exceeded, device functionality should not be assumed, damage may occur and reliability may be affected.

1. The input and output negative voltage ratings may be exceeded if the input and output diode current ratings are observed.

## RECOMMENDED OPERATING CONDITIONS (Note 2)

Characteristic	Symbol	Min	Max	Unit
Supply Voltage Operating	$V_{CC}$	1.65	5.5	V
Select Input Voltage	$V_{IN}$	0	$V_{CC}$	V
Switch Input Voltage	$V_{IS}$	0	$V_{CC}$	V
Output Voltage	$V_{OUT}$	0	$V_{CC}$	V
Operating Temperature	$T_A$	-55	+125	°C
Input Rise and Fall Time Control Input $V_{CC} = 2.3$ V–3.6 V Control Input $V_{CC} = 4.5$ V–5.5 V	$t_r, t_f$	0 0	10 5.0	ns/V
Thermal Resistance	$\theta_{JA}$	–	350	°C/W

Functional operation above the stresses listed in the Recommended Operating Ranges is not implied. Extended exposure to stresses beyond the Recommended Operating Ranges limits may affect device reliability.

2. Select input must be held HIGH or LOW, it must not float.

# NLAS3158

## DC ELECTRICAL CHARACTERISTICS ( $T_A = -40^{\circ}\text{C}$ to $+85^{\circ}\text{C}$ )

Symbol	Parameter	Test Conditions	$V_{CC}$ (V)	$T_A = +25^{\circ}\text{C}$			$T_A = -40^{\circ}\text{C}$ to $+85^{\circ}\text{C}$		Unit
				Min	Typ	Max	Min	Max	
$V_{IH}$	HIGH Level Input Voltage		1.65–1.95 2.3–5.5				$0.75 V_{CC}$ $0.7 V_{CC}$		V
$V_{IL}$	LOW Level Input Voltage		1.65–1.95 2.3–5.5					$0.25 V_{CC}$ $0.3 V_{CC}$	V
$I_{IN}$	Input Leakage Current	$0 \leq V_{IN} \leq 5.5 \text{ V}$	0–5.5		$\pm 0.0$ 5	$\pm 0.1$		$\pm 1$	$\mu\text{A}$
$I_{OFF}$	OFF State Leakage Current	$0 \leq A, B \leq V_{CC}$	1.65–5.5		$\pm 0.0$ 5	$\pm 0.1$		$\pm 1$	$\mu\text{A}$
$R_{ON}$	Switch On Resistance (Note 3)	$V_{IN} = 0 \text{ V}, I_O = 30 \text{ mA}$	4.5		3.0	6.0		6.0	$\Omega$
		$V_{IN} = 2.4 \text{ V}, I_O = -30 \text{ mA}$			5.0	8.0		8.0	
		$V_{IN} = 4.5 \text{ V}, I_O = -30 \text{ mA}$			7.0	13		13	
		$V_{IN} = 0 \text{ V}, I_O = 24 \text{ mA}$	3.0		4.0	8.0		8.0	$\Omega$
		$V_{IN} = 3 \text{ V}, I_O = -24 \text{ mA}$			10	19		19	$\Omega$
		$V_{IN} = 0 \text{ V}, I_O = 8 \text{ mA}$	2.3		5.0	9.0		9.0	$\Omega$
		$V_{IN} = 2.3 \text{ V}, I_O = -8 \text{ mA}$			13	24		24	$\Omega$
		$V_{IN} = 0 \text{ V}, I_O = 4 \text{ mA}$	1.65		6.5	12		12	$\Omega$
		$V_{IN} = 1.65 \text{ V}, I_O = -4 \text{ mA}$			17	39		39	$\Omega$
$I_{CC}$	Quiescent Supply Current All Channels ON or OFF	$V_{IN} = V_{CC}$ or GND  $I_{OUT} = 0$	5.5			1.0		10	$\mu\text{A}$
	Analog Signal Range		$V_{CC}$	0		$V_{CC}$	0	$V_{CC}$	V
$R_{RANGE}$	On Resistance Over Signal Range (Note 3) (Note 7)	$I_A = -30 \text{ mA}, 0 \leq V_{Bn} \leq V_{CC}$	4.5					25	$\Omega$
		$I_A = -24 \text{ mA}, 0 \leq V_{Bn} \leq V_{CC}$	3.0					50	
		$I_A = -8 \text{ mA}, 0 \leq V_{Bn} \leq V_{CC}$	2.3					100	
		$I_A = -4 \text{ mA}, 0 \leq V_{Bn} \leq V_{CC}$	1.65					300	
$\Delta R_{ON}$	On Resistance Match Between Channels (Note 3) (Note 4) (Note 5)	$I_A = -30 \text{ mA}, V_{Bn} = 3.15$	4.5		0.15				$\Omega$
		$I_A = -24 \text{ mA}, V_{Bn} = 2.1$	3.0		0.2				
		$I_A = -8 \text{ mA}, V_{Bn} = 1.6$	2.3		0.5				
		$I_A = -4 \text{ mA}, V_{Bn} = 1.15$	1.65		0.5				
$R_{flat}$	On Resistance Flatness (Note 3) (Note 4) (Note 6)	$I_A = -30 \text{ mA}, 0 \leq V_{Bn} \leq V_{CC}$	5.0		5.0				$\Omega$
		$I_A = -24 \text{ mA}, 0 \leq V_{Bn} \leq V_{CC}$	3.3		10				
		$I_A = -8 \text{ mA}, 0 \leq V_{Bn} \leq V_{CC}$	2.5		24				
		$I_A = -4 \text{ mA}, 0 \leq V_{Bn} \leq V_{CC}$	1.8		110				

Product parametric performance is indicated in the Electrical Characteristics for the listed test conditions, unless otherwise noted. Product performance may not be indicated by the Electrical Characteristics if operated under different conditions.

- Measured by the voltage drop between A and B pins at the indicated current through the switch. On Resistance is determined by the lower of the voltages on the two (A or B Ports).
- Parameter is characterized but not tested in production.
- $\Delta R_{ON} = R_{ON} \text{ max} - R_{ON} \text{ min}$  measured at identical  $V_{CC}$ , temperature and voltage levels.
- Flatness is defined as the difference between the maximum and minimum value of On Resistance over the specified range of conditions.
- Guaranteed by Design.

# NLAS3158

## AC ELECTRICAL CHARACTERISTICS ( $T_A = -40^{\circ}\text{C}$ to $+85^{\circ}\text{C}$ )

Symbol	Parameter	Test Conditions	$V_{CC}$ (V)	$T_A = +25^{\circ}\text{C}$			$T_A = -40^{\circ}\text{C}$ to $+85^{\circ}\text{C}$		Unit	Figure Number
				Min	Typ	Max	Min	Max		
$t_{PHL}$ $t_{PLH}$	Propagation Delay Bus to Bus (Note 9)	$V_I = \text{OPEN}$	1.65–1.95 2.3–2.7 3.0–3.6 4.5–5.5			1.2 0.8 0.3			ns	Figures 2, 3
$t_{PZL}$ $t_{PZH}$	Output Enable Time Turn On Time (A to $B_n$ )	$V_I = 2 \times V_{CC}$ for $t_{PZL}$ $V_I = 0\text{ V}$ for $t_{PZH}$	1.65–1.95 2.3–2.7 3.0–3.6 4.5–5.5			23 13 6.9 5.2	7.0 3.5 2.5 1.7	24 14 7.6 5.7	ns	Figures 2, 3
$t_{PLZ}$ $t_{PHZ}$	Output Disable Time Turn Off Time (A Port to B Port)	$V_I = 2 \times V_{CC}$ for $t_{PLZ}$ $V_I = 0\text{ V}$ for $t_{PHZ}$	1.65–1.95 2.3–2.7 3.0–3.6 4.5–5.5			12.5 7.0 5.0 3.5	3.0 2.0 1.5 0.8	13 7.5 5.3 3.8	ns	Figures 2, 3
$t_{BBM}$	Break Before Make Time (Note 8)	$R_L = 50\ \Omega$ $C_L = 35\ \text{pF}$	1.65–1.95 2.3–2.7 3.0–3.6 4.5–5.5	0.5 0.5 0.5 0.5			0.5 0.5 0.5 0.5		ns	Figure 4
Q	Charge Injection (Note 8)	$C_L = 0.1\ \text{nF}$ , $V_{GEN} = 0\text{ V}$ $R_{GEN} = 0\ \Omega$	5.0 3.3		7.0 3.0				pC	Figure 5
OIRR	Off Isolation (Note 10) NO	$R_L = 50\ \Omega$ $f = 10\ \text{MHz}$	1.65–5.5		-55				dB	Figures 6, 16
OIRR	Off Isolation (Note 10) NC	$R_L = 50\ \Omega$ $f = 10\ \text{MHz}$	1.65–5.5		-48				dB	Figures 6, 16
Xtalk	Crosstalk	$R_L = 50\ \Omega$ $f = 10\ \text{MHz}$	1.65–5.5		-54				dB	Figure 7
BW	-3 dB Bandwidth	$R_L = 50\ \Omega$	2.5–5.5		250				MHz	Figures 10, 15
THD	Total Harmonic Distortion (Note 8)	$R_L = 600\ \Omega$ $0.5\ V_{P-P}$ $f = 600\ \text{Hz}$ to $20\ \text{kHz}$	2.5 5.0		0.014 0.004				%	Figure 11

## CAPACITANCE (Note 11)

Symbol	Parameter	Test Conditions	Typ	Max	Unit	Figure Number
$C_{IN}$	Select Pin Input Capacitance	$V_{CC} = 0\text{ V}$	2.3		pF	
$C_{IO-B}$	B Port Off Capacitance	$V_{CC} = 5.0\text{ V}$	6.5		pF	Figure 8
$C_{IOA-ON}$	A Port Capacitance when Switch is Enabled	$V_{CC} = 5.0\text{ V}$	18.5		pF	Figure 9

8. Guaranteed by Design.

9. This parameter is guaranteed by design but not tested. The bus switch contributes no propagation delay other than the RC delay of the On Resistance of the switch and the 35 pF load capacitance, when driven by an ideal voltage source (zero output impedance).

10. Off Isolation =  $20 \log_{10} [V_A/V_{Bn}]$ .

11.  $T_A = +25^{\circ}\text{C}$ ,  $f = 1\ \text{MHz}$ , Capacitance is characterized but not tested in production.

APPENDIX A

DC ELECTRICAL EXTENDED AUTOMOTIVE TEMPERATURE RANGE CHARACTERISTICS (Note 14)

Symbol	Parameter	Test Conditions	V <sub>CC</sub> (V)	T <sub>A</sub> = +25°C			T <sub>A</sub> = -55°C to +125°C		Unit
				Min	Typ	Max	Min	Max	
V <sub>IH</sub>	HIGH Level Input Voltage		1.65–1.95 2.3–5.5				0.75 V <sub>CC</sub> 0.7 V <sub>CC</sub>		V
V <sub>IL</sub>	LOW Level Input Voltage		1.65–1.95 2.3–5.5					0.25 V <sub>CC</sub> 0.3 V <sub>CC</sub>	V
I <sub>IN</sub>	Input Leakage Current	0 ≤ V <sub>IN</sub> ≤ 5.5 V	0–5.5		±0.05	±0.1		±1	μA
I <sub>OFF</sub>	OFF State Leakage Current	0 ≤ A, B ≤ V <sub>CC</sub>	1.65–5.5		±0.05	±0.1		±1	μA
R <sub>ON</sub>	Switch On Resistance (Note 12)	V <sub>IN</sub> = 0 V, I <sub>O</sub> = 30 mA	4.5		3.0			8.5	Ω
		V <sub>IN</sub> = 2.4 V, I <sub>O</sub> = -30 mA			5.0			13.0	
		V <sub>IN</sub> = 4.5 V, I <sub>O</sub> = -30 mA			7.0			15.0	
		V <sub>IN</sub> = 0 V, I <sub>O</sub> = 24 mA	3.0		4.0			11	
		V <sub>IN</sub> = 3 V, I <sub>O</sub> = -24 mA			10			20	
		V <sub>IN</sub> = 0 V, I <sub>O</sub> = 8 mA	2.3		5.0			12	
		V <sub>IN</sub> = 2.3 V, I <sub>O</sub> = -8 mA			13			30	
		V <sub>IN</sub> = 0 V, I <sub>O</sub> = 4 mA	1.65		6.5			20	
		V <sub>IN</sub> = 1.65 V, I <sub>O</sub> = -4 mA			17			50	
I <sub>CC</sub>	Quiescent Supply Current All Channels ON or OFF	V <sub>IN</sub> = V <sub>CC</sub> or GND I <sub>OUT</sub> = 0	5.5			1.0		10	μA
	Analog Signal Range		V <sub>CC</sub>	0		V <sub>CC</sub>	0	V <sub>CC</sub>	V
R <sub>RANGE</sub>	On Resistance Over Signal Range (Note 12) (Note 13)	I <sub>A</sub> = -30 mA, 0 ≤ V <sub>Bn</sub> ≤ V <sub>CC</sub>	4.5					25	Ω
		I <sub>A</sub> = -24 mA, 0 ≤ V <sub>Bn</sub> ≤ V <sub>CC</sub>	3.0					50	
		I <sub>A</sub> = -8 mA, 0 ≤ V <sub>Bn</sub> ≤ V <sub>CC</sub>	2.3					100	
		I <sub>A</sub> = -4 mA, 0 ≤ V <sub>Bn</sub> ≤ V <sub>CC</sub>	1.65					300	

12. Measured by the voltage drop between A and B pins at the indicated current through the switch. On Resistance is determined by the lower of the voltages on the two (A or B Ports).

13. Guaranteed by Design.

14. For ΔR<sub>ON</sub>, R<sub>FLAT</sub> see -40°C to +85°C section.

APPENDIX A

AC ELECTRICAL EXTENDED AUTOMOTIVE TEMPERATURE RANGE CHARACTERISTICS

Symbol	Parameter	Test Conditions	V <sub>CC</sub> (V)	T <sub>A</sub> = +25°C			T <sub>A</sub> = -55°C to +125°C		Unit	Figure Number
				Min	Typ	Max	Min	Max		
t <sub>PHL</sub> t <sub>PLH</sub>	Propagation Delay Bus to Bus (Note 16)	V <sub>I</sub> = OPEN	1.65–1.95 2.3–2.7 3.0–3.6 4.5–5.5					1.2 0.8 0.3	ns	Figures 2, 3
t <sub>PZL</sub> t <sub>PZH</sub>	Output Enable Time Turn On Time (A to B <sub>n</sub> )	V <sub>I</sub> = 2 × V <sub>CC</sub> for t <sub>PZL</sub> V <sub>I</sub> = 0 V for t <sub>PZH</sub>	1.65–1.95 2.3–2.7 3.0–3.6 4.5–5.5			23 13 6.9 5.2	7.0 3.5 2.5 1.7	24 14 9.0 7.0	ns	Figures 2, 3
t <sub>PLZ</sub> t <sub>PHZ</sub>	Output Disable Time Turn Off Time (A Port to B Port)	V <sub>I</sub> = 2 × V <sub>CC</sub> for t <sub>PLZ</sub> V <sub>I</sub> = 0 V for t <sub>PHZ</sub>	1.65–1.95 2.3–2.7 3.0–3.6 4.5–5.5			12.5 7.0 5.0 3.5	3.0 2.0 1.5 0.8	13 7.5 6.5 5.0	ns	Figures 2, 3
t <sub>B-M</sub>	Break Before Make Time (Note 15)		1.65–1.95 2.3–2.7 3.0–3.6 4.5–5.5				0.5 0.5 0.5 0.5		ns	Figure 4

15. Guaranteed by Design.

16. This parameter is guaranteed by design but not tested. The bus switch contributes no propagation delay other than the RC delay of the On Resistance of the switch and the 50 pF load capacitance, when driven by an ideal voltage source (zero output impedance).

# NLAS3158

## AC LOADING AND WAVEFORMS

NOTE: Input driven by 50 Ω source terminated in 50 Ω  
 NOTE:  $C_L$  includes load and stray capacitance  
 NOTE: Input PRR = 1.0 MHz;  $t_W = 500$  ns

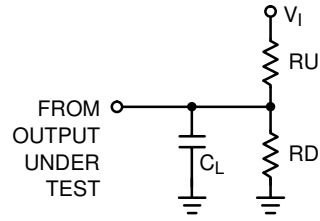

Figure 2. AC Test Circuit

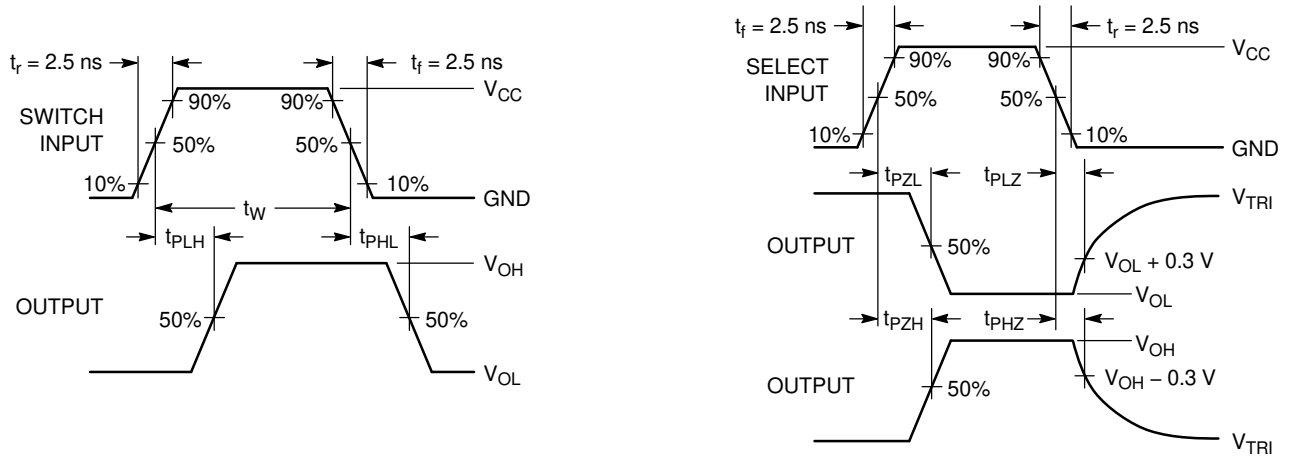

Figure 3. AC Waveforms

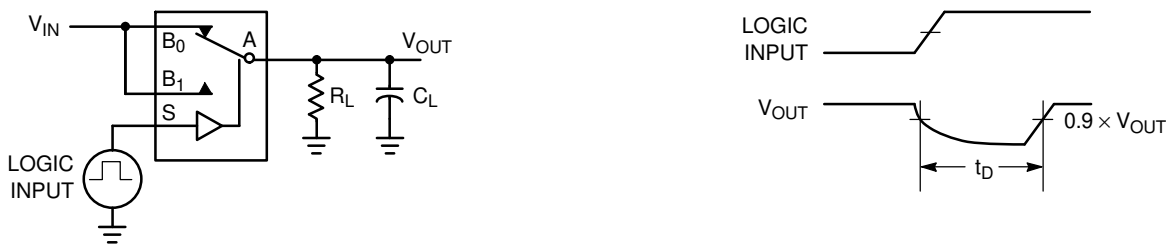
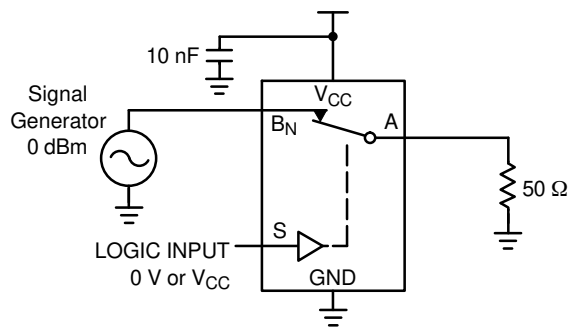
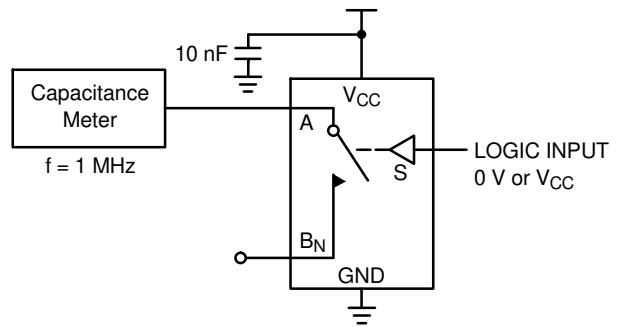
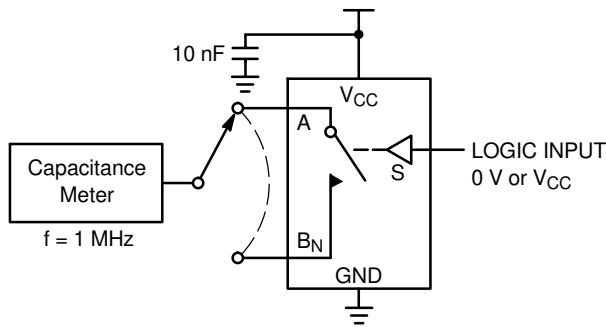
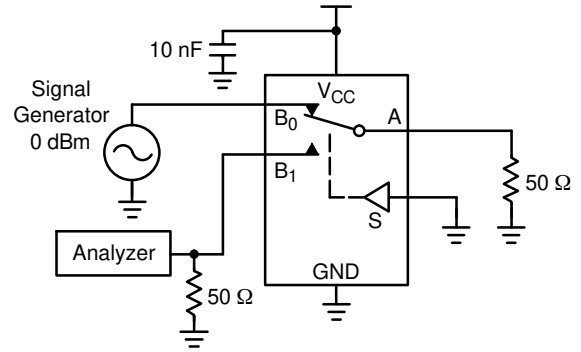
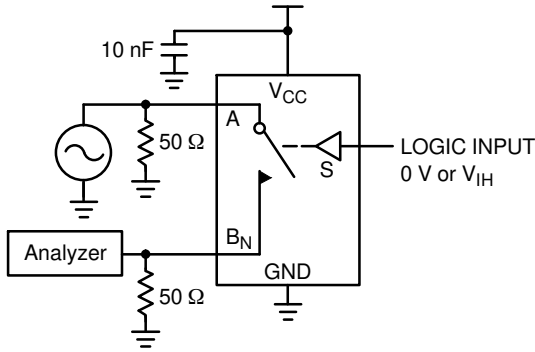
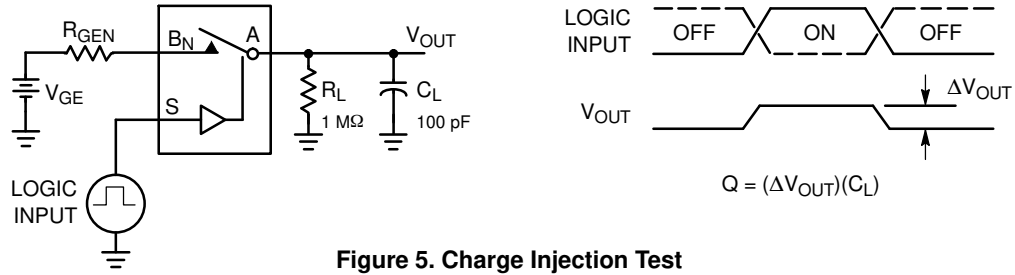

Figure 4. Break Before Make Interval Timing



AC LOADING AND WAVEFORMS



# NLAS3158

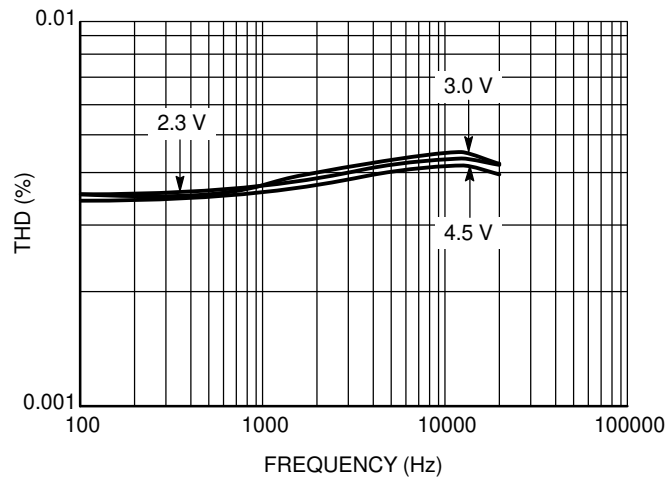

**Figure 11. Total Harmonic Distortion vs. Frequency**

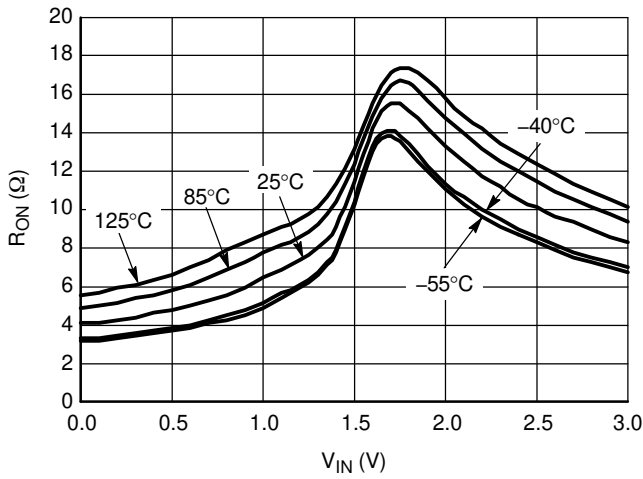

Figure 12.  $R_{ON}$  vs.  $V_{IN}$  vs. Temperature @  $V_{CC} = 3.0\text{ V}$

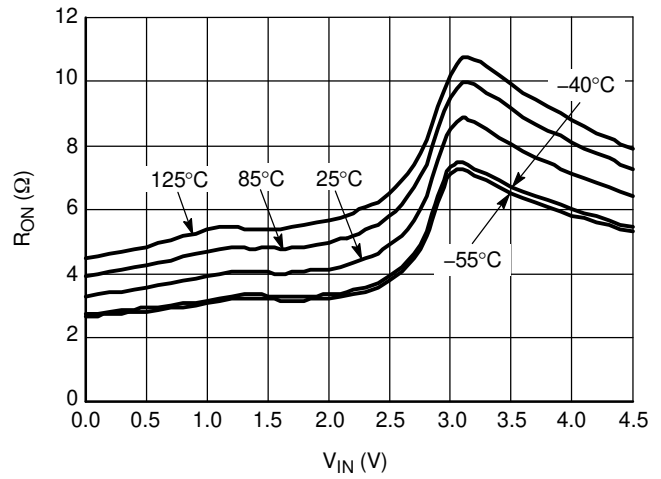

Figure 13.  $R_{ON}$  vs.  $V_{IN}$  vs. Temperature @  $V_{CC} = 4.5\text{ V}$

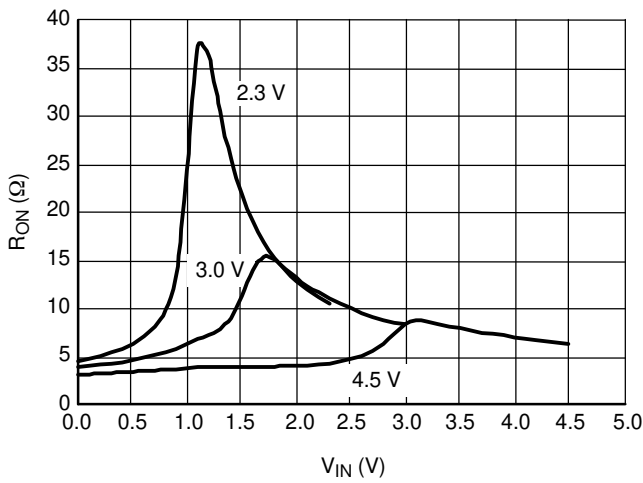

Figure 14. On-Resistance vs. Input Voltage

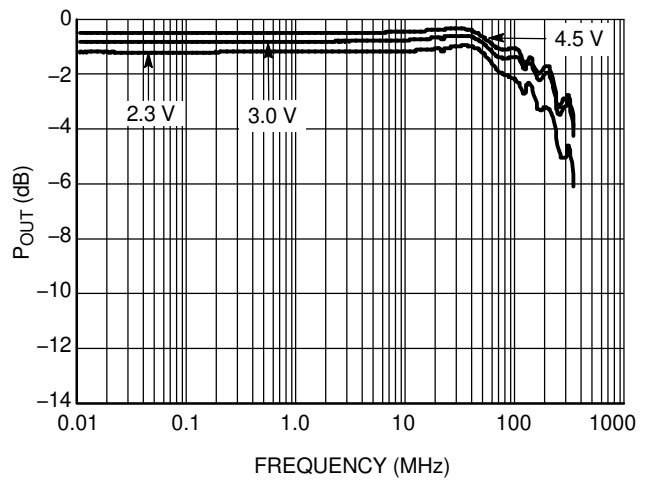

Figure 15. Bandwidth vs. Frequency

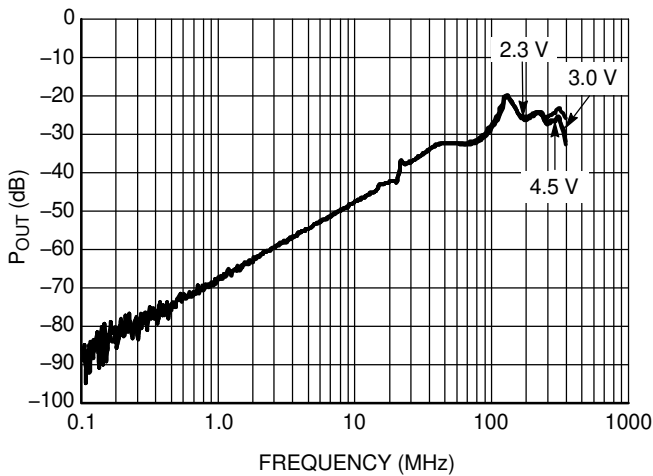

Figure 16. Off-Isolation vs. Frequency

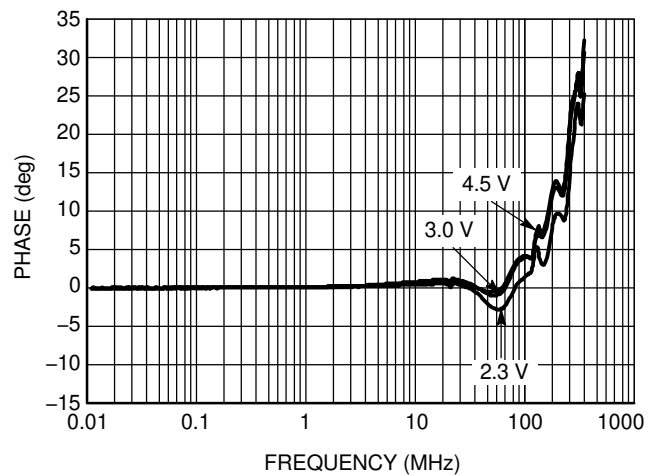

Figure 17. Phase Angle vs. Frequency

# NLAS3158

## DEVICE ORDERING INFORMATION

Device Order Number	Package Type	Tape & Reel Size†
NLAS3158MNR2G	WDFN12 (Pb-Free)	3000 Unit / Reel

†For information on tape and reel specifications, including part orientation and tape sizes, please refer to our Tape and Reel Packaging Specifications Brochure, BRD8011/D.

# NLAS3158

## PACKAGE DIMENSIONS

WDFN12 3.0x1.0, 0.5P  
CASE 485AG  
ISSUE A

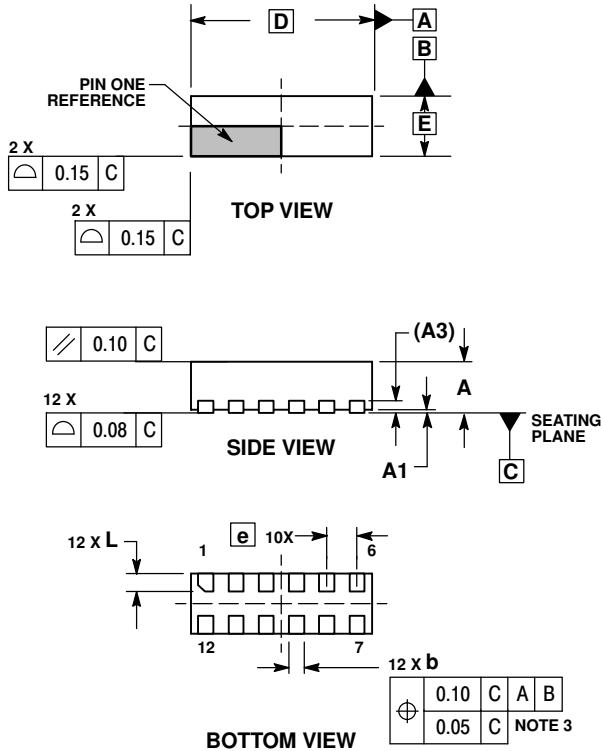

### NOTES:

1. DIMENSIONING AND TOLERANCING PER ASME Y14.5M, 1994.
2. CONTROLLING DIMENSION: MILLIMETER.
3. DIMENSION b APPLIES TO TERMINAL AND IS MEASURED BETWEEN 0.25 AND 0.30 MM FROM TERMINAL.
4. COPLANARITY APPLIES TO THE EXPOSED PAD AS WELL AS THE TERMINALS.

MILLIMETERS		
DIM	MIN	MAX
A	0.70	0.80
A1	0.00	0.05
A3	0.20	REF
b	0.18	0.30
D	3.00	BSC
E	1.00	BSC
e	0.50	BSC
L	0.20	0.40

ON Semiconductor and the are registered trademarks of Semiconductor Components Industries, LLC (SCILLC) or its subsidiaries in the United States and/or other countries. SCILLC owns the rights to a number of patents, trademarks, copyrights, trade secrets, and other intellectual property. A listing of SCILLC's product/patent coverage may be accessed at [www.onsemi.com/site/pdf/Patent-Marking.pdf](http://www.onsemi.com/site/pdf/Patent-Marking.pdf). SCILLC reserves the right to make changes without further notice to any products herein. SCILLC makes no warranty, representation or guarantee regarding the suitability of its products for any particular purpose, nor does SCILLC assume any liability arising out of the application or use of any product or circuit, and specifically disclaims any and all liability, including without limitation special, consequential or incidental damages. "Typical" parameters which may be provided in SCILLC data sheets and/or specifications can and do vary in different applications and actual performance may vary over time. All operating parameters, including "Typicals" must be validated for each customer application by customer's technical experts. SCILLC does not convey any license under its patent rights nor the rights of others. SCILLC products are not designed, intended, or authorized for use as components in systems intended for surgical implant into the body, or other applications intended to support or sustain life, or for any other application in which the failure of the SCILLC product could create a situation where personal injury or death may occur. Should Buyer purchase or use SCILLC products for any such unintended or unauthorized application, Buyer shall indemnify and hold SCILLC and its officers, employees, subsidiaries, affiliates, and distributors harmless against all claims, costs, damages, and expenses, and reasonable attorney fees arising out of, directly or indirectly, any claim of personal injury or death associated with such unintended or unauthorized use, even if such claim alleges that SCILLC was negligent regarding the design or manufacture of the part. SCILLC is an Equal Opportunity/Affirmative Action Employer. This literature is subject to all applicable copyright laws and is not for resale in any manner.

### PUBLICATION ORDERING INFORMATION

**LITERATURE FULFILLMENT:**  
Literature Distribution Center for ON Semiconductor  
19521 E. 32nd Pkwy, Aurora, Colorado 80011 USA  
**Phone:** 303-675-2175 or 800-344-3860 Toll Free USA/Canada  
**Fax:** 303-675-2176 or 800-344-3867 Toll Free USA/Canada  
**Email:** [orderlit@onsemi.com](mailto:orderlit@onsemi.com)

**N. American Technical Support:** 800-282-9855 Toll Free  
USA/Canada  
**Europe, Middle East and Africa Technical Support:**  
Phone: 421 33 790 2910  
**Japan Customer Focus Center**  
Phone: 81-3-5817-1050

**ON Semiconductor Website:** [www.onsemi.com](http://www.onsemi.com)  
**Order Literature:** <http://www.onsemi.com/orderlit>

For additional information, please contact your local Sales Representative