



Chipsmall Limited consists of a professional team with an average of over 10 year of expertise in the distribution of electronic components. Based in Hongkong, we have already established firm and mutual-benefit business relationships with customers from,Europe,America and south Asia,supplying obsolete and hard-to-find components to meet their specific needs.

With the principle of “Quality Parts,Customers Priority,Honest Operation,and Considerate Service”,our business mainly focus on the distribution of electronic components. Line cards we deal with include Microchip,ALPS,ROHM,Xilinx,Pulse,ON,Everlight and Freescale. Main products comprise IC,Modules,Potentiometer,IC Socket,Relay,Connector.Our parts cover such applications as commercial,industrial, and automotives areas.

We are looking forward to setting up business relationship with you and hope to provide you with the best service and solution. Let us make a better world for our industry!



Contact us

Tel: +86-755-8981 8866 Fax: +86-755-8427 6832

Email & Skype: info@chipsmall.com Web: www.chipsmall.com

Address: A1208, Overseas Decoration Building, #122 Zhenhua RD., Futian, Shenzhen, China



NLHV3157N

Negative Voltage SPDT Switch

The NLHV3157N is an advanced CMOS analog switch fabricated with silicon gate CMOS technology. The device passes analog and digital negative voltages that may vary across the full power-supply range (from V_{EE} to GND).

Features

- Operating Voltage Range: $V_{EE} = -12\text{ V to } -4\text{ V}$
- Switch Signal Voltage Range: $V_{IS} = V_{EE}\text{ to GND}$
- Positive Control Signal Voltage: $V_{IN} = 0\text{ to } 3.3\text{ V}$
- Low ON Resistance: $R_{ON} \leq 5\ \Omega @ V_{EE} = -10\text{ V}$
- Latch-up Performance Exceeds 200 mA
- Available in: SC88 6-Pin Package
- These Devices are Pb-Free, Halogen-Free/BFR-Free and are RoHS-Compliant

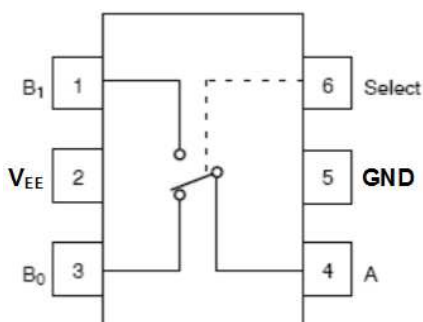
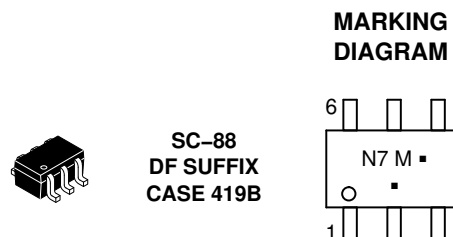

Figure 1. Pin Assignment and logic Diagram



ON Semiconductor®

www.onsemi.com



N7 = Device Code
M = Date Code*
▪ = Pb-Free Package

(Note: Microdot may be in either location)

*Date Code orientation and/or position may vary depending upon manufacturing location.

FUNCTION TABLE

Select Input	Function
L	B0 Connected to A
H	B1 Connected to A

ORDERING INFORMATION

Device	Package	Shipping†
NLHV3157NDFT2G	SC88 (Pb-Free)	3000 / Tape & Reel

†For information on tape and reel specifications, including part orientation and tape sizes, please refer to our Tape and Reel Packaging Specification Brochure, BRD8011/D.

NLHV3157N

MAXIMUM RATINGS

Symbol	Rating	Value	Unit	
V_{EE}	DC Supply Voltage	-13 to +0.5	V	
V_{IS}	Analog Input Voltage (Note 1)	$V_{EE}-0.5$ to +0.5	V	
V_{IN}	Digital Select Input Voltage (Note 1)	-0.5 to +3.6	V	
I_{IOK}	Switch Input/Output diode current	± 50	mA	
I_{IK}	Select input diode current	-50	mA	
P_D	Power Dissipation in Still Air	60	mW	
T_L	Lead Temperature, 1 mm from Case for 10 seconds	260	$^{\circ}\text{C}$	
T_J	Junction Bias Under Bias	150	$^{\circ}\text{C}$	
MSL	Moisture Sensitivity	Level 1		
F_R	Flammability Rating	Oxygen Index: 30% – 35% UL94-V0 (0.125 in)	$^{\circ}\text{C}$	
I_L	Latch-up Current (Note1)	Below GND and above V_{EE} at 125 $^{\circ}\text{C}$	± 200	mA
		Below GND and above V_{EE} at 25 $^{\circ}\text{C}$	± 300	
T_s	Storage Temperature	-65 to +150	$^{\circ}\text{C}$	
θ_{JA}	Thermal Resistance	400	$^{\circ}\text{C}/\text{W}$	
ESD	ESD Protection	Human Body Model	3000	V
		Machine Model	150	

Stresses exceeding those listed in the Maximum Ratings table may damage the device. If any of these limits are exceeded, device functionality should not be assumed, damage may occur and reliability may be affected.

1. The input and output voltage ratings may be exceeded if the input and output diode current ratings are observed.

RECOMMENDED OPERATING CONDITIONS (Note 2)

Symbol	Parameter	Min	Max	Unit
V_{EE}	DC Supply Voltage	-12	-4	V
V_S	Switch Input / Output Voltage (B0, B1, A)	V_{EE}	GND	V
V_{IN}	Digital Select Input Voltage	GND	3.3	V
T_A	Operating Temperature Range	-55	+125	$^{\circ}\text{C}$
t_r, t_f	Input Transition Rise or Fall Time (Select Input)	0	100	ns/V

Functional operation above the stresses listed in the Recommended Operating Ranges is not implied. Extended exposure to stresses beyond the Recommended Operating Ranges limits may affect device reliability.

2. Select input must be held HIGH or LOW, it must not float.

NLHV3157N

DC ELECTRICAL CHARACTERISTICS (Voltages referenced to GND; Typical characteristics are T_A at 25°C.)

Symbol	Parameter	Condition	V_{EE} , V	-55° to 125°C			Unit
				Min	Typ	Max	
SELECT INPUT							
V_{IH}	Minimum High-Level Input Voltage		< -10	2.0		3.3	V
			-10 to < -8	1.8		3.3	
			-8 to < -6	1.7		3.3	
			≥ -6	1.4		3.3	
V_{IL}	Maximum Low-Level Input Voltage		< -10	0		0.7	V
			-10 to < -6	0		0.7	
			-8 to < -6	0		0.7	
			≥ -6	0		0.5	
I_{IN}	Maximum Input Leakage Current	$V_{IN} = 3.3$ V or GND	-10		± 0.2	± 20	μ A

POWER SUPPLY

I_{CC}	Maximum Quiescent Supply Current	Select = 3.3 V or GND, $V_{IS} = V_{EE}$ or GND	-10 to -4		25	50	μ A
----------	----------------------------------	--	-----------	--	----	----	---------

ANALOG SWITCH

R_{ON}	Maximum ON Resistance (Note 3)	$V_{IN} = V_{IL}$ or V_{IH} $V_{IS} = V_{EE}$ to GND $I_O \leq 10$ mA	-12		2.6	4.5	Ω
			-10		3.0	5	
			-8		3.5	5.8	
			-6		4.5	7.5	
		$V_{IN} = V_{IL}$ or V_{IH} $V_{IS} = V_{EE}$ to GND $I_O \leq 5$ mA	-4		9	15	
R_{FLAT}	ON Resistance Flatness (Notes 3, 4, 6)	$V_{IN} = V_{IL}$ or V_{IH} $V_{IS} = V_{EE}$ to GND $I_O \leq 10$ mA	-12		0.4		Ω
			-10		1.2		
			-8		1.7		
			-6		2.5		
		$V_{IN} = V_{IL}$ or V_{IH} $V_{IS} = V_{EE}$ to GND $I_O \leq 5$ mA	-4		6		
ΔR_{ON}	R_{ON} Mismatch Between (Notes 3, 4, 5)	$I_A = -10$ mA, $V_{Bn} = -8.4$ V	-12		0.2		Ω
		$I_A = -10$ mA, $V_{Bn} = -7$ V	-10		0.2		
		$I_A = -10$ mA, $V_{Bn} = -5.6$ V	-8		0.25		
		$I_A = -10$ mA, $V_{Bn} = -4.2$ V	-6		0.25		
		$I_A = -5$ mA, $V_{Bn} = -2.8$ V	-4		0.3		
$I_{NC(OFF)}$, $I_{NO(OFF)}$	NC or NO OFF Leakage Current (Figure 9)	$V_{IN} = V_{IL}$ or V_{IH} , $V_{Bn} =$ GND, $V_A = V_{EE}$ to GND	-10		± 1.0	± 20	μ A
$I_{COM(ON)}$	COM ON Leakage Current (Figure 9)	$V_{IN} = V_{IL}$ or V_{IH} ; $V_A =$ GND V or V_{EE} ; $V_{B1} =$ GND or V_{EE} with V_{B0} floating, or $V_{B0} =$ GND or V_{EE} with V_{B1} floating	-10		± 2.0	± 20	μ A

Product parametric performance is indicated in the Electrical Characteristics for the listed test conditions, unless otherwise noted. Product performance may not be indicated by the Electrical Characteristics if operated under different conditions.

3. Measured by the voltage drop between A and B pins at the indicated current through the switch. On Resistance is determined by the lower of the voltages on the two (A or B Ports).

4. Parameter is characterized but not tested in production.

5. $\Delta R_{ON} = R_{ONmax} - R_{ONmin}$ measured at identical V_{EE} , temperature and voltage levels.

6. Flatness is defined as the difference between the maximum and minimum value of ON Resistance over the specified range of conditions.

NLHV3157N

AC ELECTRICAL CHARACTERISTICS (Voltages referenced to GND; Typical characteristics are T_A at 25°C.)

Symbol	Parameter	Condition	V_{EE} , V	-55° to 125°C			Unit
				Min	Typ	Max	
t_{PHL} , t_{PLH}	Propagation Delay, Bus to Bus (Note 8) (A to B_n)	$C_L = 100$ pF (Figures 2, 3)	-12 to -4			2	ns
t_{PZL} , t_{PZH}	Switch Enable Time Turn-On Time (A to B_n)	$C_L = 100$ pF (Figures 2, 3)	-12			220	ns
			-10			175	
			-8			165	
			-6			165	
			-4			200	
t_{PLZ} , t_{PHZ}	Switch Disable Time Turn-Off Time (A to B_n)	$C_L = 100$ pF (Figures 2, 3)	-12			225	ns
			-10			155	
			-8			150	
			-6			120	
			-4			145	
t_B	Switch Break Time	$R_L = 50$ Ω , $C_L = 100$ pF, $V_{IS} = -2.5$ V (Figure 4)	-12	10		50	ns
			-10	10		60	
			-8	20		75	
			-6	20		90	
			-4	50		135	
t_{POR}	Power ON Reset Time	Measured from $V_{EE} = -4$ V	-12 to -4			20	μ s
Q	Charge Injection (Note 7)	$C_L = 1$ nF, $V_{GEN} = 0$ V, $R_{GEN} = 0$ Ω (Figure 5)	-12			170	pC
			-10			120	
			-8			95	
			-6			55	
			-4			40	
OIRR	Off-Isolation (Note 9)	$R_L = 50$ Ω , $f = 10$ MHz (Figure 6)	-12 to -4		-33		dB
Xtalk	Crosstalk	$R_L = 50$ Ω , $f = 10$ MHz (Figure 7)	-12 to -4		-42		dB
BW	-3 dB Bandwidth	$R_L = 50$ Ω (Figure 10)	-12 to -4		200		MHz

7. Guaranteed by Design.

8. This parameter is guaranteed by design but not tested. The bus switch contributes no propagation delay other than the RC delay of the ON Resistance of the switch and the 50 pF load capacitance, when driven by an ideal voltage source (zero output impedance).

9. Off Isolation = $20 \log_{10} [V_A/V_{Bn}]$.

CAPACITANCES (Note 10)

Symbol	Parameter	Test Conditions	Typical @ 25°C	Unit
C_{IN}	Input Capacitance, Select Inputs	$V_{EE} = -12$ V	6	pF
C_{IOB}	B-Port OFF Capacitance	$V_{EE} = -10$ V	45	pF
C_{IOA_ON}	A Port Capacitance when Switch is Enabled	$V_{EE} = -10$ V	100	pF

10. $T_A = +25^\circ\text{C}$, $f = 1$ MHz, Capacitance is characterized but not tested in production.

NLHV3157N

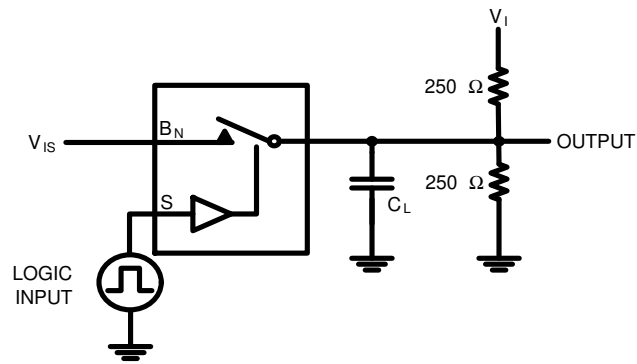

Note: Input V_{IS} driven by $50\ \Omega$ source terminated by $50\ \Omega$.
Note: C_L includes load and stray capacitance.
 Input PRR = 100 kHz, $t_W = 5\ \mu\text{s}$.

Parameter	V_I	V_{IS}
t_{PLH} / t_{PHL}	Open	Source
t_{PZL} / t_{PLZ}	GND	V_{EE}
t_{PZH} / t_{PHZ}	$2 \times V_{EE}$	GND

Figure 2. AC Test Circuit

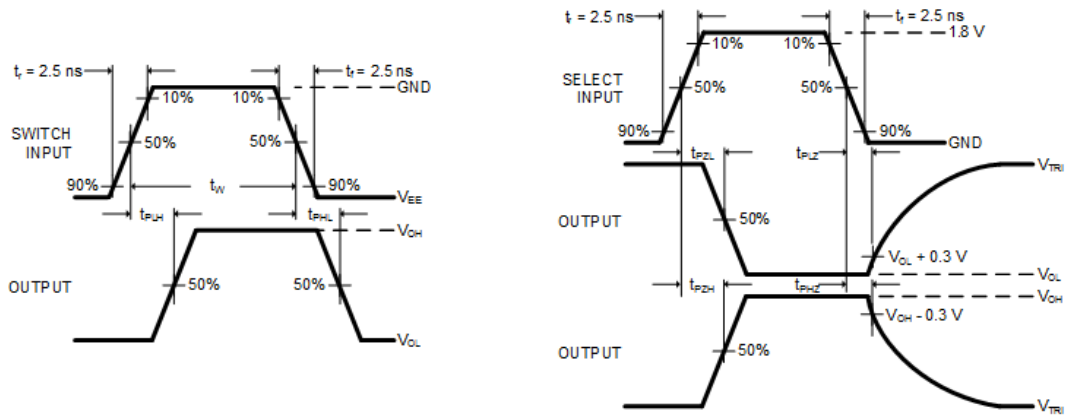

Figure 3. AC Test Waveforms

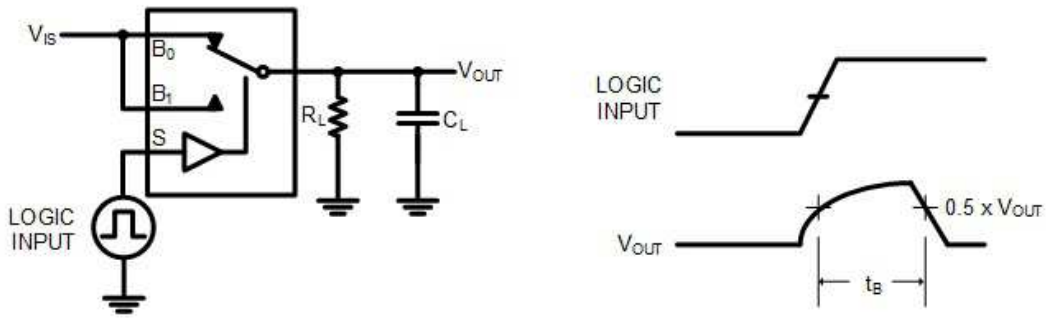

Figure 4. Switch Break Interval Timing

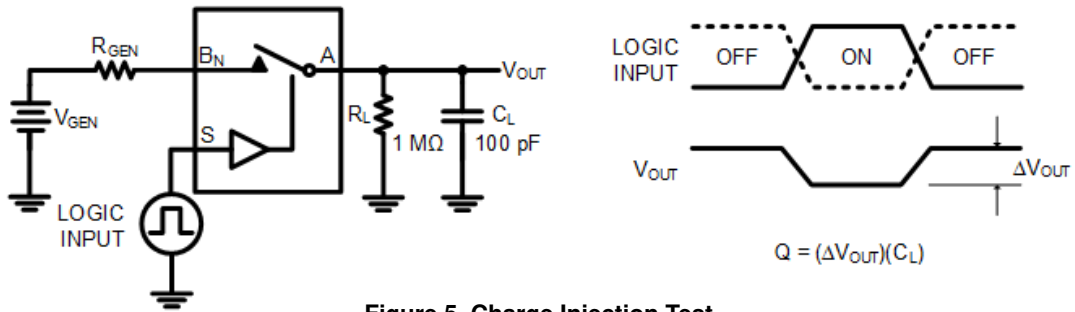

Figure 5. Charge Injection Test

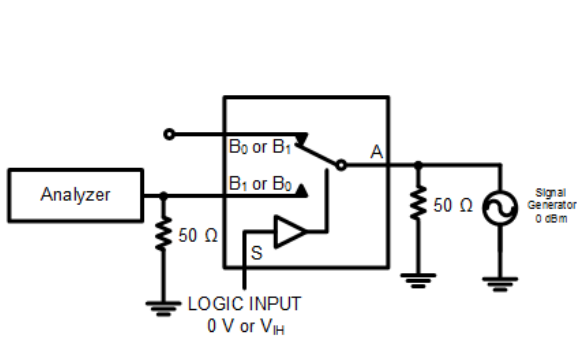

Figure 6. Off Isolation

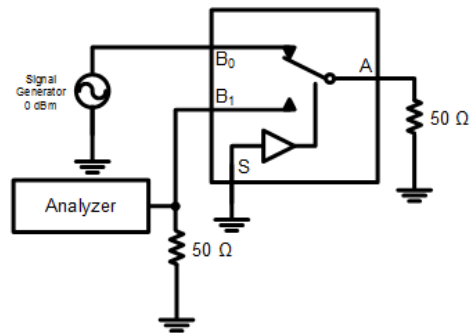

Figure 7. Crosstalk

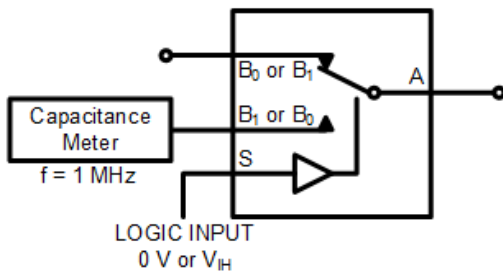

Figure 8. Channel Off Capacitance

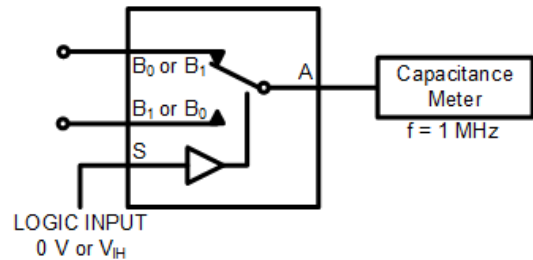
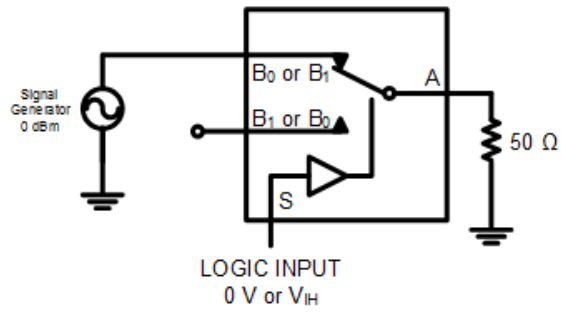

Figure 9. Channel On Capacitance

NLHV3157N



$$BW = \frac{0.707 \cdot VA}{VBn}, \quad n = 0 \text{ or } 1$$

Figure 10. Bandwidth

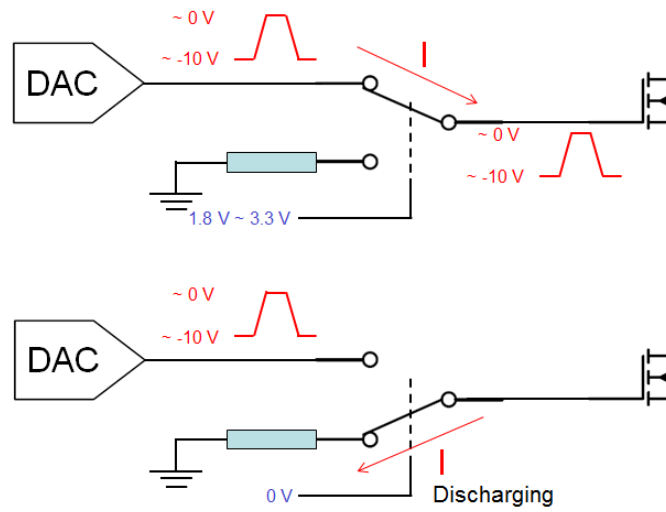
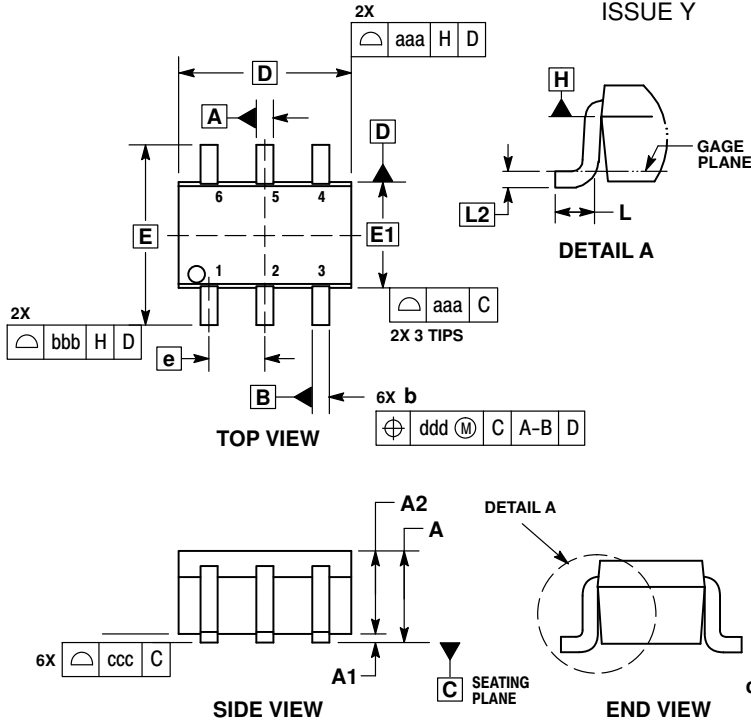

Figure 11. Typical Application

NLHV3157N

PACKAGE DIMENSIONS

SC-88/SC70-6/SOT-363
CASE 419B-02
ISSUE Y



- NOTES:
1. DIMENSIONING AND TOLERANCING PER ASME Y14.5M, 1994.
 2. CONTROLLING DIMENSION: MILLIMETERS.
 3. DIMENSIONS D AND E1 DO NOT INCLUDE MOLD FLASH, PROTRUSIONS, OR GATE BURRS. MOLD FLASH, PROTRUSIONS, OR GATE BURRS SHALL NOT EXCEED 0.20 PER END.
 4. DIMENSIONS D AND E1 AT THE OUTERMOST EXTREMES OF THE PLASTIC BODY AND DATUM H.
 5. DATUMS A AND B ARE DETERMINED AT DATUM H.
 6. DIMENSIONS b AND c APPLY TO THE FLAT SECTION OF THE LEAD BETWEEN 0.08 AND 0.15 FROM THE TIP.
 7. DIMENSION b DOES NOT INCLUDE DAMBAR PROTRUSION. ALLOWABLE DAMBAR PROTRUSION SHALL BE 0.08 TOTAL IN EXCESS OF DIMENSION b AT MAXIMUM MATERIAL CONDITION. THE DAMBAR CANNOT BE LOCATED ON THE LOWER RADIUS OF THE FOOT.

DIM	MILLIMETERS			INCHES		
	MIN	NOM	MAX	MIN	NOM	MAX
A	---	---	1.10	---	---	0.043
A1	0.00	---	0.10	0.000	---	0.004
A2	0.70	0.90	1.00	0.027	0.035	0.039
b	0.15	0.20	0.25	0.006	0.008	0.010
C	0.08	0.15	0.22	0.003	0.006	0.009
D	1.80	2.00	2.20	0.070	0.078	0.086
E	2.00	2.10	2.20	0.078	0.082	0.086
E1	1.15	1.25	1.35	0.045	0.049	0.053
e	0.65 BSC			0.026 BSC		
L	0.26	0.36	0.46	0.010	0.014	0.018
L2	0.15 BSC			0.006 BSC		
aaa	0.15			0.006		
bbb	0.30			0.012		
ccc	0.10			0.004		
ddd	0.10			0.004		

RECOMMENDED SOLDERING FOOTPRINT*

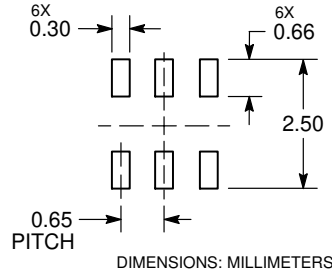

*For additional information on our Pb-Free strategy and soldering details, please download the ON Semiconductor Soldering and Mounting Techniques Reference Manual, SOLDERRM/D.

ON Semiconductor and the are registered trademarks of Semiconductor Components Industries, LLC (SCILLC) or its subsidiaries in the United States and/or other countries. SCILLC owns the rights to a number of patents, trademarks, copyrights, trade secrets, and other intellectual property. A listing of SCILLC's product/patent coverage may be accessed at www.onsemi.com/site/pdf/Patent-Marketing.pdf. SCILLC reserves the right to make changes without further notice to any products herein. SCILLC makes no warranty, representation or guarantee regarding the suitability of its products for any particular purpose, nor does SCILLC assume any liability arising out of the application or use of any product or circuit, and specifically disclaims any and all liability, including without limitation special, consequential or incidental damages. "Typical" parameters which may be provided in SCILLC data sheets and/or specifications can and do vary in different applications and actual performance may vary over time. All operating parameters, including "Typicals" must be validated for each customer application by customer's technical experts. SCILLC does not convey any license under its patent rights nor the rights of others. SCILLC products are not designed, intended, or authorized for use as components in systems intended for surgical implant into the body, or other applications intended to support or sustain life, or for any other application in which the failure of the SCILLC product could create a situation where personal injury or death may occur. Should Buyer purchase or use SCILLC products for any such unintended or unauthorized application, Buyer shall indemnify and hold SCILLC and its officers, employees, subsidiaries, affiliates, and distributors harmless against all claims, costs, damages, and expenses, and reasonable attorney fees arising out of, directly or indirectly, any claim of personal injury or death associated with such unintended or unauthorized use, even if such claim alleges that SCILLC was negligent regarding the design or manufacture of the part. SCILLC is an Equal Opportunity/Affirmative Action Employer. This literature is subject to all applicable copyright laws and is not for resale in any manner.

PUBLICATION ORDERING INFORMATION

LITERATURE FULFILLMENT:
Literature Distribution Center for ON Semiconductor
19521 E. 32nd Pkwy, Aurora, Colorado 80011 USA
Phone: 303-675-2175 or 800-344-3860 Toll Free USA/Canada
Fax: 303-675-2176 or 800-344-3867 Toll Free USA/Canada
Email: orderlit@onsemi.com

N. American Technical Support: 800-282-9855 Toll Free
USA/Canada
Europe, Middle East and Africa Technical Support:
Phone: 421 33 790 2910
Japan Customer Focus Center
Phone: 81-3-5817-1050

ON Semiconductor Website: www.onsemi.com
Order Literature: <http://www.onsemi.com/orderlit>
For additional information, please contact your local Sales Representative