



Chipsmall Limited consists of a professional team with an average of over 10 year of expertise in the distribution of electronic components. Based in Hongkong, we have already established firm and mutual-benefit business relationships with customers from,Europe,America and south Asia,supplying obsolete and hard-to-find components to meet their specific needs.

With the principle of “Quality Parts,Customers Priority,Honest Operation,and Considerate Service”,our business mainly focus on the distribution of electronic components. Line cards we deal with include Microchip,ALPS,ROHM,Xilinx,Pulse,ON,Everlight and Freescale. Main products comprise IC,Modules,Potentiometer,IC Socket,Relay,Connector.Our parts cover such applications as commercial,industrial, and automotives areas.

We are looking forward to setting up business relationship with you and hope to provide you with the best service and solution. Let us make a better world for our industry!



## Contact us

Tel: +86-755-8981 8866 Fax: +86-755-8427 6832

Email & Skype: info@chipsmall.com Web: www.chipsmall.com

Address: A1208, Overseas Decoration Building, #122 Zhenhua RD., Futian, Shenzhen, China



### General Description

- NMSD200B01 is best suited for switching voltage regulator and power management applications. It improves efficiency and reliability of DC-DC controllers used in Voltage Regulator Modules (VRM) and can support continuous maximum current of 200mA. It features an ESD protected discrete N-MOSFET with low on-resistance and a discrete Schottky diode with low forward drop. It reduces component count, consumes less space and minimizes parasitic losses. The component devices can be used as a part of a circuit or as a stand alone discrete device.

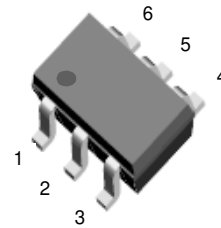

Fig 1. SOT-363

### Features

- N-MOSFET with ESD Gate Protection
- N-MOSFET with Low On-Resistance ( $R_{DS(ON)}$ )
- Low  $V_f$  Schottky Diode
- Low Static, Switching and Conduction Losses
- Good Dynamic Performance
- Surface Mount Package Suited for Automated Assembly
- Lead Free By Design/RoHS Compliant (Note 1)**
- "Green" Device (Note 2)**

### Mechanical Data

- Case: SOT-363
- Case Material: Molded Plastic. "Green Molding" Compound. UL Flammability Classification Rating 94V-0
- Moisture Sensitivity: Level 1 per J-STD-020D
- Terminal Connections: See Diagram
- Terminals: Finish - Matte Tin annealed over Alloy 42 leadframe. Solderable per MIL-STD-202, Method 208
- Marking & Type Code Information: See Page 7
- Ordering Information: See Last Page
- Weight: 0.006 grams (approximate)

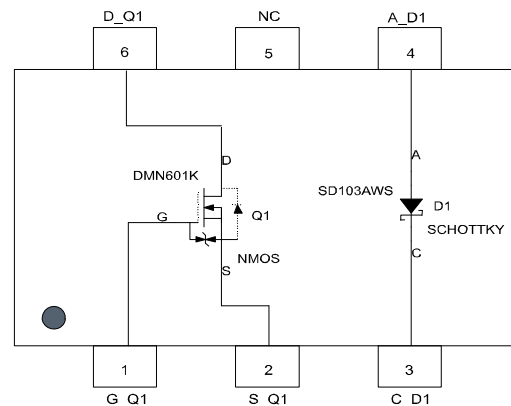

Fig 2. Schematic and Pin Configuration

Sub-Components	Reference	Device Type	Figure
DMN601K DIE (ESD Protected)	Q1	N-MOSFET	2
SD103AWS DIE	D1	Schottky Diode	2

### Maximum Ratings, Total Device @ $T_A = 25^\circ\text{C}$ unless otherwise specified

Characteristic	Symbol	Value	Unit
Power Dissipation (Note 3)	$P_d$	200	mW
Power Derating Factor above 25 °C	$P_{der}$	1.6	mW/°C
Output Current	$I_{out}$	200	mA

### Thermal Characteristics

Characteristic	Symbol	Value	Unit
Junction Operation and Storage Temperature Range	$T_j, T_{stg}$	-55 to +150	°C
Thermal Resistance, Junction to Ambient Air (Note 3) (Equivalent to one heated junction of N-MOSFET)	$R_{\theta JA}$	625	°C/W

- Notes:
- No purposefully added lead.
  - Diodes Inc.'s "Green" policy can be found on our website at [http://www.diodes.com/products/lead\\_free/index.php](http://www.diodes.com/products/lead_free/index.php).
  - Device mounted on FR-4 PCB, 1 inch x 0.85 inch x 0.062 inch; pad layout as shown on Diodes Inc. suggested pad layout document AP02001, which can be found on our website at <http://www.diodes.com/datasheets/ap02001.pdf>.



**Maximum Ratings:** @T<sub>A</sub> = 25°C unless otherwise specified

**Sub-Component Device: ESD Protected N-Channel MOSFET (Q1)**

Characteristic	Symbol	Value	Unit
Drain Source Voltage	V <sub>DSS</sub>	60	V
Drain Gate Voltage (RGS <+ 1MΩm)	V <sub>DGR</sub>	60	V
Gate Source Voltage	V <sub>GSS</sub>	Continuous	+/-20
		Pulsed (tp<50 uS)	+/-40
Drain Current (Page 1: Note 3)	I <sub>D</sub>	Continuous (V <sub>gs</sub> =10V)	200
		Pulsed (tp<10uS, Duty Cycle<1%)	800
Continuous Source Current	I <sub>S</sub>	200	mA

**Sub-Component Device: Schottky Diode (D1)** @T<sub>A</sub> = 25°C unless otherwise specified

Characteristic	Symbol	Value	Unit
Peak Repetitive Reverse Voltage	V <sub>RRM</sub>	40	V
Working Peak Reverse Voltage	V <sub>RWM</sub>		
DC Blocking Voltage	V <sub>R</sub>		
RMS Reverse Voltage	V <sub>R(RMS)</sub>	28	V
Forward Continuous Current (Page 1: Note 3)	I <sub>FM</sub>	350	mA
Non-Repetitive Peak Forward Surge Current @ t<1.0 s	I <sub>FSM</sub>	1.5	A

**Electrical Characteristics:**

**ESD Protected N-Channel MOSFET (Q1)** @T<sub>A</sub> = 25°C unless otherwise specified

Characteristic	Symbol	Min	Typ	Max	Unit	Test Condition
<b>OFF CHARACTERISTICS (Note 4)</b>						
Drain-Source Breakdown Voltage, BV <sub>DSS</sub>	V <sub>BR(DSS)</sub>	60	—	—	V	V <sub>GS</sub> = 0V, I <sub>D</sub> = 10μA
Zero Gate Voltage Drain Current (Drain Leakage Current)	I <sub>DSS</sub>	—	—	1	μA	V <sub>GS</sub> = 0V, V <sub>DS</sub> = 60V
Gate Body Leakage Current, Forward	I <sub>GSSF</sub>	—	—	10	μA	V <sub>GS</sub> = 20V, V <sub>DS</sub> = 0V
Gate Body Leakage Current, Reverse	I <sub>GSSR</sub>	—	—	-10	μA	V <sub>GS</sub> = -20 V, V <sub>DS</sub> = 0V
<b>ON CHARACTERISTICS (Note 4)</b>						
Gate Source Threshold Voltage (Control Supply Voltage)	V <sub>GS(th)</sub>	1	1.6	2.5	V	V <sub>DS</sub> = V <sub>GS</sub> = 10V, I <sub>D</sub> = 0.25mA
		1.1	1.8	3	V	V <sub>DS</sub> = V <sub>GS</sub> = 10V, I <sub>D</sub> = 1mA
Static Drain-Source On-State Voltage	V <sub>DS(on)</sub>	—	0.09	1.5	V	V <sub>GS</sub> = 5V, I <sub>D</sub> = 50mA
		—	0.62	1.25	V	V <sub>GS</sub> = 10V, I <sub>D</sub> = 500mA
On-State Drain Current	I <sub>D(on)</sub>	500	—	—	mA	V <sub>GS</sub> = 10V, V <sub>DS</sub> >= 2*V <sub>DS(ON)</sub>
Static Drain-Source On Resistance	R <sub>DS(on)</sub>	—	1.6	3	Ω	V <sub>GS</sub> = 5V, I <sub>D</sub> = 50mA
		—	1.25	2	Ω	V <sub>GS</sub> = 10V, I <sub>D</sub> = 500mA
Forward Transconductance	g <sub>FS</sub>	80	260	—	mS	V <sub>DS</sub> >= 2*V <sub>DS(ON)</sub> , I <sub>D</sub> = 200mA
<b>Dynamic Characteristics</b>						
Input Capacitance	C <sub>iss</sub>	—	—	50	pF	V <sub>DS</sub> = 25V, V <sub>GS</sub> = 0V, f = 1MHz
Output Capacitance	C <sub>oss</sub>	—	—	25	pF	
Reverse Transfer Capacitance	C <sub>rss</sub>	—	—	5	pF	
<b>Switching Characteristics</b>						
Turn-On Delay Time	t <sub>d(on)</sub>	—	—	20	ns	—
Turn-Off Delay Time	t <sub>d(off)</sub>	—	—	40	ns	—
<b>Drain-Source (Body) Diode Characteristics and Maximum Ratings</b>						
Drain-Source Diode Forward On-Voltage	V <sub>SD</sub>	—	0.88	1.5	V	V <sub>GS</sub> = 0V, I <sub>S</sub> = 300 mA*
Maximum Continuous Drain-Source Diode Forward Current (Reverse Drain Current)	I <sub>S</sub>	—	—	300	mA	—
Maximum Pulsed Drain-Source Diode Forward Current	I <sub>SM</sub>	—	—	800	mA	—

**Electrical Characteristics: Schottky Barrier Diode (D1)** @T<sub>A</sub> = 25°C unless otherwise specified

Characteristic	Symbol	Min	Typ	Max	Unit	Test Condition
Reverse Breakdown Voltage (Note 4)	V <sub>(BR)R</sub>	40	—	—	V	I <sub>R</sub> = 10μA
Forward Voltage Drop (Note 4)	V <sub>FM</sub>	—	—	0.37	V	I <sub>F</sub> = 20mA
		—	—	0.6	V	I <sub>F</sub> = 200mA
Peak Reverse Current (Note 4)	I <sub>RM</sub>	—	—	5	μA	V <sub>R</sub> = 30V
Total Capacitance	C <sub>T</sub>	—	28	—	pF	V <sub>R</sub> = 0V, f = 1.0 MHz
Reverse Recovery Time	t <sub>rr</sub>	—	10	—	ns	I <sub>F</sub> = I <sub>R</sub> = 200 mA, I <sub>rr</sub> = 0.1xI <sub>R</sub> , R <sub>L</sub> = 100 Ω

Notes: 4. Short duration pulse test used to minimize self-heating effect.

## Typical Characteristics

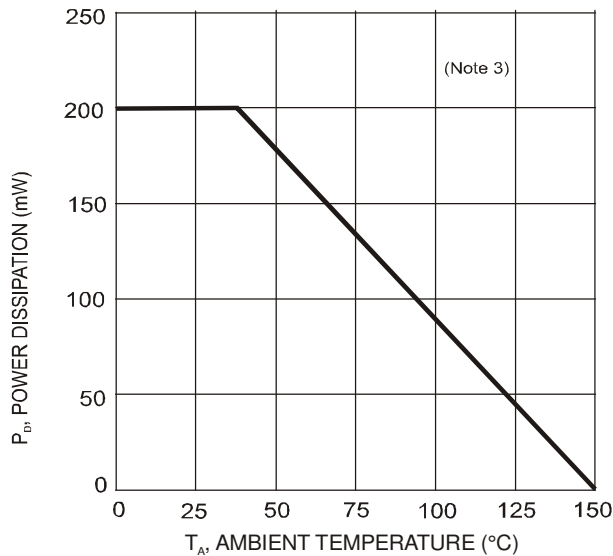

Fig. 3, Max Power Dissipation vs. Ambient Temperature

## Typical N-Channel MOSFET-Q1 (ESD Protected) Characteristics

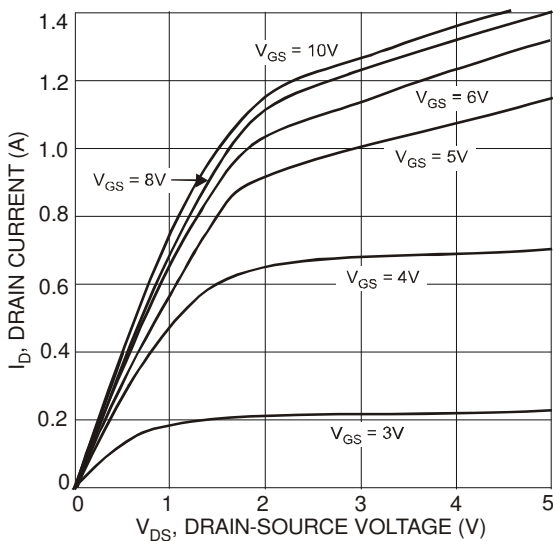

Fig. 4 Output Characteristics

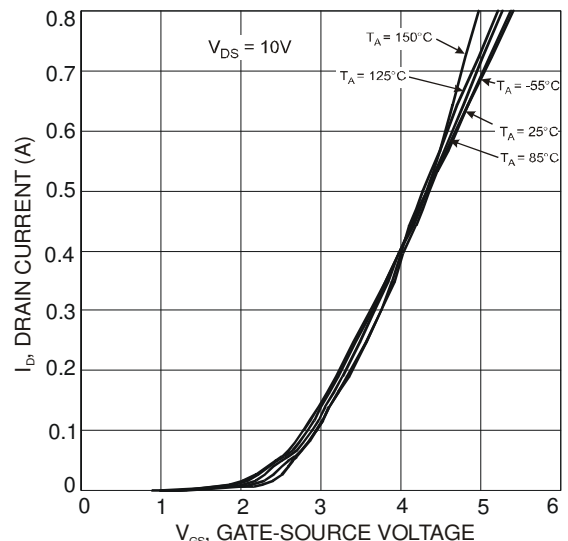

Fig. 5 Transfer Characteristics

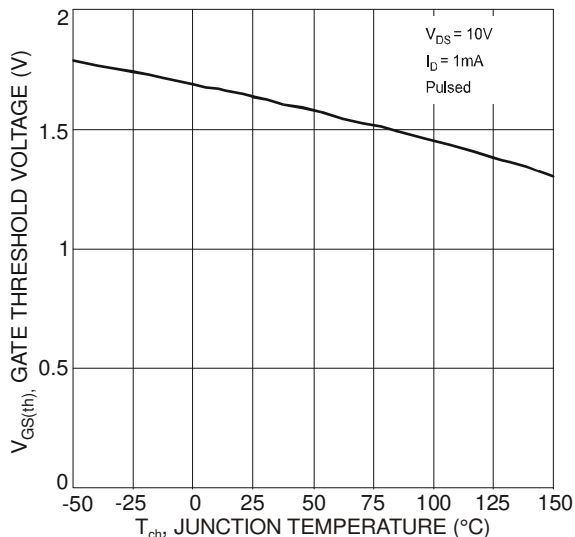

Fig. 6 Gate Threshold Voltage vs. Junction Temperature

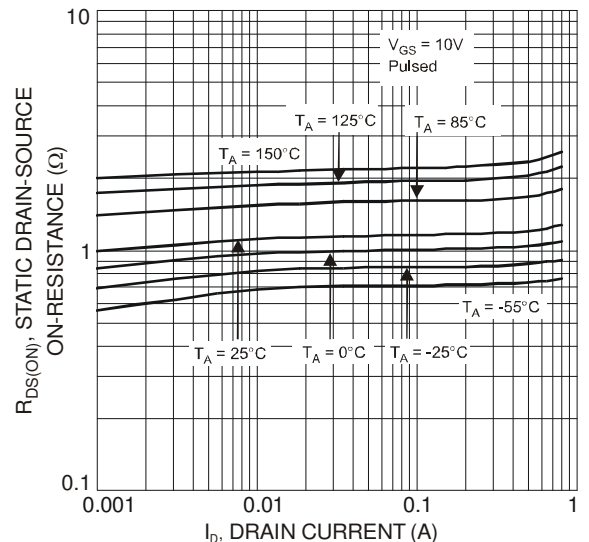

Fig. 7 Static Drain-Source On-Resistance vs. Drain Current

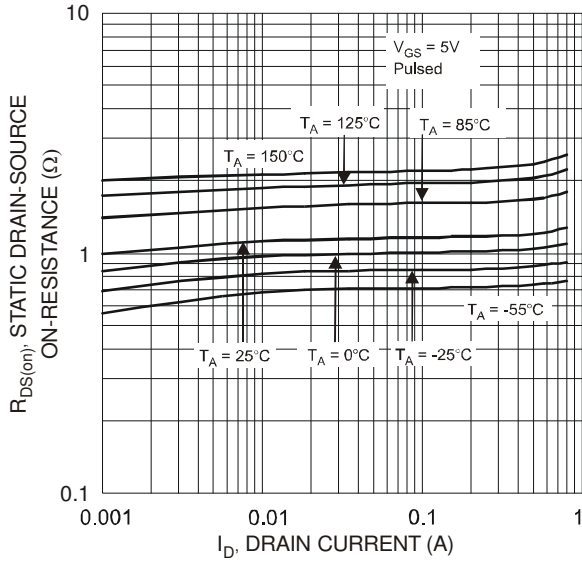

Fig. 8 Static Drain-Source On-Resistance vs. Drain Current

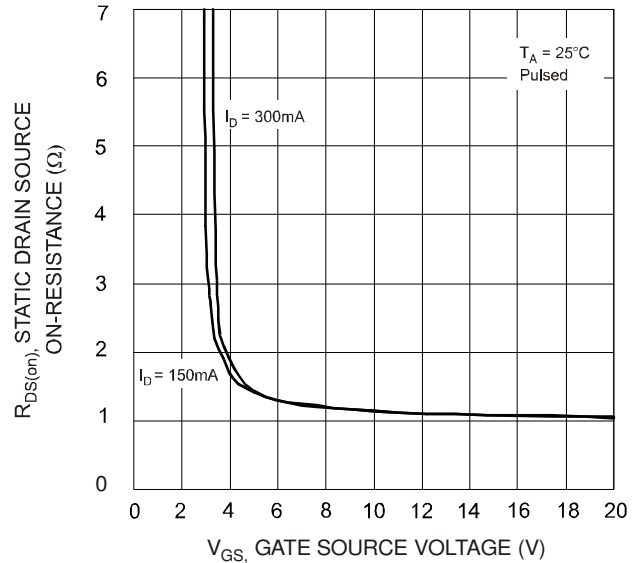

Fig. 9 Static Drain-Source On-Resistance vs. Gate-Source Voltage

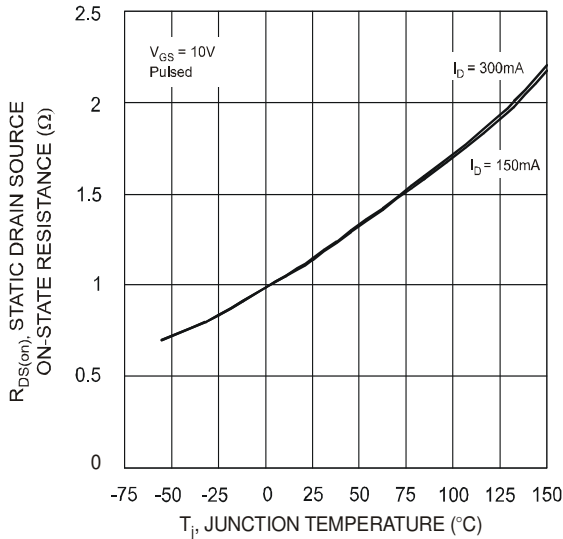

Fig. 10 Static Drain-Source On-State Resistance vs. Junction Temperature

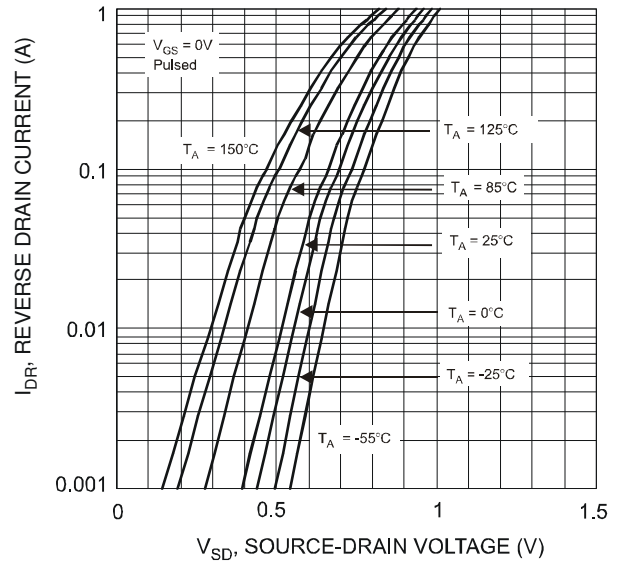

Fig. 11 Reverse Drain Current vs. Source-Drain Voltage

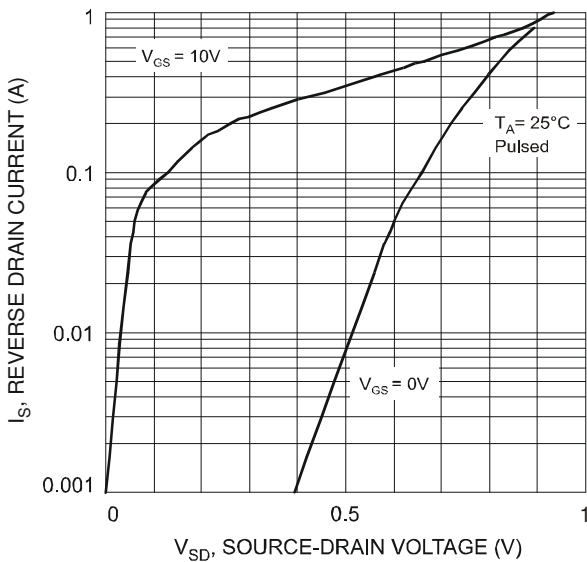

Fig. 12 Reverse Drain Current vs. Body Diode Forward Voltage

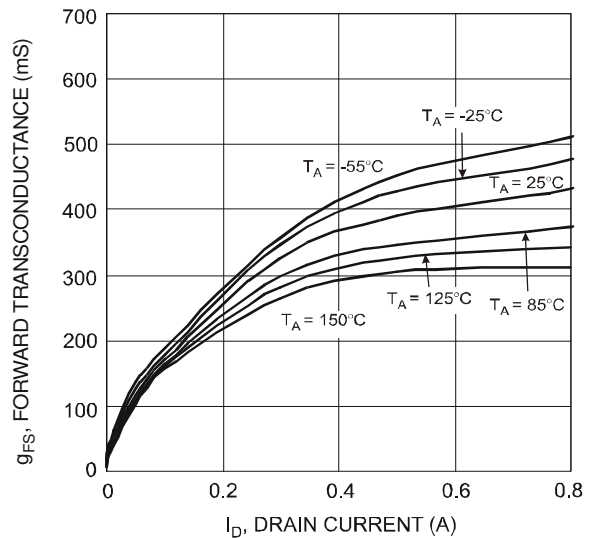
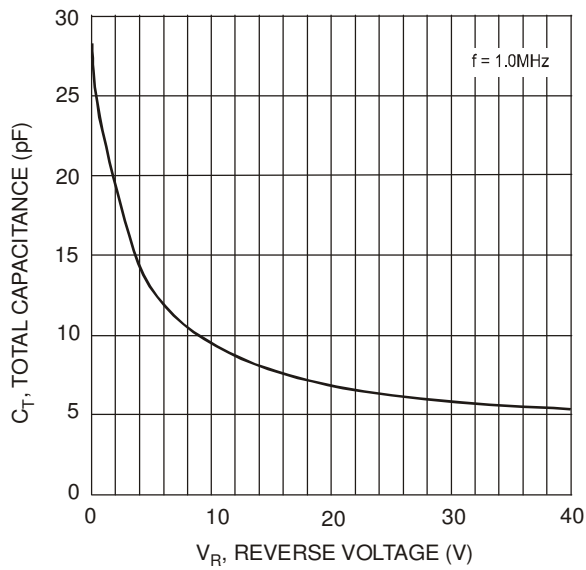
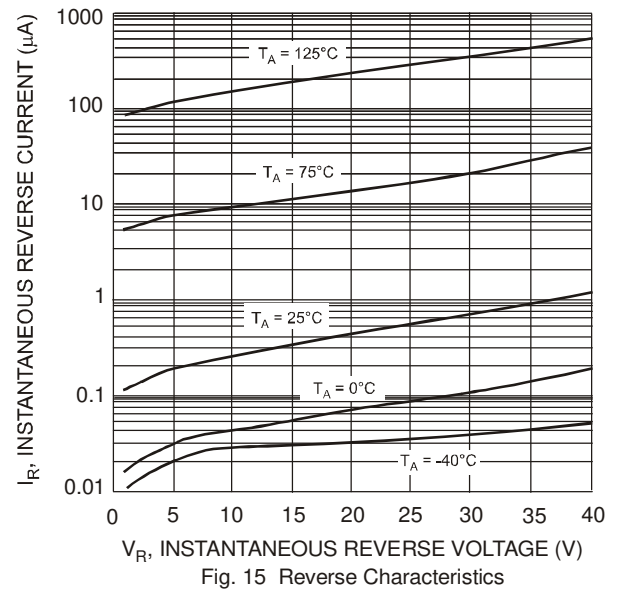
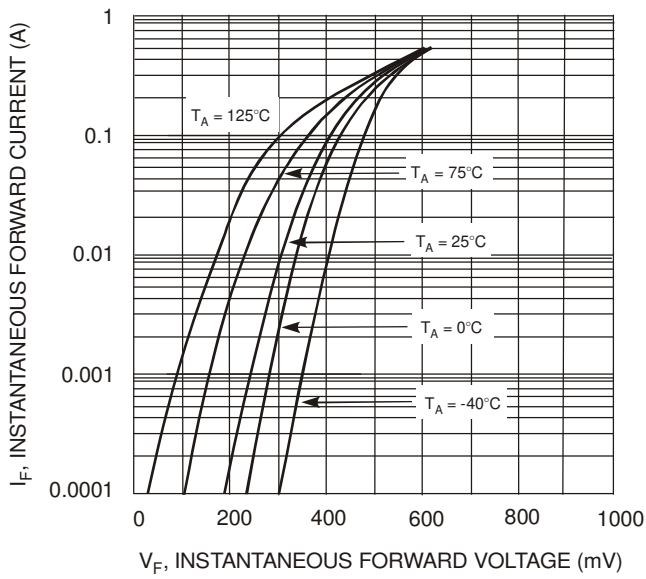

Fig. 13 Forward Transconductance vs. Drain Current ( $V_{DS} > I_D \cdot R_{DS(ON)}$ )

## Schottky Barrier Diode – D1 Characteristics



## Application Details

ESD Protected N-MOSFET (DMN601K) and Schottky Barrier Diode (SD103AWS) integrated as one in NMSD200B01 can be used as a discrete entity for general applications or part of circuits to function as a low side switch in a Synchronous Rectifier. The N-MOSFET is selected based on the input voltage range as the maximum duty cycles can be greater than 45%. Schottky diode is selected based on instantaneous  $V_f$  (less than 0.75 V) at maximum operation current. The Schottky diode dissipates very little power because it is on for only a small portion of the switching cycle. Normally it shows much lower leakage current and smaller on-resistance ( $R_{DS(ON)}$ ) even compared to its monolithic counterpart. This device is designed to improve efficiency and reliability of synchronous buck converters used in voltage regulator modules (VRM). The lower  $V_f$  of the Schottky diode leads to lower static loss. Every time the high side MOSFET is turned on in the buck converter, the low side Schottky diode is forced to recover the stored charge and there will be lower loss due to the lower Reverse Recovery charge of the Schottky diode.

It is designed to replace a discrete N-MOSFET and a Schottky diode in two separate packages into one small package as shown in Fig. 17. The Schottky diode parallel to the MOSFET body diode is faster and has lower voltage drop compared to the integrated body diode. Overall this device consumes less board space and also helps to minimize conduction or switching losses due to parasitic inductances (e.g. PCB traces) in power supply applications. (Please see Fig. 18 for one example of typical application circuit used in conjunction with DC-DC converter as a part of power management system and Fig. 19 for low side DC load control.)

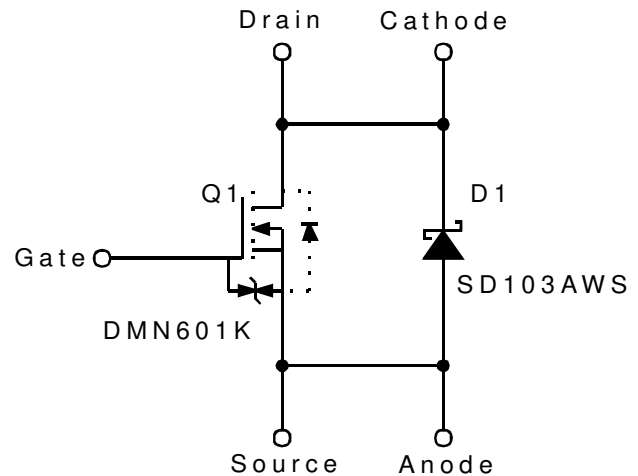

Fig. 17 Example Circuit Diagram

## Typical Application Circuits

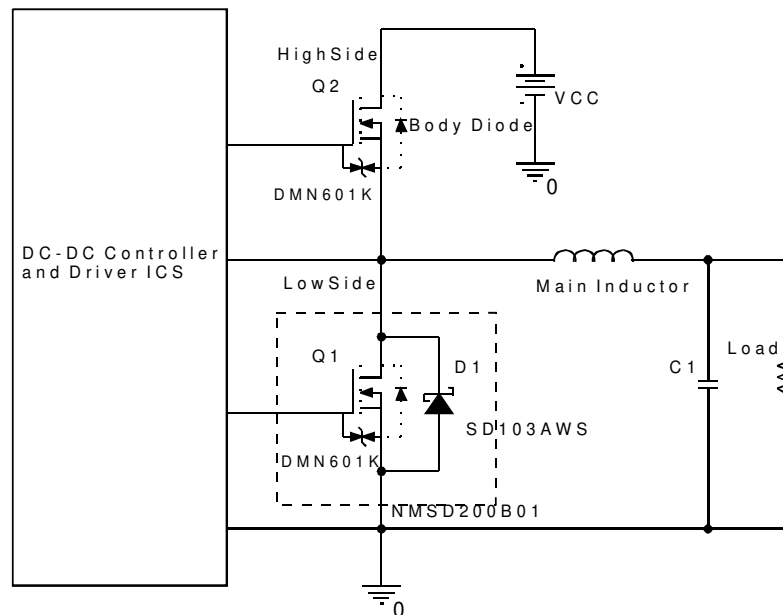
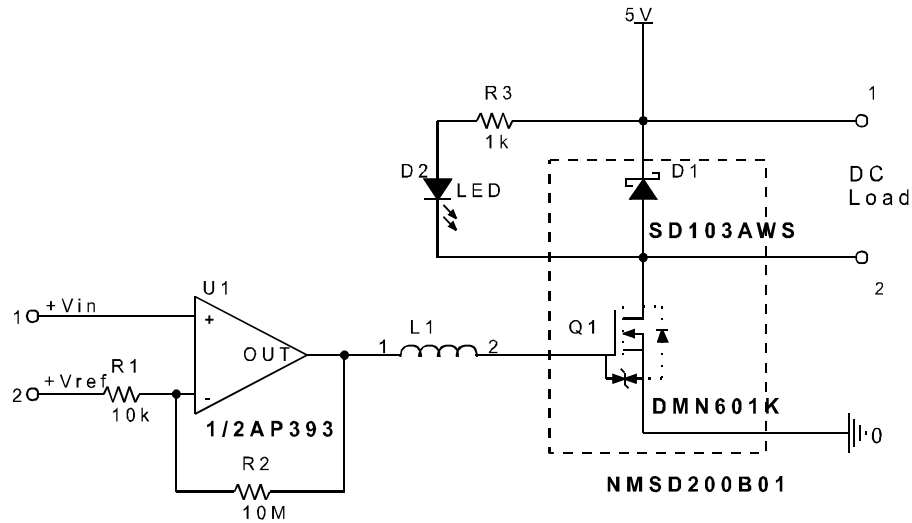

Fig. 18 Synchronous Buck Converter with Integrated Schottky Diode



(Comparator with Hysteresis)

Fig. 19 Low Side DC Load Control

## Ordering Information (Note 5)

Device	Marking Code	Packaging	Shipping
NMSD200B01-7	SR1	SOT-363	3000/Tape & Reel

Notes: 5. For Packaging Details, go to our website at <http://www.diodes.com/datasheets/ap02007.pdf>.

## Marking Information

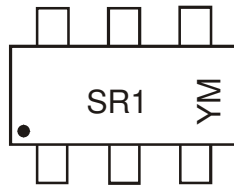

SR1 = Product Type Marking Code,  
 YM = Date Code Marking  
 Y = Year, e.g., T = 2006  
 M = Month, e.g., 9 = September

Fig. 20

### Date Code Key

Year	2006	2007	2008	2009	2010	2011	2012
Code	T	U	V	W	X	Y	Z

Month	Jan	Feb	Mar	Apr	May	Jun	Jul	Aug	Sep	Oct	Nov	Dec
Code	1	2	3	4	5	6	7	8	9	O	N	D



## Mechanical Details

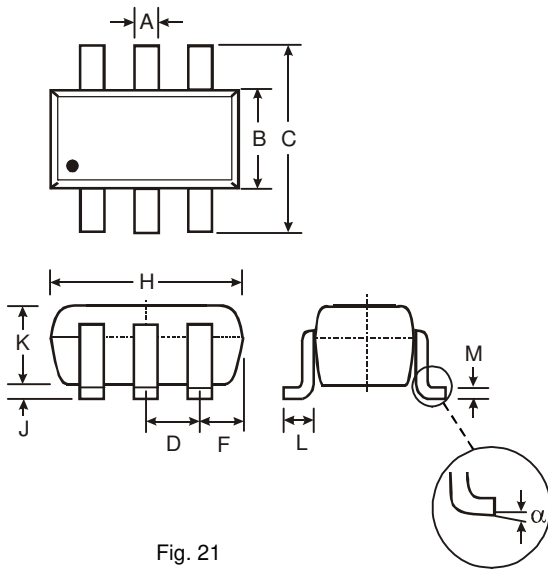

SOT-363		
Dim	Min	Max
A	0.10	0.30
B	1.15	1.35
C	2.00	2.20
D	0.65 Nominal	
F	0.30	0.40
H	1.80	2.20
J	—	0.10
K	0.90	1.00
L	0.25	0.40
M	0.10	0.25
$\alpha$	0°	8°
<b>All Dimensions in mm</b>		

## Suggested Pad Layout: (Based on IPC-SM-782)

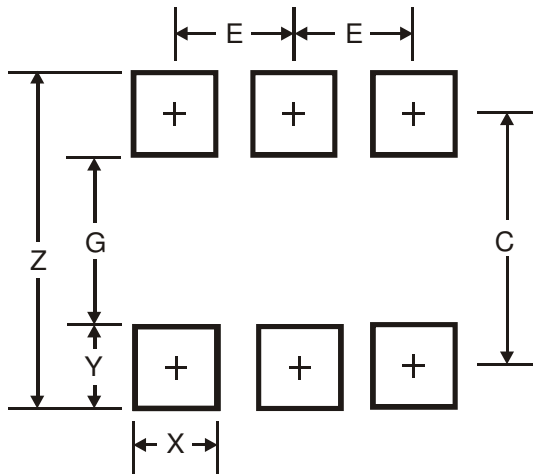

Figure 22 Dimensions	SOT-363*
Z	2.5
G	1.3
X	0.42
Y	0.6
C	1.9
E	0.65
*Typical dimensions in mm	

### IMPORTANT NOTICE

Diodes Incorporated and its subsidiaries reserve the right to make modifications, enhancements, improvements, corrections or other changes without further notice to any product herein. Diodes Incorporated does not assume any liability arising out of the application or use of any product described herein; neither does it convey any license under its patent rights, nor the rights of others. The user of products in such applications shall assume all risks of such use and will agree to hold Diodes Incorporated and all the companies whose products are represented on our website, harmless against all damages.

### LIFE SUPPORT

Diodes Incorporated products are not authorized for use as critical components in life support devices or systems without the expressed written approval of the President of Diodes Incorporated.