



Chipsmall Limited consists of a professional team with an average of over 10 year of expertise in the distribution of electronic components. Based in Hongkong, we have already established firm and mutual-benefit business relationships with customers from,Europe,America and south Asia,supplying obsolete and hard-to-find components to meet their specific needs.

With the principle of “Quality Parts,Customers Priority,Honest Operation,and Considerate Service”,our business mainly focus on the distribution of electronic components. Line cards we deal with include Microchip,ALPS,ROHM,Xilinx,Pulse,ON,Everlight and Freescale. Main products comprise IC,Modules,Potentiometer,IC Socket,Relay,Connector.Our parts cover such applications as commercial,industrial, and automotives areas.

We are looking forward to setting up business relationship with you and hope to provide you with the best service and solution. Let us make a better world for our industry!



Contact us

Tel: +86-755-8981 8866 Fax: +86-755-8427 6832

Email & Skype: info@chipsmall.com Web: www.chipsmall.com

Address: A1208, Overseas Decoration Building, #122 Zhenhua RD., Futian, Shenzhen, China



nRF24Z1 Evaluation board

nRF24Z1-EVB

1. General description

This document describes the **nRF24Z1-EVBOARD** and its use with the Nordic Semiconductor **nRF24Z1** Single Chip 2.4 GHz RF Audio streamer.

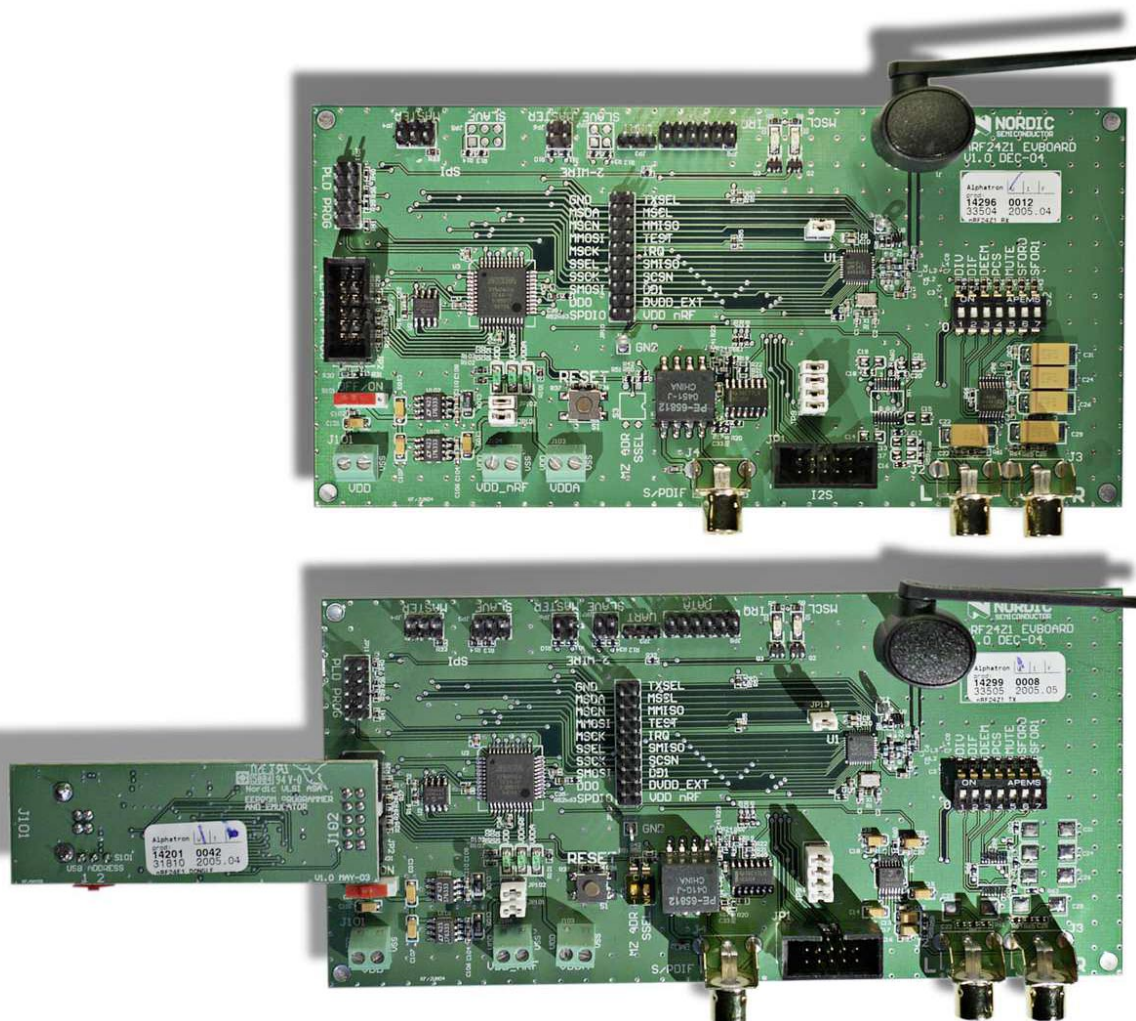

Figure 1: The **nRF24Z1-EVBOARD**

There are two versions of the nRF24Z1-EVBOARD. One is fitted with the nRF24Z1 in audio receiver (ARX) mode (Figure 1, top) the other with the nRF24Z1 set in audio transmitter (ATX) mode (Figure 1, bottom). The two boards are also populated differently in the audio front end section. The reason for the differences will be explained further in the following sections.



2. Introduction

The Evaluation Board for the **nRF24Z1** Single Chip 2.4 GHz RF audio streamer has been developed to enable customers to test functionality, run communication and verify the performance parameters of the device. This document describes the usage of the **nRF24Z1-EVBOARD**.

The **nRF24Z1-EVBOARD** is intended for evaluation and development purposes only. It is not intended for incorporation into an end product.

3. Getting started

The **nRF24Z1-EVBOARD** V1-0 is shipped with an EEPROM programmer and emulator (programming dongle). The nRF programming dongle enables you to download register settings and access the control link offered by **nRF24Z1**.

The following equipment is needed to work efficiently with the **nRF24Z1-EVBOARD**:

- PC with 1 free USB port
- Z1config PC software (supplied)
- 1 nRF EEPROM programmer and emulator (supplied)
- Two 2.0 V - 3.6V or one 4.6 – 12V DC voltage supply
- 1 male A/B USB cable (supplied)

To evaluate the performance of the device the following instrumentation should be available:

- Audio source, analog or digital. Analog audio input is AC coupled, with a maximum swing of 2.6Vpp (0.9Vrms). Minimum input resistance is 10kΩ. Digital audio input is via S/PDIF RCA phono connector (0.5Vpp,75Ω)
- Audio amplifier and loudspeakers. Analog audio out is 2.1Vpp (0.75Vrms) at a load of 5kΩ. Digital audio output is via S/PDIF RCA phono connector (0.5Vpp,75Ω)
- Oscilloscope
- 2.4 GHz Spectrum analyzer



4. Programming dongle description

The programming dongle is fitted 'on-top' (Figure 2) of the **nRF24Z1-EVBOARD** and controlled through PC software. The **Z1config** software is documented in Z1config user manual [1].

The dongle will mainly be fitted on the **nRF24Z1** audio transmitter (ATX) board. Through this interface the user also has full control of the audio receiver board through the control/data RF link offered by **nRF24Z1**. The dongle needs to be connected to the audio receiver board only if default configuration in the audio receiver EEPROM is to be changed.

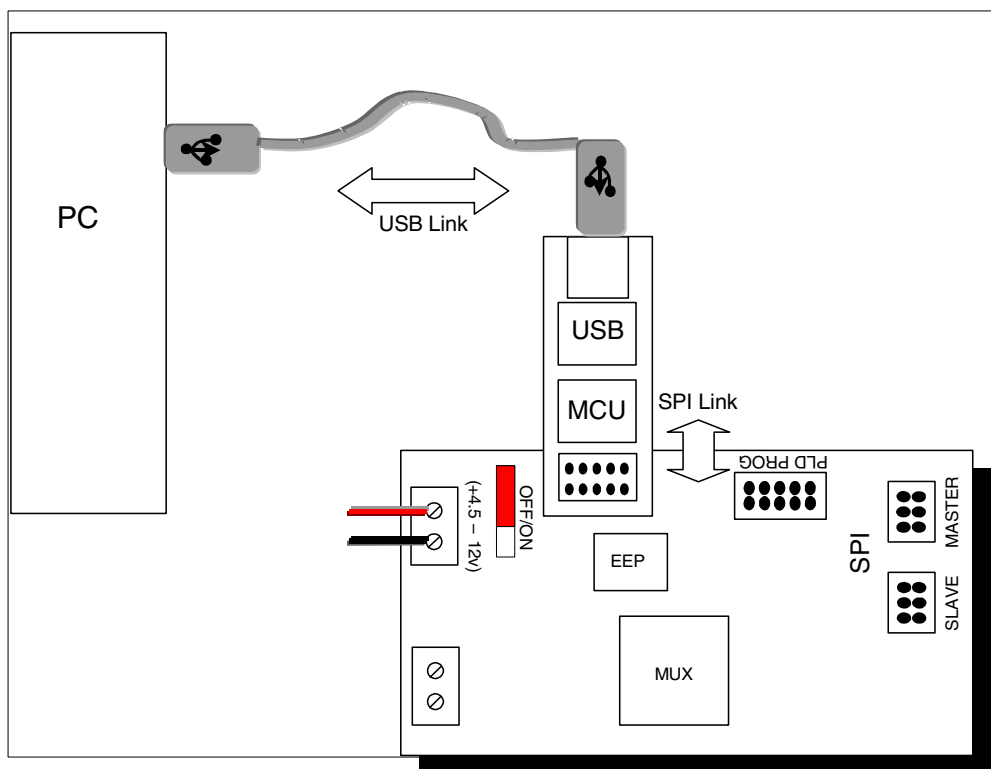

Figure 2: **nRF24Z1-EVBOARD** with programming dongle

4.1. Supply

Main power supply is fed to the nRF programming dongle through the USB interface (J101). Supply voltage to the **nRF24Z1-EVBOARD** interface stage runs through J102 from the **nRF24Z1-EVBOARD**. The programming dongle must hence be plugged in the EVBOARD connector JP2 in order to have proper signal levels on J102.



4.2. nRF24Z1-EVBOARD interface

The pin-out of the interface (J102) to the **nRF24Z1-EVBOARD** can be found under the **nRF24Z1-EVBOARD** description (EVBOARD connector JP2). The PC interface (J101) is a standard USB B-connector interface.

4.3. USB addressing (S101)

The dongle has an option to use 2 different USB addresses set by S101. This option is only needed if the same USB hub is to interface two dongles. The position of S101 is hence not important in the **nRF24Z1-EVKIT** unless you have two audio transmitter boards connected to the same PC (2 different EVKIT's) at the same time.



5. nRF24Z1-EVBOARD DESCRIPTION

Figure 3 shows the block diagram of the **nRF24Z1-EVBOARD**.

Further details can be found in appendix 1 (circuit diagram and PCB layout) and appendix 2 (component list).

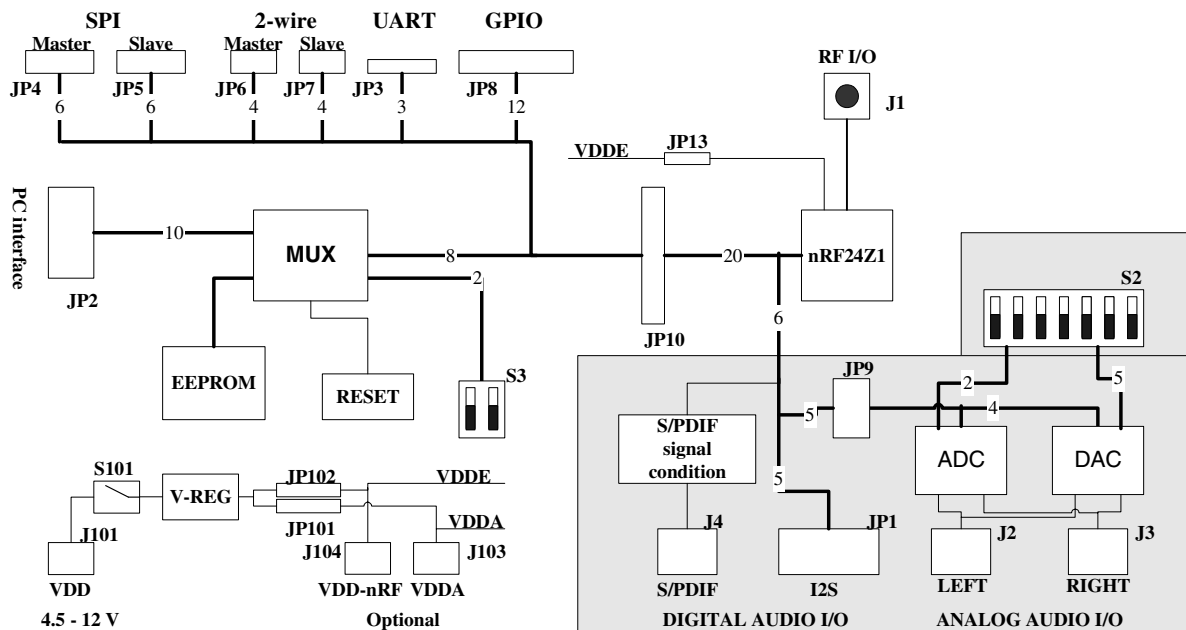

Figure 3: Block diagram of the **nRF24Z1-EVBOARD**

Due to the significant difference in functionality when the **nRF24Z1** is configured in audio transmitter mode (found at audio source side like the CD player) and in audio receiver mode (loud speaker side) the two EVBOARD's in the EVKIT are preset as audio transmitter and receiver. The audio section of the two versions of the EVBOARD are populated differently (S/PDIF and ADC/DAC section), but note that the section around **nRF24Z1** (device and external components) are identical on the two boards.

To enable convenient control of the **nRF24Z1-EVBOARD** from a computer, a MUX (Altera PLD) is put on the **nRF24Z1-EVBOARD** to ease PC interfacing with **nRF24Z1** and the on board EEPROM. The on board mux is hence only for EVBOARD versatility and not needed in a final design.

5.1. Supply (J101, J103, J104)

Power supply and ground is fed to the **nRF24Z1-EVBOARD** either through on-board voltage regulators (connector J101) or directly from external supplies (J103, J104). J101 is the primary VDD to be used with the **nRF24Z1-EVBOARD**.

If jumper JP101 (leave JP102) are removed, connector J104 supplies, supply to all circuitry except on the board ADC/DAC. J104 supplies VDDA, analog power for the on board ADC or



DAC. Supply on J104 is of course only needed if the analog audio front ends (ADC/DAC) are used.

S101 is the board ON/OFF switch for power fed through J101.

Note that VDD fed through J103 and J104 are fed directly to the circuitry ON/OFF must hence be managed from the power supplies.

ON is shown by lit green LED's. Note that if the supply voltage is ~2.0 V the light from the LED will be weak.

Please note the voltage limitations on the connectors. The on-board voltage regulator accepts an input voltage between 4.5 and 12 V, the regulated output voltage is 3.3V.

For device testing over the supply range (2.0 – 3.6V), J103 and J104 must be utilized. The voltage on these two connectors must always be equal, and there is NO protection on these VDD inputs. Pay special attention to the max value (3.6V) since this is also the absolute maximum rating of the **nRF24Z1**.

NOTE:

Voltages above 3.6V on J104 for extended time will destroy the **nRF24Z1**!

5.2. RESET

A **nRF24Z1** reset is forced either by pressing the RESET button (S1) on the PCB or manually through the PC software to the on board EEPROM via the USB dongle connected to JP2.

When the **nRF24Z1** is reset, configuration data is re-loaded from external memory and new RF link initialization is started.

In a final application external reset circuitry is not necessary, the reset circuitry on the EVBOARD is included to force re-load of configuration data and re-initialization of link during testing.

5.3. nRF24Z1 voltage and current measurements (JP13)

To enable accurate measurement of **nRF24Z1** current consumption a jumper (JP13) is put in the **nRF24Z1** supply line. This jumper is never to be removed, except when replaced by an ampere meter for measurements. The exact supply voltage to the **nRF24Z1** can also be measured on JP13.

5.4. I/O ports

For convenience, the digital I/O signals of the **nRF24Z1** are routed to separate connectors depending on functionality. Due to sharing of pins and different functionality in audio transmitter and audio receiver mode the same signals can be found in multiple connectors.

All signals can be accessed on JP10.



5.5. AUDIO I/O

The available audio interfaces of the **nRF24Z1** are available on separate connectors on the EVBOARD. The components in the **nRF24Z1-EVBOARD** audio section (grayed out in *Figure 3*) will vary depending on the mode (audio transmitter or receiver) the fitted **nRF24Z1** is set in.

NOTE:

Only one of the audio interfaces (I2S or S/PDIF) may be used at one time.

5.5.1. S/PDIF (J4)

The **nRF24Z1** SPDIO pin offers timing wise true S/PDIF input in audio transmitter (ATX) mode and similar output in audio receiver (ARX) mode. The SPDIO pin operates however with CMOS signal level so to get a true S/PDIF coax signal (0.5Vpp @ 75 Ω) a level shift and impedance match must be done. This is realized on board on the **nRF24Z1-EVBOARD** and connector J4 hence offers a true S/PDIF coax interface to external equipment.

5.5.2. I2S (JP1)

The **nRF24Z1** I2S interface can be accessed directly on JP1.

JP8 pin #	Signal name	Comment
1	MCLK	256x sample rate clock to ADC or DAC
2	GND	
3	CLK	I2S bit clock
4	GND	
5	WS	I2S word clock
6	GND	
7	DATA	I2S data
8	GND	
9	REQ	I2S data request
10	GND	

Table 1 **nRF24Z1-EVBOARD** JP1 I2S interface pin out

The **nRF24Z1-EVBOARD** connector JP1 offers a interface compatible with industry standard audio ADC and DAC's.

5.5.3. Analog line I/O (JP9, J2, J3)

By fitting jumpers on JP9 the I2S bus is also fed to an on board stereo ADC (ATX board) or a stereo DAC (ARX board). When using the on-board data converters left and right analog line I/O signals can be fed through J2 and J3 RCA connectors.



- Analog audio input is AC coupled, with a maximum swing of 2.6Vpp (0.9Vrms). Minimum input resistance is 10kΩ.
- Analog audio out is 2.1Vpp (0.75Vrms) at a load of 5kΩ.

5.5.4. DATA CONVERTER CONTROL (S2)

S2 switch	Signal name
DIV	ADC MCLK divide
DIF	ADC digital audio format
DEEM	DAC de-emphasize
PCS	DAC mode
MUTE	DAC mute
SFOR1	DAC digital audio format bit 1
SFOR0	DAC digital audio format bit 0

Table 2 nRF24Z1-EVBOARD JP1 I2S interface pin out

The audio transmitter board is equipped with a Crystal CS5333 AD converter [3] and the audio receiver board is equipped with a Philips UDA1334TS DA converter [4].

S2 provides access to various controls settings for the ADC and DAC. Please refer to the respective datasheets ([3], [4]).

Setting all S2 switches to ON, gives default function in ADC and DAC.

5.6. SERIAL CONTROL INTERFACES

5.6.1. Selecting control interface (S3)

The nRF24Z1 can be controlled as a slave on either SPI or 2-wire external serial interface. The SSEL pin selects which. In a final application this pin is clamped either high or low, but on the EVBOARD it is controlled by a switch found in S3. S3 also contains a switch setting one of two possible addresses nRF24Z1 answers to as 2-wire slave.

S3 switch name	Switch OFF	Switch ON	Functionality
SSEL	2-wire	SPI	Selects serial control interface
MZ ADR	Address bit a= 1	Address bit a = 0	Setting nRF24Z1 2-wire slave address. See nRF24Z1 product specification [2] for further details.

Table 3: nRF24Z1-EVBOARD, S3 functionality

5.6.2. SPI (JP4, JP5)

The SPI master and slave ports of nRF24Z1 are routed to JP4 and JP5.



In audio transmitter mode the SPI master is intended for connection of external memory (FLASH or EEPROM) holding configuration register data. This memory is connected through the MUX on the **nRF24Z1-EVBOARD**.

In audio receiver mode the SPI master port is controlled via the RF control channel offered between two **nRF24Z1** linked to each other. Please refer to the **nRF24Z1** product specification [2] for further details. To interface multiple slave units, GPIO pins (connector JP8) must be used as additional chip selects.

JP4 pin #	Signal name	Functionality
1	VDD	Power supply
2	MSCK	SPI master clock
3	MMOSI	SPI master out slave in
4	MCSN	SPI master chip select (active low)
5	MMISO	SPI Master in slave out
6	GND	Ground

Table 4: **nRF24Z1-EVBOARD**, JP4 SPI master pin out

The SPI slave port (JP5), enable external control of the **nRF24Z1** from a micro controller in audio transmitter mode.

In **nRF24Z1** audio receiver mode the SPI slave pins are used as GPIO (connector JP8), JP5 is hence not mounted on the **nRF24Z1** audio receiver mode board.

JP5 pin #	Signal name	Functionality
1	VDD	Power supply
2	SSCK	SPI slave clock
3	SMOSI	master out slave in
4	SCSN	chip select (active low)
5	SMISO	Master in slave out
6	GND	Ground

Table 5: **nRF24Z1-EVBOARD**, JP5 SPI slave pin out

5.6.3. 2-wire (JP6, JP7)

The 2-wire master and slave ports of **nRF24Z1** are routed to JP6 and JP7. The 2 wire interfaces of **nRF24Z1** are compatible with I2C.

In audio transmitter mode the 2-wire master is intended for connection of external memory (FLASH or EEPROM) holding configuration register data. This memory is connected on the SPI on the EVBOARD.

In audio receiver mode the 2-wire master port is controlled via the RF control channel offered between two **nRF24Z1** linked to each other. Please refer to the **nRF24Z1** product specification [2] for further details. Multiple 2-wire slaves can hence be connected to JP6



JP6 pin #	Signal name	Functionality
1	MSCL	2-wire master clock
2	VDD	Power supply
3	MSDA	2-wire master serial data
4	GND	Ground

Table 6: nRF24Z1-EVBOARD, JP6 2-wire master pin out

The 2-wire slave port (JP7), enable external control of the nRF24Z1 in audio transmitter (ATX) mode.

In nRF24Z1 audio receiver (ARX) mode these pins are used as GPIO (connector JP8), JP7 is hence not mounted on the nRF24Z1 ARX board.

JP7 pin #	Signal name	Functionality
1	SSCL	2-wire slave clock
2	VDD	Power supply
3	SSDA	2-wire slave serial data
4	GND	Ground

Table 7: nRF24Z1-EVBOARD, JP7 2-wire slave pin out

5.6.4. GPIO (JP8)

The nRF24Z1 offers a number of GPIO pins. The number and functionality of these pins differs between nRF24Z1 audio transmitter and audio receiver mode.

Audio transmitter:

2 inputs (3 if 2-wire serial interface is used) DD[0-2], the level on these inputs are re-created on DO[0-2] on a connected nRF24Z1 in ARX mode.

Audio receiver:

4 inputs DI[0-3] level on these inputs are mirrored in registers in a linked nRF24Z1 in ATX.

4 outputs DO[0-3]; DO[0-2] are reflecting the input level on DI[0-2] on a linked nRF24Z1 in audio transmitter mode. DO[3] can be controlled from a linked audio transmitter or set up as a PWM output.



Please refer to **nRF24Z1** product specification [2].

JP8 pin #	Signal name		Comment
	Audio transmitter	Audio receiver	
1	VDD	VDD	
2	TEST	TEST	Must be left open
3	DD0	DI0	
4	DD1	DI1	
5	DI2 (SMOSI)	DI2	SMOSI if SPI control interface is selected
6	SCSN/SADR	DI3	
7	SSCK/SSCL	DO0	
8	SMISO/SSDA	DO1	
9	SSEL	DO2	
10	IRQ	DO3/PWM	
11	TEST	TEST	Must be left open
12	GND	GND	

Table 8: **nRF24Z1-EVBOARD**, JP8 GPIO pin out

As can be seen in *Table 8*, pin 5-10 in JP8 is GPIO in audio receiver mode but carries the serial slave interface when in audio transmitter. The serial slave interfaces are also available at connector JP5 and JP7.

5.6.5. PC interface (JP2)

JP2 enables **nRF24Z1-EVBOARD** control from PC software. JP2 only interacts with the MUX, and only the USB dongle supplied with the EVKIT must be plugged in here.

The pin out of JP2 is listed in table *Table 9*.

Pin number	Pin name	Comment
1	VDD	nRF24Z1-EVBOARD supply voltage
2	VER	nRF24Z1-EVBOARD rev. code
3	DG_CSCNTRL	
4	DG_CSN	
5	DG_SO	
6	DG_WPN	
7	DG_SI	
8	DG_SCK	
9	RESET	
10	GND	

Table 9 **nRF24Z1-EVBOARD** J7 pin out

Note:

For the USB dongle / evboard to function properly, **nRF24Z1-EVBOARD** supply voltage must be turned on.



5.6.6. RF I/O (J1)

For convenient connection of the differential antenna output/input pins to a single ended antenna or 50Ω test equipment, a differential to single ended matching network is included. This network matches the 50Ω single end antenna or 50Ω test equipment impedance at the SMA connector J1 to the recommended differential load impedance at the nRF24Z1's RF I/O stage (pins ANT1 & ANT2). The employed matching network introduces an insertion loss of approximately 1dB at 2.4 GHz..

6. REFERENCES

- [1] Z1config user manual, Nordic Semiconductor
- [2] nRF24Z1-prelim-rev1_2.doc, Nordic Semiconductor
- [3] Cirrus Logic: http://www.cirrus.com/en/products/pro/areas/mixedsig_av.html
- [4] Philips Semiconductor:
http://www.semiconductors.philips.com/pip/UDA1334TS_N1.html

Please see <http://www.nordicsemi.no> for latest version of documents from Nordic Semiconductor



APPENDIX 1: CIRCUIT DIAGRAM AND PCB LAYOUT

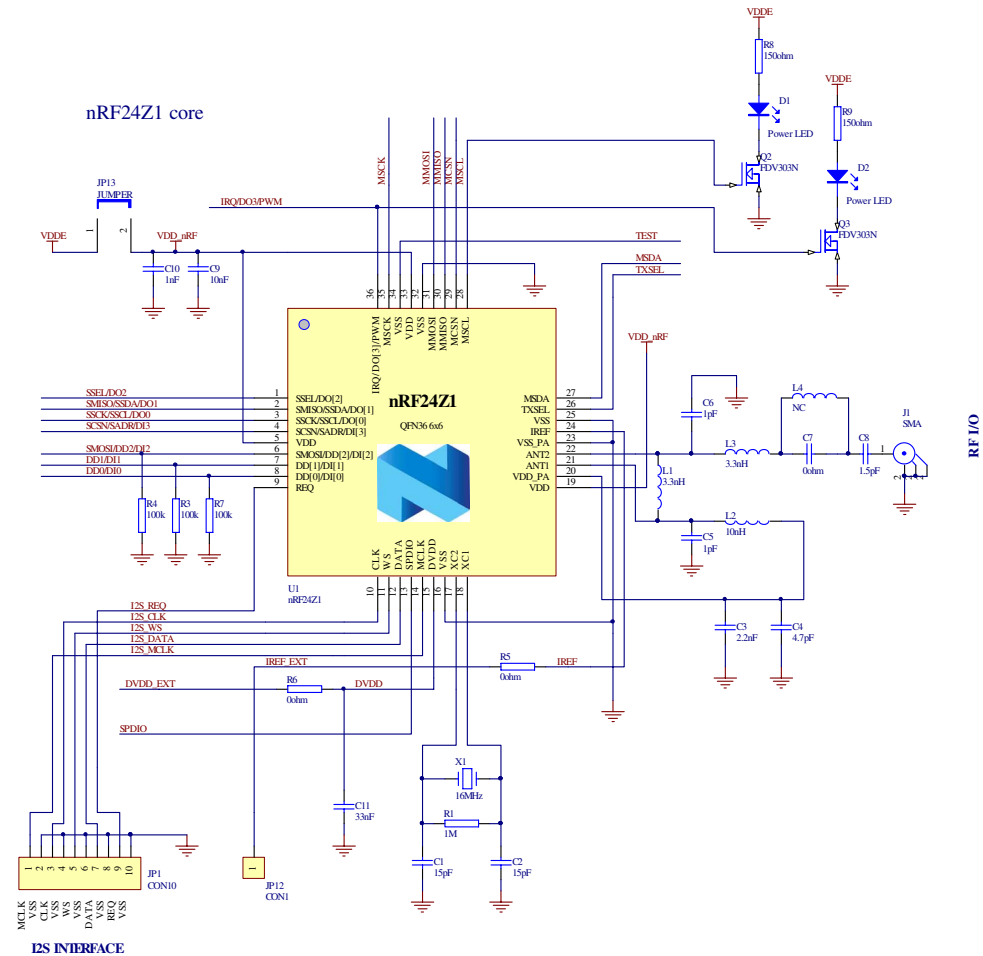

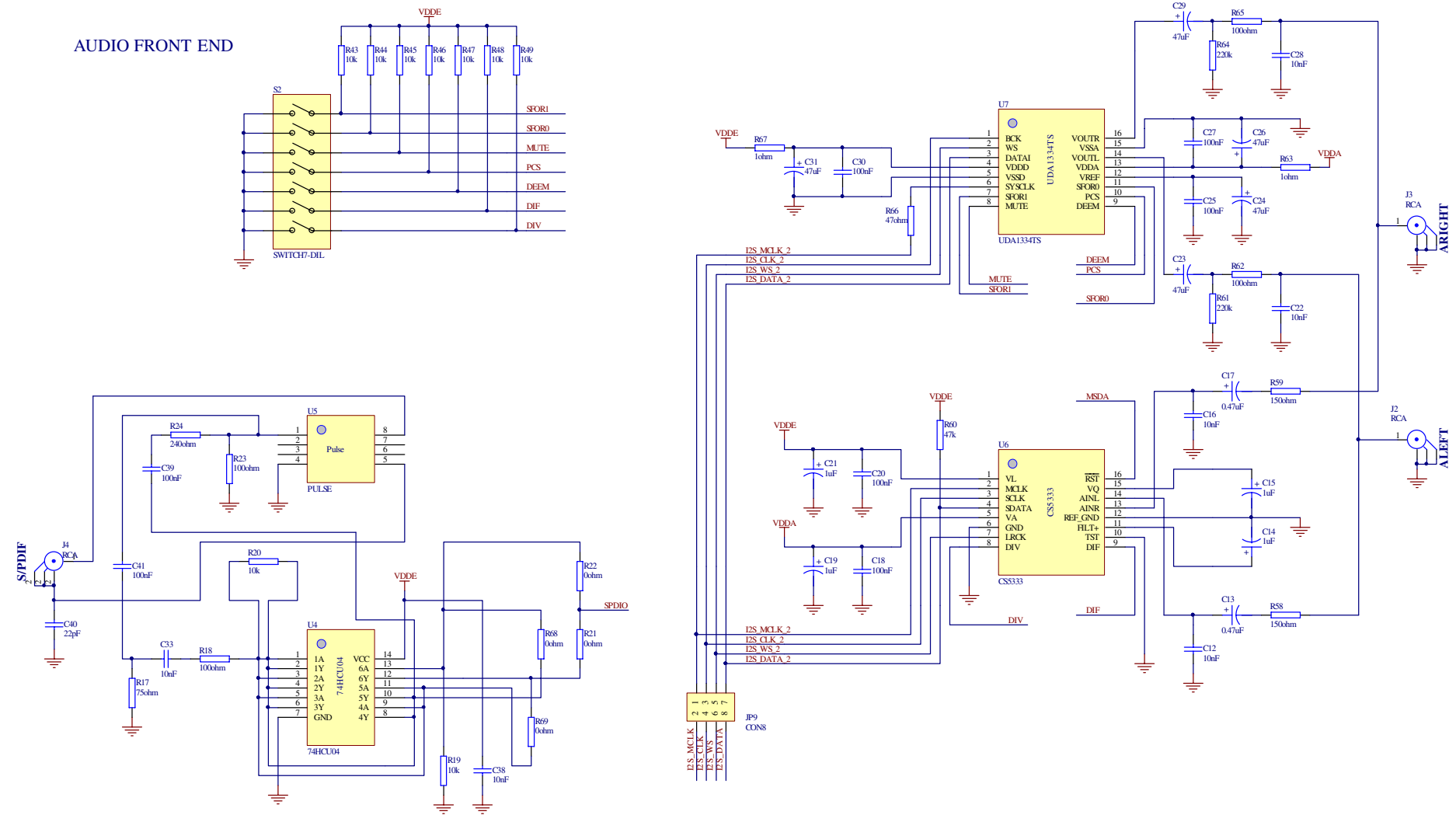

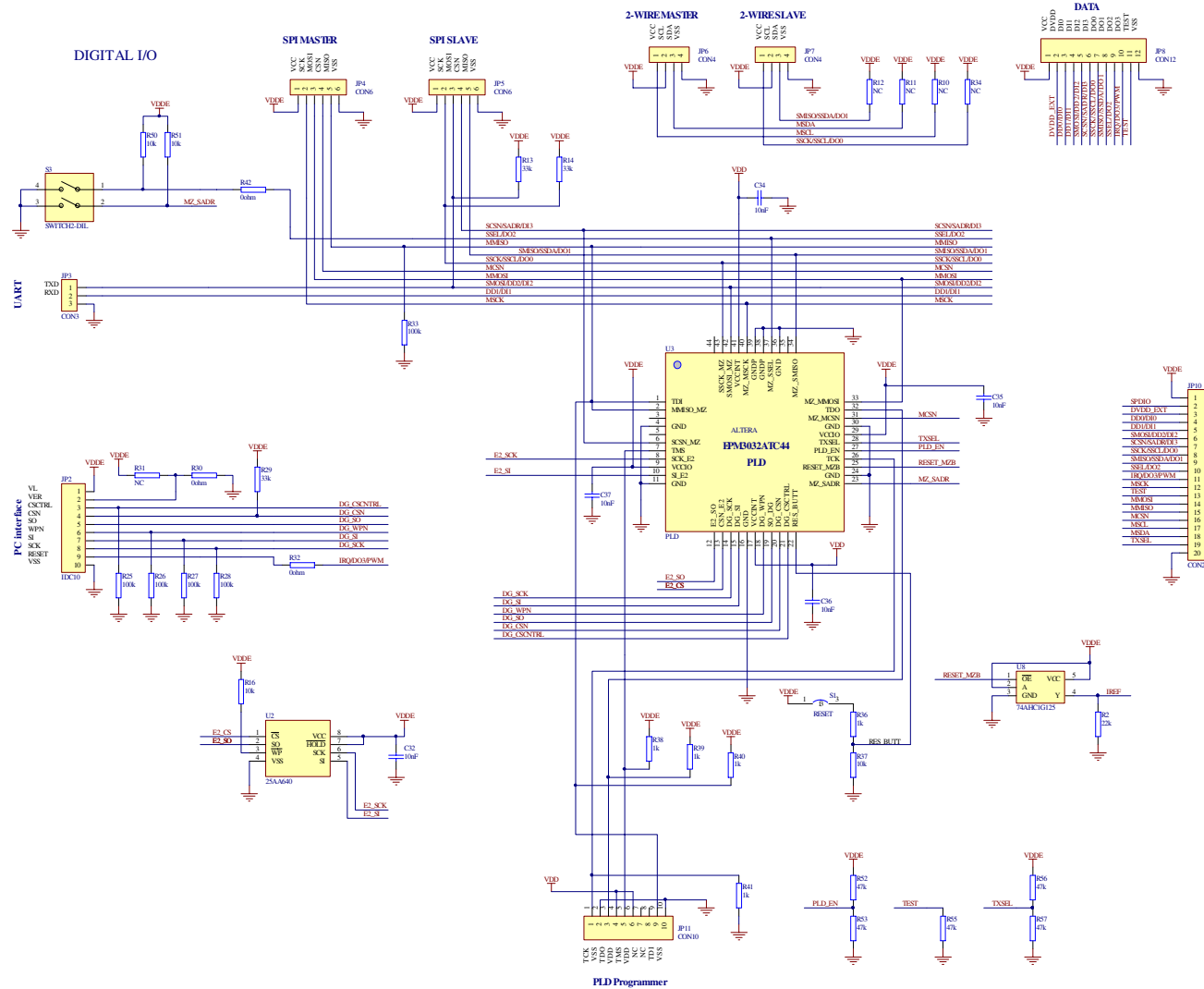

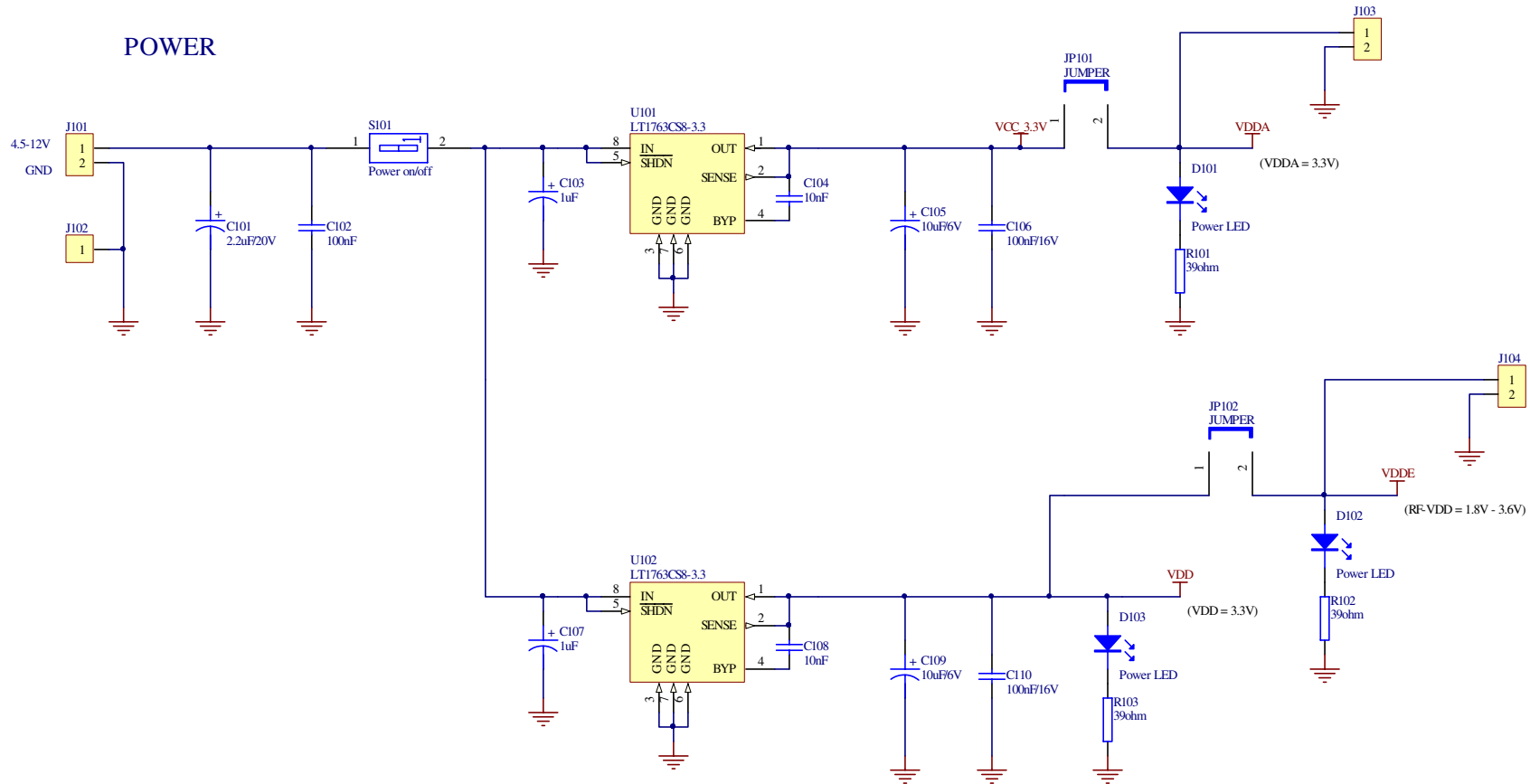

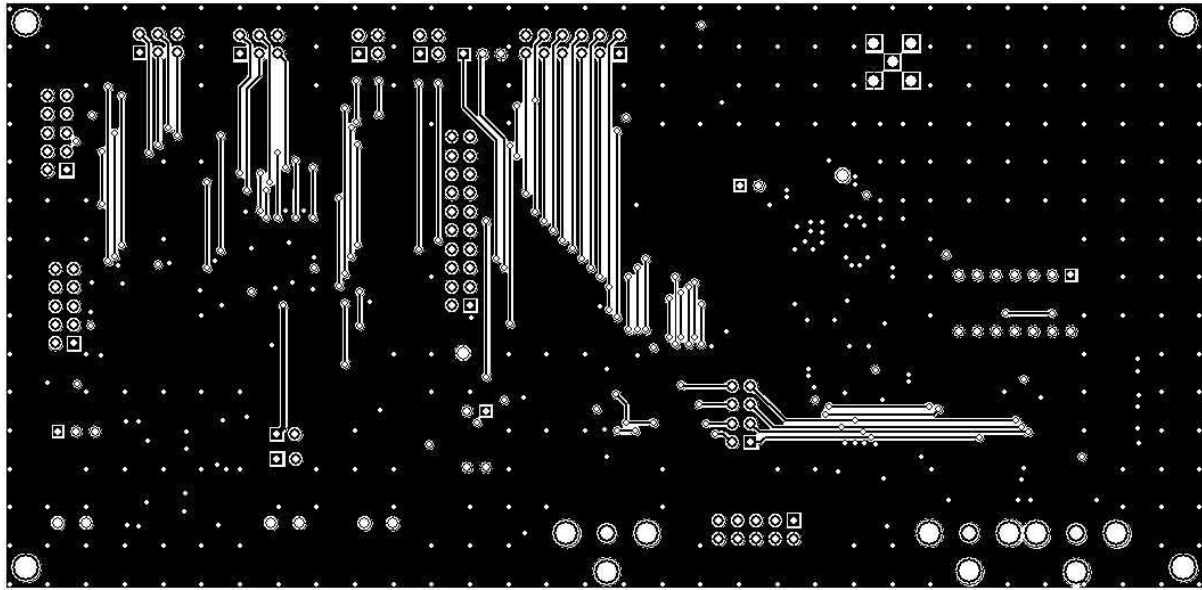

Bottom signal layer

Figure 4 nRF24Z1-EVBOARD Circuit diagram and PCB layout

There are no components in bottom layer. The board is 4 layers with a ground plane in inner-layer 1 and a split power plane (VDD and VDDA) in inner-layer 2.

**APPENDIX 2: COMPONENT LIST**

Designator	Description	Part Type	Footprint	Comment
C1	Capacitor Ceramic	15pF	0603	
C2	Capacitor Ceramic	15pF	0603	
C3	Capacitor Ceramic	2.2nF	0603	
C4	Capacitor Ceramic	4.7pF	0603	
C5	Capacitor Ceramic	1.0pF	0603	
C6	Capacitor Ceramic	1.0pF	0603	
C7	Capacitor Ceramic	2.2pF	0603	replaced by a 0 ohm resistor
C8	Capacitor Ceramic	1.5pF	0603	
C9	Capacitor Ceramic	10nF	0603	
C10	Capacitor Ceramic	1nF	0603	
C11	Capacitor Ceramic	33nF	0603	
C12	Capacitor Ceramic	10nF	0603	only for TX, not mounted on RX
C13	Capacitor Tantalum	0.47uF	3216	only for TX, not mounted on RX
C14	Capacitor Tantalum	1uF	3216	only for TX, not mounted on RX
C15	Capacitor Tantalum	1uF	3216	only for TX, not mounted on RX
C16	Capacitor Ceramic	10nF	0603	only for TX, not mounted on RX
C17	Capacitor Tantalum	0.47uF	3216	only for TX, not mounted on RX
C18	Capacitor Ceramic	100nF	0603	only for TX, not mounted on RX
C19	Capacitor Tantalum	1uF	3216	only for TX, not mounted on RX
C20	Capacitor Ceramic	100nF	0603	only for TX, not mounted on RX
C21	Capacitor Tantalum	1uF	3216	only for TX, not mounted on RX
C22	Capacitor Ceramic	10nF	0603	only for RX, not mounted on TX
C23	Capacitor Tantalum	47uF	7343	only for RX, not mounted on TX
C24	Capacitor Tantalum	47uF	7343	only for RX, not mounted on TX
C25	Capacitor Ceramic	100nF	0603	only for RX, not mounted on TX
C26	Capacitor Tantalum	47uF	7343	only for RX, not mounted on TX
C27	Capacitor Ceramic	100nF	0603	only for RX, not mounted on TX
C28	Capacitor Ceramic	10nF	0603	only for RX, not mounted on TX



C29	Capacitor Tantalum	47uF	7343	only for RX, not mounted on TX
C30	Capacitor Ceramic	100nF	0603	only for RX, not mounted on TX
C31	Capacitor Tantalum	47uF	7343	only for RX, not mounted on TX
C32	Capacitor Ceramic	10nF	0603	
C33	Capacitor Ceramic	10nF	0603	only for TX, not mounted on RX
C34	Capacitor Ceramic	10nF	0603	
C35	Capacitor Ceramic	10nF	0603	
C36	Capacitor Ceramic	10nF	0603	
C37	Capacitor Ceramic	10nF	0603	
C38	Capacitor Ceramic	10nF	0603	
C39	Capacitor Ceramic	100nF	0603	only for RX, not mounted on TX
C40	Capacitor Ceramic	22pF	0603	
C41	Capacitor Ceramic	100nF	0603	only for TX, not mounted on RX
C101	Capacitor Tantalum	2.2uF	3216	
C102	Capacitor Ceramic	100nF	0603	
C103	Capacitor Tantalum	1uF	3216	
C104	Capacitor Ceramic	10nF	0603	
C105	Capacitor Tantalum	10uF	3216	
C106	Capacitor Ceramic	100nF	0603	
C107	Capacitor Tantalum	1uF	3216	
C108	Capacitor Ceramic	10nF	0603	
C109	Capacitor Tantalum	10uF	3216	
C110	Capacitor Ceramic	100nF	0603	
D1	LED, yellow	If,max = 30mA	LED_1206	
D2	LED, yellow	If,max = 30mA	LED_1206	
D101	LED, green	If,max = 30mA	LED_1206	
D102	LED, green	If,max = 30mA	LED_1206	
D103	LED, green	If,max = 30mA	LED_1206	
J1	RF I/O	SMA connector	through-hole	



J2	Left Channel Analog Connector	RCA connector	through-hole	
J3	Right Channel Analog Connector	RCA connector	through-hole	
J4	S/PDIF Connector	RCA connector	through-hole	
JP1	I2S Interface Connector	Flat Cable Connector, 10 pin	through-hole	
JP2	Programming Interface Connector	Flat Cable Connector, 10 pin	through-hole	
JP3	RS232 Interface Connector	Pin-header, 2.54 pitch, 3x1 pin	through-hole	
JP4	SPI Interface Master Connector	Pin-header, 2.54 pitch, 2x3 pin	through-hole	
JP5	SPI Interface Slave Connector	Pin-header, 2.54 pitch, 2x3 pin	through-hole	only for TX, not mounted on RX
JP6	2-Wire Interface Master Connector	Pin-header, 2.54 pitch, 2x2 pin	through-hole	
JP7	2-Wire Interface Slave Connector	Pin-header, 2.54 pitch, 2x2 pin	through-hole	only for TX, not mounted on RX
JP8	Measurement Connector	Pin-header, 2.54 pitch, 2x6 pin	through-hole	
JP9	Audio Codec I2S Connector	Pin-header, 2.54 pitch, 2x4 pin	through-hole	
JP10	Measurement Connector	Pin-header, 2.54 pitch, 2x5 pin	through-hole	
JP11	PLD Programming Interface Connector	Pin-header, 2.54 pitch, 2x5 pin	through-hole	
JP12	Testpoint	Soldering tag	through-hole	
JP13	VDD_nRF	Pin-header, 2.54 pitch, 2x1 pin	through-hole	
J101	Power Connector	2 pin	through-hole	
J102	Testpoint	Soldering tag	through-hole	
J103	Power Connector	2 pin	through-hole	
J104	Power Connector	2 pin	through-hole	
JP101	VDDA	Pin-header, 2.54 pitch, 2x1 pin	through-hole	
JP102	VDDE	Pin-header, 2.54 pitch, 2x1 pin	through-hole	
L1	Chip Inductor	3.3nH, TOKO, LL1608-FS3N3S	0603	
L2	Chip Inductor	10nH, TOKO, LL1608-FS10NJ	0603	
L3	Chip Inductor	3.3nH, TOKO, LL1608-FS3N3S	0603	
L4	Chip Inductor		0603	NC
Q2	DMOS N-channel	FDV303N	SOT-23D	
Q3	DMOS N-channel	FDV303N	SOT-23D	



R1	Resistor	1M	0603	
R2	Resistor	22k	0603	
R3	Resistor	1k	0603	
R4	Resistor	NC	0603	NC
R5	Resistor	NC	0603	NC
R6	Resistor	NC	0603	NC
R7	Resistor	100k	0603	
R8	Resistor	150ohm	0603	
R9	Resistor	150ohm	0603	
R10	Resistor	NC	0603	NC
R11	Resistor	NC	0603	NC
R12	Resistor	NC	0603	NC
R13	Resistor	33k	0603	only for TX, not mounted on RX
R14	Resistor	33k	0603	only for TX, not mounted on RX
R16	Resistor	10k	0603	
R17	Resistor	75ohm	0603	only for TX, not mounted on RX
R18	Resistor	100 ohm	0603	only for TX, not mounted on RX
R19	Resistor	10k	0603	only for TX, not mounted on RX
R20	Resistor	10k	0603	only for TX, not mounted on RX
R21	Resistor	0ohm	0603	only for TX, not mounted on RX
R22	Resistor	0ohm	0603	only for RX, not mounted on TX
R23	Resistor	100ohm	0603	only for RX, not mounted on TX
R24	Resistor	240ohm	0603	only for RX, not mounted on TX
R25	Resistor	100k	0603	
R26	Resistor	100k	0603	
R27	Resistor	100k	0603	
R28	Resistor	100k	0603	
R29	Resistor	33k	0603	
R30	Resistor	0ohm	0603	
R31	Resistor	NC	0603	NC



R32	Resistor	NC	0603	NC
R33	Resistor	100k	0603	
R34	Resistor	NC	0603	NC
R36	Resistor	1k	0603	
R37	Resistor	10k	0603	
R38	Resistor	1k	0603	
R39	Resistor	1k	0603	
R40	Resistor	1k	0603	
R41	Resistor	1k	0603	
R42	Resistor	0ohm	0603	only for TX, not mounted on RX
R43	Resistor	10k	0603	
R44	Resistor	10k	0603	
R45	Resistor	10k	0603	
R46	Resistor	10k	0603	
R47	Resistor	10k	0603	
R48	Resistor	10k	0603	
R49	Resistor	10k	0603	
R50	Resistor	10k	0603	only for TX, not mounted on RX
R51	Resistor	10k	0603	only for TX, not mounted on RX
R52	Resistor	47k	0603	
R53	Resistor	NC	0603	NC
R55	Resistor	47k	0603	
R56	Resistor	47k	0603	only for TX, not mounted on RX
R57	Resistor	47k	0603	only for RX, not mounted on TX
R58	Resistor	150ohm	0603	only for TX, not mounted on RX
R59	Resistor	150ohm	0603	only for TX, not mounted on RX
R60	Resistor	47k	0603	only for TX, not mounted on RX
R61	Resistor	220k	0603	only for RX, not mounted on TX
R62	Resistor	100ohm	0603	only for RX, not mounted on TX
R63	Resistor	1ohm	0603	only for RX, not mounted on TX
R64	Resistor	220k	0603	only for RX, not mounted on TX



R65	Resistor	100ohm	0603	only for RX, not mounted on TX
R66	Resistor	47ohm	0603	only for RX, not mounted on TX
R67	Resistor	1ohm	0603	only for RX, not mounted on TX
R68	Resistor	0ohm	0603	only for TX, not mounted on RX
R69	Resistor	0ohm	0603	only for RX, not mounted on TX
R101	Resistor	39ohm	0603	
R102	Resistor	39ohm	0603	
R103	Resistor	39ohm	0603	
S1	RESET, Push button	Alps, SKHUAD		
S2	DIL switch	NDIR-07ST	through-hole	
S3	DIL switch	NDIR-02ST	through-hole	only for TX, not mounted on RX
S101	Power, Slide switch	Eao, 1K2	through-hole	
U1		nRF24Z1	QFN 36L	
U2	EEPROM	Microchip, 25AA640	SO-8	
U3	Programmable Logic Device	Altera, EPM3032ATC44-4/7/10	44-pin TQFP	
U4	Hex Inverter	74HCU04	SO14	
U5	1:1 Pulse Transformer	PE-65812		
U6	Cirrus Logic, Stereo A/D Converter	CS5333	16L TSSOP	only for TX, not mounted on RX
U7	Philips, Stereo D/A Converter	UDA1334TS	SSOP16	only for RX, not mounted on TX
U8	Philips, 3-state bus buffer/line driver	7HAHC1G125	SOT353-5	
U101	Linear Voltage Regulator	LT1763CS8-3.3	SO-8	
U102	Linear Voltage Regulator	LT1763CS8-3.3	SO-8	
X1	Crystal	16MHz	OFM	

Table 10: nRF24Z1-EVBOARD component list

The nRF24Z1-EVBOARD is manufactured on a 1.6mm thick, 4 layer, FR4 substrate.



1. LIABILITY DISCLAIMER

Nordic Semiconductor ASA reserves the right to make changes without further notice to the product to improve reliability, function or design. Nordic Semiconductor does not assume any liability arising out of the application or use of any product or circuits described herein.

LIFE SUPPORT APPLICATIONS

These products are not designed for use in life support appliances, devices, or systems where malfunction of these products can reasonably be expected to result in personal injury. Nordic Semiconductor ASA customers using or selling these products for use in such applications do so at their own risk and agree to fully indemnify Nordic Semiconductor ASA for any damages resulting from such improper use or sale.

User manual, Revision: 1.3, Date: 2005-05-02.

User manual Note order code: nRF24Z1-EVB 20050502

All rights reserved ®. Reproduction in whole or in part is prohibited without the prior written permission of the copyright holder.