



Chipsmall Limited consists of a professional team with an average of over 10 year of expertise in the distribution of electronic components. Based in Hongkong, we have already established firm and mutual-benefit business relationships with customers from,Europe,America and south Asia,supplying obsolete and hard-to-find components to meet their specific needs.

With the principle of "Quality Parts,Customers Priority,Honest Operation,and Considerate Service",our business mainly focus on the distribution of electronic components. Line cards we deal with include Microchip,ALPS,ROHM,Xilinx,Pulse,ON,Everlight and Freescale. Main products comprise IC,Modules,Potentiometer,IC Socket,Relay,Connector.Our parts cover such applications as commercial,industrial, and automotives areas.

We are looking forward to setting up business relationship with you and hope to provide you with the best service and solution. Let us make a better world for our industry!



Contact us

Tel: +86-755-8981 8866 Fax: +86-755-8427 6832

Email & Skype: info@chipsmall.com Web: www.chipsmall.com

Address: A1208, Overseas Decoration Building, #122 Zhenhua RD., Futian, Shenzhen, China





NT-Series Operator Interface Terminals



Software

High Function Touch Screens
NT21/31/631

Basic Function Touch Screens
NT20S/600S

Large Function Key Unit
NT11S

Small Function Key Units
NT2S

Technical Highlights

... PROCESS DISPLAY PROBLEMS?

solve it™ here!

Take the Right Action at the Right Time

The increased speed demanded by growing productivity goals makes your operators' decision skills more critical than ever. They need clearly displayed information at real-time speed to respond effectively. Omron's operator interface terminals let you control and access critical information from a single point to help operators stay on top of your process. The graphic and message development software to support the terminals has a short learning curve so your application will be ready sooner for commissioning. Omron's NT-series operator interface terminals offer the right solution at the right time.

Choose an Experienced Partner

With over 65 years of experience manufacturing industrial controls, Omron brings the know-how and reliable products to help you solve tough production problems. Whether you choose to use Omron operator interface terminals with Omron programmable controllers or with those from other manufacturers, we can work with you to develop a flexible and cost-effective system that responds to your current and future needs. Expertise in packaging, material handling, electronics and small parts assembly, food and beverage, semiconductor manufacturing and other specialized applications makes Omron an experienced partner well-qualified to help with your project.

World Recognized Versatility and Support

Omron products represent the best value in capabilities for the investment. Our product designs meet international safety ratings (UL, CE) to speed certification of machinery for commissioning or export. Easy-to-use, multilingual display capabilities and translation utility in the development software give you advantages in providing information to operators in their local language without having to modify the graphics to accommodate each language. With global sales and support that provide spare parts and service locally, you can confidently design in Omron operator interface terminals for machinery going all over the globe.



Strong Products and Intuitive Software Combine for Great Performance

- Wide selection of touch screens and function key models include everything from simple touch switches, lamps, bar graphs and text to models that handle animation, recipes, trend graphs and background math calculation.
- Easy-to-use graphical development software NT-Series Support Tool provides a Windows®-based environment with menu driven, drag-and-drop programming. Manage project screens and tables from a convenient tree menu. Many features shorten debugging time to shorten startup.
- Get more live area and less bezel with Omron's NEMA 4 touch screens for efficient use of panel real estate. Shallow mounting depth of less than 2 inches allows thinner panel designs.
- Rigorous testing every step of the way ensures smooth installation and commissioning. Firmware programming, communications drivers and hardware are tested individually and in combination for flawless performance. Each terminal undergoes thermal, noise, vibration and shock testing to withstand extreme conditions defined in our specifications.
- Versatile communications, faster updates provide the flexibility you need to get information to operators. Omron's NT Link protocol provides high-speed serial transmission (up to 115k baud) for one or multiple terminals and one PLC. Create screen programs that do not require modification across multiple PLC platforms using the DeviceNet communications capability. Memory Link protocol allows the terminal to communicate with a serial port on a PC or custom board.



Contents

Selection Guide	4 - 5
Warranty	6
Programming Software	7 - 11
Operator Interface Terminals	13
High Function Touch Screens NT21 / NT31 / NT631	14 - 21
Basic Function Touch Screens NT20S / NT600S	22 - 25
Large Function Key Unit NT11S	26 - 29
Small Function Key Units NT2S	30 - 33
Technical Highlights	35
Cable Solutions for Omron PLCs	36 - 39
Cable Solutions for Multi-Vendor PLCs	40 - 44
NT Link Connection	45
DeviceNet Communications	46 - 48
Memory Link	49 - 51
Solve It Center - Omron Products	52 - 53
Worldwide Sales Offices	54 - 55

Software

NT21/31/631

NT20S/600S

NT11S

NT2S

Technical
Highlights

Selection Guide

Software

NT21/31/631

NT20S/600S

NT11S

NT2S

Technical Highlights



NT631

NT31

NT21

Display		NT631	NT31	NT21
Type		STN, TFT, Electroluminescent	STN	STN
Size		10.4 or 11.3 inch diagonal	5.7 inch	5.2 inch
Resolution		640 x 480 pixels	320 x 240 pixels	260 x 140 pixels
Interface		Touch screen	Touch screen	Touch screen
Memory				
Type		1 Mb, Flash EPROM	1 Mb, Flash EPROM	512 Kb, Flash EPROM
Max. screen storage		3999	3999	3999
Features				
Freeform drawing	Yes	Yes	Yes	
Bitmap	Yes	Yes	Yes	
Tiling (color or texture fill)	Yes	Yes	Yes	
Bar graph	Yes	Yes	Yes	
Needle gauge	Yes	Yes	Yes	
Line trending	Yes	Yes	Yes	
Thumbwheel	Yes	Yes	Yes	
Bit controlled input lockout	Yes	Yes	Yes	
Recipe table	Yes	Yes	Yes	
Math function	Yes	Yes	Yes	
Programming console	Yes	Yes	Yes	
Pop-up windows	Yes	Yes	Yes	
Device monitor function	Yes	Yes	No	
Real time clock	Yes	Yes	No	
Printer port	Yes	Yes	No	
Memory unit support	Yes	Yes	Yes	
Communications			Yes	
Host link	Yes	Yes	Yes	Yes
NT link	Yes	Yes	Yes	Yes
High-speed NT link	Yes	Yes	Yes	Yes
Allen-Bradley	Yes	Yes	Yes	No
GE Fanuc	Yes	Yes	Yes	No
Mitsubishi	Yes	Yes	Yes	No
Siemens	Yes	Yes	Yes	No
Modicon	Yes	Yes	Yes	No
Memory Link	Yes	Yes	Yes	Yes
General specifications				
Overall dimensions mm (in)		315 W x 250 H x 54 D (12.40 x 9.84 x 2.13)	196 W x 142 H x 54 D (7.72 x 5.59 x 2.13)	190 W x 110 H x 53.5 D (7.48 x 4.33 x 2.11)
Panel cutout mm (in)		303 W x 238 H (11.93 x 9.38)	184 W x 131 H (7.24 x 5.16)	100.5 W x 178.5 H (3.96 x 7.03)
Operating voltage		24 VDC	24 VDC	24 VDC
Max. power		18 W	15 W	7 W
Ratings		NEMA 4	NEMA 4	NEMA 4
Approvals		UL/CSA/CE	UL/CSA/CE	UL/cULus/Class I Div 2

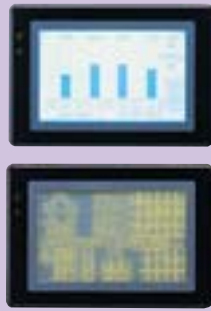

NT600S

NT20S

NT11S

NT2S

Display				
Type	STN, Electroluminescent	Backlit STN LCD	Backlit LCD	Backlit LCD
Size	9 inch diagonal	5 inch diagonal	4 line x 20 character	2 line x 16 character
Resolution	640 x 400 pixels	256 x 128 pixels	160 x 64 pixels	–
Interface	Touch screen	Touch screen	Alphanumeric	6 function keys
Memory				
Type	Flash EPROM	Flash EPROM	Flash EPROM	Flash EPROM
Max. screen storage	500	500	250	250
Features				
Freeform drawing	Yes	Yes	No	No
Bitmap	No	No	No	No
Tiling (color or texture fill)	No	No	No	No
Bar graph	Yes	Yes	Yes	Yes
Needle gauge	No	No	No	No
Line trending	No	No	No	No
Thumbwheel	Yes	Yes	No	No
Bit controlled input lockout	No	No	No	No
Recipe table	No	No	No	No
Math function	No	No	No	No
Programming console	No	No	No	No
Pop-up windows	No	No	No	No
Device monitor function	No	No	No	No
Real time clock	No	No	No	No
Printer port	No	No	Yes	No
Memory unit support	No	No	No	No
Communications				
Host link	Yes	Yes	Yes	Yes
NT link	Yes	Yes	Yes	No
High-speed NT link	No	No	No	No
Allen-Bradley	No	No	No	Yes
GE Fanuc	No	No	No	Yes
Mitsubishi	No	No	No	Yes
Siemens	No	No	No	Yes
Modicon	No	No	No	Yes
Memory Link	No	Yes	No	No
General specifications				
Overall dimensions mm (in)	275 W x 192 H x 71 D (10.83 x 7.56 x 2.80)	190 W x 110 H x 58 D (7.48 x 4.33 x 2.28)	218 W x 113 H x 38.2 D (8.58 x 4.45 x 1.50)	91 W x 44 H x 28 D (3.58 x 1.73 x 1.10)
Panel cutout mm (in)	263.5 W x 180.5 H (10.37 x 7.11)	101 W x 178.5 H (3.98 x 7.03)	98.5 W x 203.5 H (3.87 x 8.01)	45 W x 92 H (1.8 x 3.6)
Operating voltage	24 VDC	24 VDC	24 VDC	5 VDC/24 VDC
Max. power	25 W (EL), 15 W (LCD)	10 W	10 W	0.75 W/1.5 W
Ratings	NEMA 4	NEMA 4	NEMA 4	IP65
Approvals	UL/CSA/CE	UL/CSA/CE	UL/CSA/CE	UL/CSA/CE

Software

NT21/31/631

NT20S/600S

NT11S

NT2S

Technical Highlights

NOTE: Throughout this catalog, many of the product dimensions are shown in both millimeters and inches. When both are not shown, divide millimeters by 25.4 to calculate inches.

NOTE: Specifications subject to change without notice.

Warranty: Omron certifies all of its products either meet or exceed stipulated specifications one year from the date of purchase. Omron is not liable for stenographic and/or clerical errors.

Omron's obligation under this warranty is limited solely to repair or replacement at Omron's discretion. Omron will not be liable for any design furnished by Buyer and incorporated into equipment.

This warranty is voided if the product is altered in any way or suffers consequential damage due to negligence or misuse.

Omron is not to suffer risk due to the suitability or unsuitability or the results of the use of its products used in combination with any electrical or electronic components, circuits, systems, assemblies or any other materials or substances or environments.

The foregoing warranty is the only warranty which Omron Electronics LLC provides with respect to the products listed herein. No other warranties, expressed, implied or statutory shall apply, whether as to merchantability, fitness for a particular purpose, description, or otherwise.

Limitation of Liability: Notwithstanding any other statement herein, Omron Electronics LLC, its contractors and suppliers shall not be liable for any special, indirect, incidental or consequential damages. The remedies of the purchaser set forth herein are exclusive where so stated, and the total cumulative liability of Omron Electronics LLC, its contractors and suppliers, with respect to this contract or anything done in connection therewith, shall not exceed replacement price reimbursement as to the product on which such liability is based.

NT-Series Support Tool Graphic Development Software

- Drag-and-drop, windowed workspace
- Import I/O and comments from CX-Programmer
- Translation Support Utility to manage a project in multiple languages
- Simulation of the ON/OFF states for control objects
- Copy and paste from screen to screen, and project to project
- Tables for managing numeral, string, bit, math, and recipe information
- View and edit bitmap images in the Image Table
- Symbol manager includes ISO 7000 image library
- Use pre-built or customized keypads
- Object alignment tools
- Global address change tool
- Error log with hot links to the error
- 10 levels of undo/redo



Omron's NTST software lets you create, debug and manage operator interface terminal programs in a familiar Windows® environment with drag-and-drop convenience. The short learning curve to produce clear, easy-to-use screens reduces the time to commissioning.

Freedom to Design Screens Your Way

The NT-series HMIs offer unmatched programming flexibility, allowing screens to be designed to meet your control needs. The programming software, NTST, unlocks this flexibility. For instance, some NT models allow memory to be allocated to numeral and string tables based on your needs. Configure objects from the drag-and-drop toolbar and add finishing touches using a variety of drawing tools. A library of standard ISO 7000 symbols can be used to denote actions, items, and conditions. Preconfigured or custom keypads can be integrated for numeric entry. Project data is managed from a series of easily navigated tables for storing numeric, bit, string, image, recipe, and math function data. Control and display objects that reference these tables can utilize indirect addressing, where the PLC can specify the table location to be accessed, allowing one screen object to reference multiple table locations. A parent/child option allows complex screens to be created from parts that can be used over and over again, reducing

programming and utilizing memory more efficiently. Also, addressing in the NT unit is direct to the memory locations within the PLC, regardless of PLC vendor. This allows programs to be created using the addressing schemes familiar to the PLC programmer.

Cut Debugging Time

NTST employs a variety of features that allow programming and debugging time to be compressed. Download one screen at a time to the NT unit to check out new screens or minor edits. Upload individual items such as the different data tables, screens, alarm history and screen history logs, and recipe settings. Object filters in the screen editor allow only a specific object type to be shown, to simplify editing of complex screens. An error log includes hot links to the actual error, so that they can be viewed and corrected quickly. The ON/OFF states and flashing properties of objects can be checked in the programming environment of NTST to avoid simple mistakes in formatting.

Ordering Information

Description	Part Number
NT Series Support Tool v 4.6	NT-ZJCAT1-EV4
Programming Cable 9-9 pin	C200H-CN229-EU

Models Supported

NT Series Support Tool can be used with the following models: NT11S, NT20S, NT30, NT30C, NT21, NT31, NT31C, NT600S, NT620S, NT620C, NT631, NT631C

System Requirements

Computer	Operating System
<ul style="list-style-type: none"> • IBM PC or 100% compatible Pentium 100 MHz or faster processor • 32 Mbytes memory minimum • At least 35 Mbytes free area on hard disk (for installing Support Tool, System Program, System Installer and Supplement Symbols) 	<ul style="list-style-type: none"> • Another 15 MB required for Parts Collection for Support Tool • CD-ROM drive • VGA compatible display • Serial or bus mouse
<p>Microsoft® Windows® 95, Windows® 98, Windows® NT Version 4.0 (Service Pack 3 or later)</p>	<p>RS-232C cable to transmit screen data</p>

Tools to Organize Your Design

NTST takes full advantage of the drag-and-drop, windowed, dialog-box-driven environment. A handy and familiar tree-style project window helps you organize the project. Drop-down menus provide quick access to all programming areas and actions needed to configure a project. A helpful status bar at the bottom of the screen shows the NT touch screen and PLC vendor for this program. A series of tables listed in the Tools menu and project tree allow quick access to numeric, recipe, string, and background math setup information. The project information and programming tools are readily available to make programming and maintaining project from NTST a breeze.

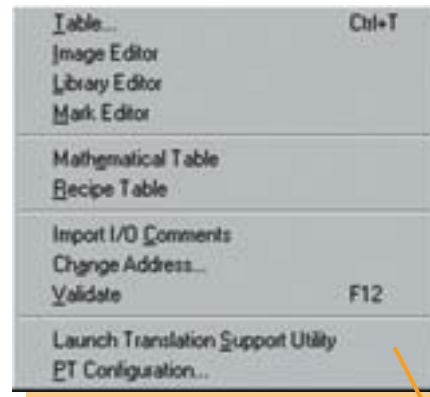

Tools Menu



File Menu

Tree-style Project Menus

Presents project data on an organized, familiar tree structure. Quickly access screens and tables within a project.

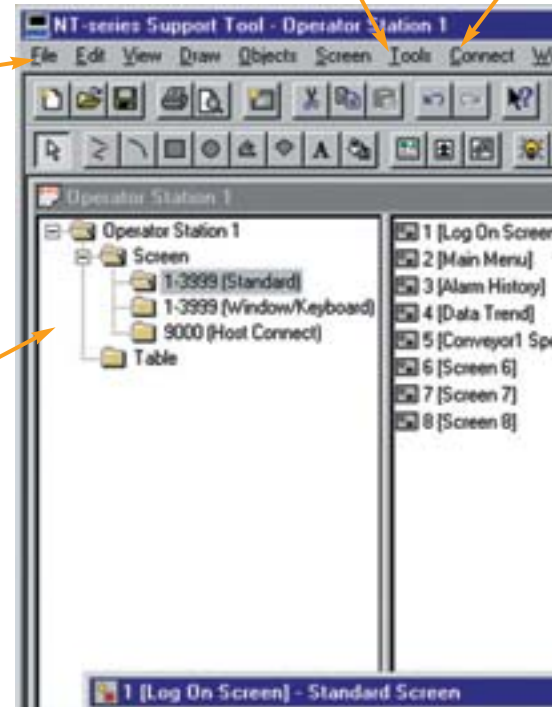

Pre-built Input Keypads

A variety of keypad layouts are available from the Symbol Library included with NTST.

Status Bar

Shows details about the highlighted object. For control objects, critical programming information is shown.

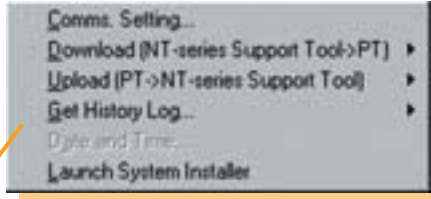

Connect Menu

Label Centering Tool

Centers labels with touch switch and lamp objects.

Drag & Drop Control Object Toolbar

Object Filter

Reduce clutter on a screen in order to edit a buried object of a certain type.

Alignment Tools

Select a group of objects and align them top, bottom, left, right, center vertically or horizontally.

Windowed Environment

Remaining NT Memory/ Total NT Memory

Determine how much more room you have to program in the NT unit's memory.

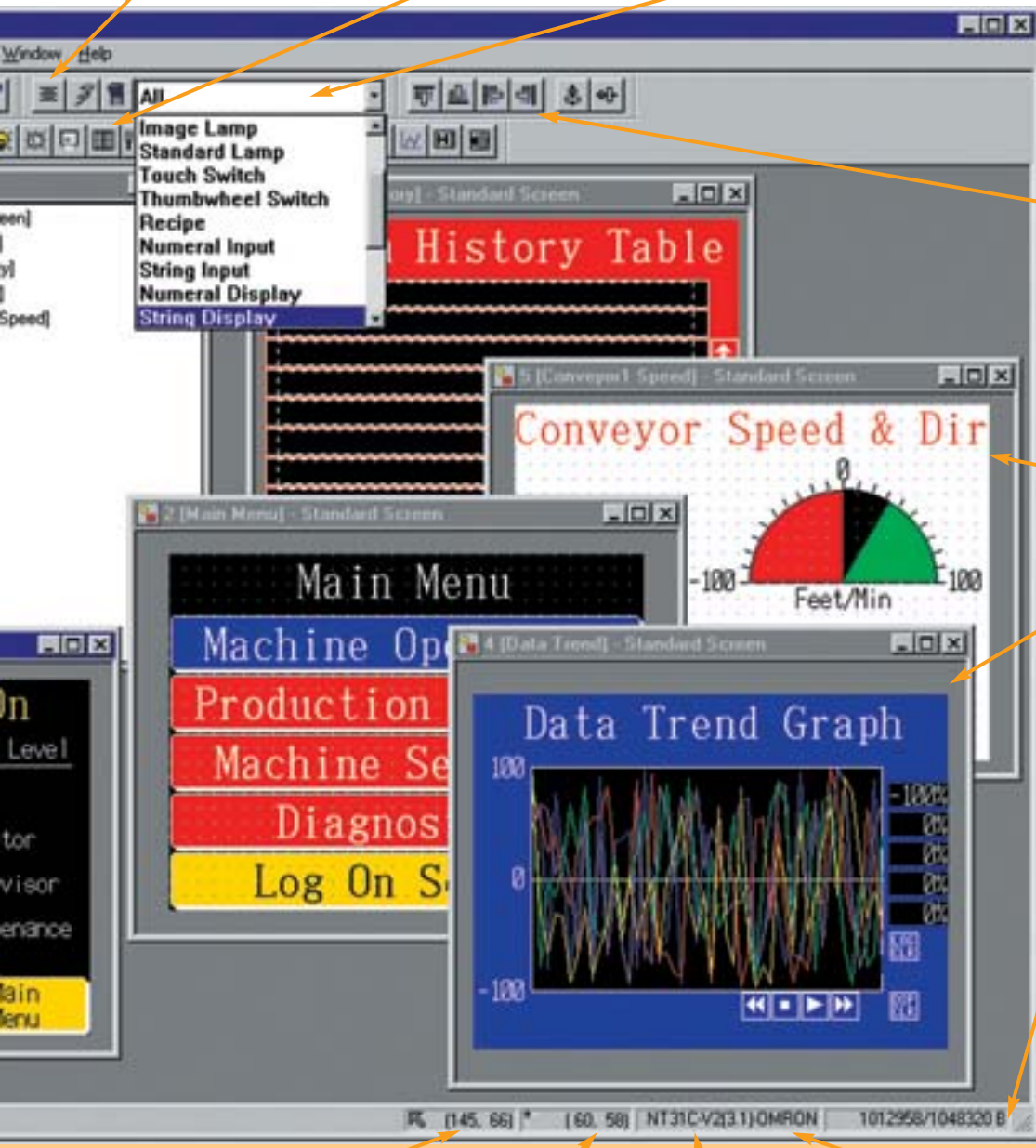

Cursor Position

Top-left Coordinate of Selected Object

Project Model Setting

PLC Vendor

Translation Support Utility

If your equipment is used overseas, the NTST Translation Utility reduces time and costs associated with the translation and maintenance of translated screen projects. After you create a program, import it into the Translation Utility where the text strings will be automatically stripped from the project and displayed in the first column, column A, of a database. Next, create a second column, column B, that will store the new language text. Have the translator simply translate the words in column A into column B. Then a menu command, Generate, is selected to create a new screen project containing the translated text. This can be repeated within the same database for up to six languages.

Works with Most NT-Series Touch Screens

The Translation Utility works with projects developed for NT11S, NT20S, NT21, NT31, NT600, and NT631 touch screens.

Debugging Time and Validation Time Savings

Each new language file is simply the master English file with the English text swapped out for translated text. This means only one master screen project must be maintained. Maintain only one engineering project!

The work of the translator is greatly simplified. The language translation activity can take place in Microsoft Access or Excel, not in NTST. This means your translators do not have to hunt through the screen project trying to locate text strings. It also means your translators do not have to be screen programming experts. If they can read a column of text in Excel, they can translate your entire project!

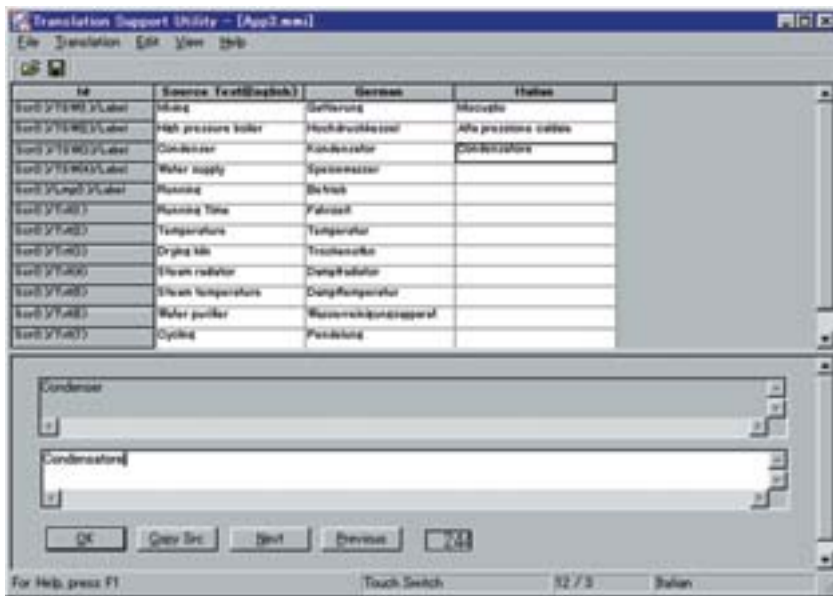

Modifying Existing Programs

Updating the master program is infinitely easier with the NTST Translation Utility. No longer do engineering changes need to be made to the master project and all translated files. Make the engineering changes to the master project and then simply re-import the master project into the existing translation database for that project. The translation support utility automatically compares contents of the new master project to the original import and identifies areas where text changes. Existing translation work is maintained and is automatically reused. New text that requires translation is added to the database. Select Generate once the touch-up translation is complete to create the final translated projects.

Languages

Translation Utility supports these languages:

- English
- Spanish
- French
- Japanese
- Chinese (Simplified and Traditional)
- German
- Italian

System Installer

Quickly update the firmware program of the operator interface using the NTST system installer. This software utility allows programmers to select from a variety of firmware programs for specific NT model types and then transfer the firmware to the NT unit. Use the System Installer to upgrade to newer versions of firmware or download firmware for different communications drivers.

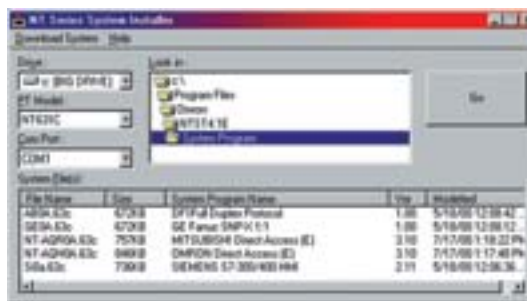

String Table

Data strings tie ASCII data to a PLC memory location for reading or writing, and display in lamps, switches and text blocks. Strings can be referenced from anywhere in the project, including alarm histories and string displays. The string table lets you organize them for easy reference.

Models NT21/31/631 allow string table entries to be expanded from 256 (default) to 1000 or 2000 entries. Larger string tables consume NT memory resources.

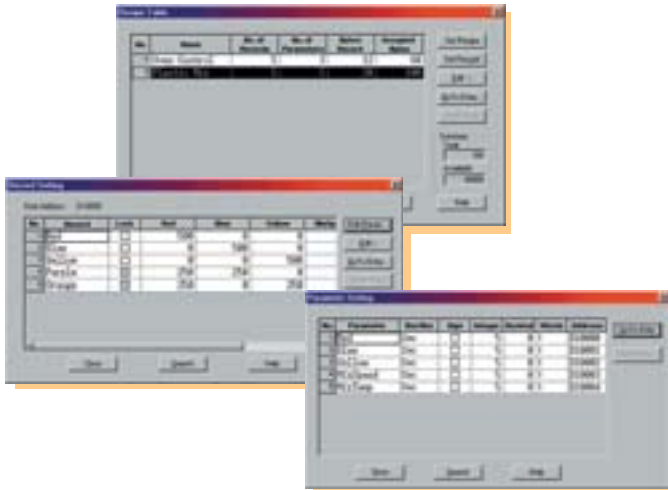
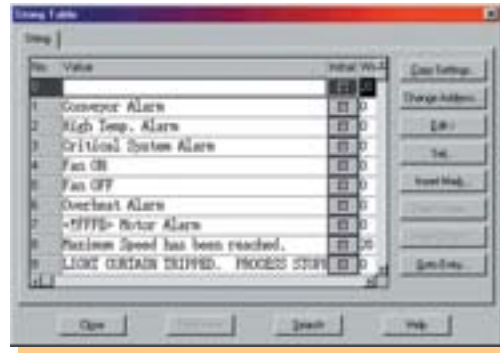

Recipe Table

The recipe table lets the programmer handle many functions:

- Create recipes
- Manage data for recipe objects
- Import and export data to/from the recipe table to a comma separated variable (CSV) file for future reference
- Limit operator access to making changes in recipe parameters
- Choose the link to the PLC data memory
- Configure how data will be displayed for the operator.

The recipe table manages up to 40K bytes of recipe memory.

Math Table

Store customized math equations and Boolean logic in the math table. Use it to process results from PLC data memory or references to the Numeral Table of NT terminals and constant values. Results can go to PLC data memory or the NT's Numeral Table. The math table can convert results into engineering units, scaling the value for display purposes. This eliminates the need for creating math in the PLC that can slow down processing.

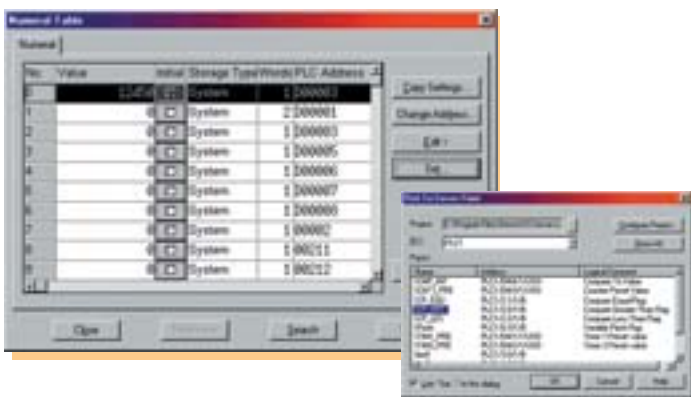
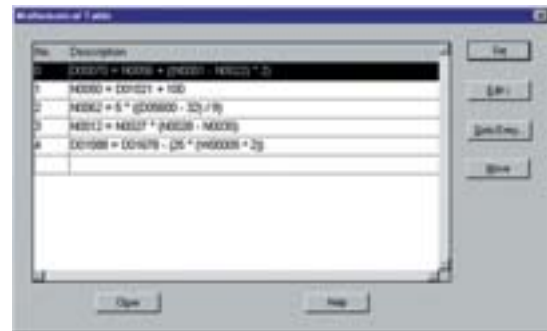

Numeral Table

All screen objects with numbers refer to this table to link back to the PLC memory area. Use the numeral table to organize data and establish initial or default values and format. This table references PLC memory locations to define constant values such as initial set point for timers, counters and temperature controllers. Subsequent data from the PLC resets and updates these values. Models NT21/31/631 allow the numeral table to be increased in size from 512 (default) to 1000 or 2000 entries. Larger numeral tables consume NT memory resources.

NT-Series

High Function Touch Screens NT21 / NT31 / NT631	14 - 21
Basic Function Touch Screens NT20S / NT600S	22 - 25
Large Function Key Unit NT11S	26 - 29
Small Function Key Units NT2S	30 - 33

Give your operators real-time information to control plant floor action using Omron's operator interfaces. Our full line includes small function-key units with flexibility to display critical messages, monitor bit status or enter numeric values. Touch screen models for more demanding applications deliver a wide range of capabilities including trending, alarm history storage, recipes, background math calculations, and input object lockout. Pair up Omron's space-saving operator interfaces with PLCs from Omron, other manufacturers, PC-based control boards, and DeviceNet networks. Omron has the right HMI for your needs.

Software

NT21/31/631

NT20S/600S

NT1S

NT2S

Technical Highlights

Get the Most from Your Omron PLCs

The NT21/NT31/NT631 operator interface products create superior Omron PLC solutions by taking advantage of features that other HMI products simply cannot offer in an Omron system. Our HMI products are designed with the same attention to quality and performance that go into our broad line of industry leading PLCs. Omron's NT21/31/631 also offer significant programming flexibility in object layout and PLC controls, allowing you to create the program needed to realize your operator interface vision.

- **High-Speed NT Link** - This 115 kbaud serial Omron protocol allows rapid data exchange with Omron CJ1 and CS1 PLCs.
- **NT Link 1:N** - At 38.4 and 115 kbaud, NT Link 1:N allows 8 screens to be connected to a single serial port on CJ1 and CS1 PLCs with minimal impact to performance.
- **PLC Programming Console** - Simulate a hand-held programming device right on the HMI screen and monitor, set PLC values, and make minor ladder program changes.
- **PLC Device Monitor** - This function allows the NT31 and NT631 to function as watch windows, where the user can specify and view banks of PLC addresses, change values, and view errors without opening the panel.
- **Pop-Up Windows** - Present up to two pop-up windows at a time on the HMI screen to control critical information in a timely manner.
- **Window Control Area** - Control pop-up windows from the PLC memory by manipulating the window control area.
- **Parent/Child Windows** - Create screen segments that can be used again and again throughout a project. This conserves both screen memory and programming effort.
- Same programming functionality available in 5.2", 5.7", 10.4", and 11.3" screen sizes.
- DeviceNet communication module available for NT31 and NT631.
- Supports multi-vendor communication, allowing Omron touch screens to be the standard HMI.
- Memory module can be set to automatically upload or download both screen data and system firmware.
- Analog data can be displayed in chart, bar graph, and needle gauge objects.
- Binary status can be shown with lamps, animated bitmaps, and alarm bits.



Multi-Vendor Communications

Standardize on Omron's high quality touch screens regardless of which PLC vendors you use. Our drivers and vendor-specific cables allow Omron's NT31 and NT631 touch screens to communicate with the PLCs from the following vendors:

- Omron (CV, CS1, CJ1, CPM1A, CPM2□, SRM1)
- Allen-Bradley (ML1000/1200/1500, SLC 5/00, 5/01, 5/02, 5/03, 5/04, 5/05)
- GE Fanuc Series 90-20 and 90-30 PLCs
- Mitsubishi A and FX series PLCs
- Siemens S7-300 and S7-400 PLCs
- Modicon Micro, Premium, Quantum, Momentum

High-Speed NT Link

High-speed NT Link highlights the advantages that come when you partner an Omron PLC with an Omron touch screen. Combine Omron's CS1-EV1 PLCs with NT21/31/631 to benefit from 115k baud serial communications tailored exclusively for PLC to touch screen data. It is almost twice as fast as Host Link and 25% faster than standard NT Link when a single NT unit is connected to a PLC serial port. High-speed NT Link is three times faster than standard NT Link with 8 NT units connected to a single CS1 or CJ1 serial port.

OMRON Data Comparison

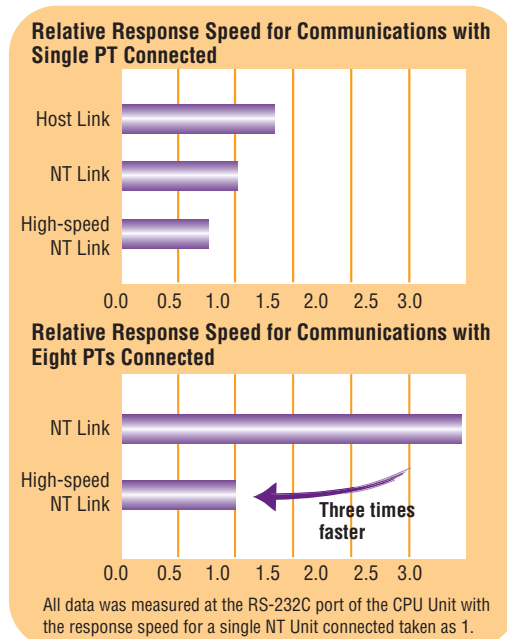

DeviceNet

The NT31 and NT631 can be quickly configured for DeviceNet communications, integrating seamlessly into your open DeviceNet network. This is truly a multi-vendor PLC solution, since no modifications need to be made to the screen data when changing the brand of the DeviceNet master. (See the DeviceNet Technical Discussion in the Technical Highlights of this catalog for detailed specifications.)



NT Link 1:N Communication

This protocol allows multiple interfaces to be connected to one PLC communication port. It is available with both standard and high speed NT Link. This protocol allows you to create a multi-drop system that puts up-to-the-second data at locations along the production line. (See the NT Link section in the Technical Highlights of this catalog for more details and specifications.)

Memory Link

Directly connect the NT with a single board computer, PLC or personal computer via RS-232C or RS-422 communications using Memory Link. This protocol allocates a virtual memory area within the operator interface to store data values. The screen program references this internal memory area for all screen objects, just as though this memory area belonged to a PLC. This means your PC based device only has to be concerned with referencing this memory area to read and write data values. (See the Memory Link section in the Technical Highlights at the end of this catalog for more details.)

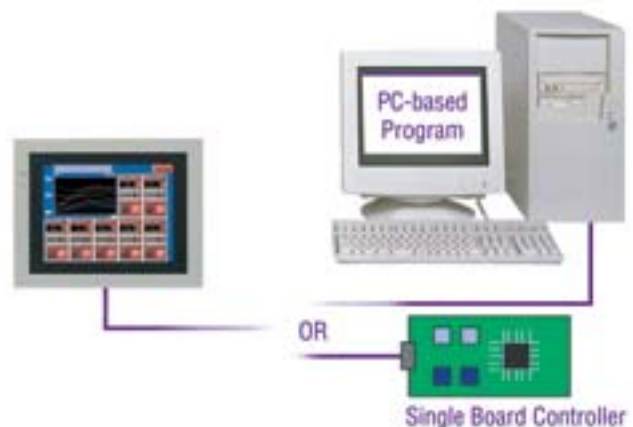

Software

NT21/31/631

NT20S/60S

NT11S

NT2S

Technical Highlights

Recipe Data

Recipes store rows of values within the NT memory and operators can send that information down to the PLC to configure it for a batch operation. The new Recipe Table editor in NTST v4.6 creates and manages recipe information, allowing recipe data to be up- or downloaded from the NT hardware. NTST can also work with comma separated variable files to read in large recipe tables, or store uploaded recipe data for future reference or use.

No.	Cake	Cream	Sugar	Egg	Milk
1	Cheese cake	1000	200	20	200
2	Almond cake	500	200	10	250
3	Fondant cake	1000	200	10	200
4	Carrot cake	500	150	10	250
5	Butter cake	700	150	20	200
6	Apple cake	500	200	5	200
7	Banana cake	500	200	10	150
8	Layer cake	1000	450	10	200
9	Cream cake	1000	200	15	100
10	Coconut cake	0	0	0	0



Background Math Function

NT31/631 units store a Mathematical Table that allows functions of different formats to run in the background of the NT31/631 units. The equations can be constructed of constants, values from NT31/631 memory, or values from PLC memory locations. Calculation results can be sent to NT31/631 internal memory or directly to the PLC memory. Now you can convert values for display purposes within the display device, leaving the PLC to worry about calculations that affect your process.

Input Enable - Bit Interlock Function

This function is suited for use as a password protection function. The interlock function denies access to input objects (touch switches, thumb-wheels, numeric input fields, and string input fields) based on the status of a bit in the PLC. Each input object within an NT31/631-EV2 project can be assigned to a unique bit or the same bit within the PLC. If the bit is ON, the input object will function. Turn the bit OFF and the input object is locked out. An excellent application of this feature would be login security. When the operator enters a password using a keypad, the PLC will compare the entered number to the values in certain PLC memory registers. The PLC can then change the referenced bits from 0 to 1 accordingly, granting access to different screen areas or input objects as designated by the user's access level.



Pop-Up Windows

Two window screens can be displayed in one standard screen, maximizing screen space and application efficiency. All objects (except thumb-wheel switches) can be displayed within these pop-up windows allowing operators to simultaneously view different aspects of the process as needed. Create a variety of pop-up window screens and call them up for display in your application as needed, either manually or from PLC memory.



Alarm History, Frequency, and Activity

Track your process and create a fault record using the alarm history, frequency and activity functions. These pop-up windows graphically convey problems in your process and allow you to make corrections to save time and materials. Simply drag the alarm object into the touch screen project, create a PLC bit reference in an alarm bit table, add a message to that bit, and the NT21/NT31/NT631 are ready to track and report alarms. The complete alarm history and frequency reports can be printed from the system menus.

Memory Unit

This portable FLASH memory module includes two 1MB banks. Each bank can store the screen data from a fully loaded operator interface, or the firmware program for the NT21, NT31 or NT631. The module can be set for manual or automatically triggered upload or download of data. In fact, the module can be configured to first download a new firmware program and then to automatically download new screen data. Imagine how easy it would be to update customers in the field! No PC connection is needed. Just plug on the module, power up the touch screen and transfer the programs.



Programming Console

When using an Omron PLC and NT-Link communications, this feature allows you to adjust mnemonic programming and access, monitor, and change individual memory addresses using the operator interface instead of a laptop or hand-held programmer. Now, maintenance personnel no longer need to carry a hand-held programmer or laptop from PLC to PLC to perform diagnostics. It can be performed right from the front of the operator interface without ever opening the control panel.

Device Monitor Function

Another feature available on the NT31/631 when using an Omron PLC, the Device Monitor Function allows the NT to monitor tables of individually selected PLC values, or entire ranges of a PLC memory area. Once the values or ranges are selected, data values can be viewed in real time as they change. There is also a window to view errors currently active within PLC memory. Previously, only the PLC programming software could perform these diagnostics. Now, no laptop is needed for these basic debugging tools.

Registration Monitor – Manually create a list of PLC addresses and simultaneously monitor them. Update the different values by touching the address and entering a new value with a popup keypad.

PLC Error Screen – View the current errors in the PLC.

Continuous Monitor - Create a table of 50 PLC addresses to monitor and change. Simply select the initial address, and the table automatically fills in with the next (25 for NT31, 50 for NT631) sequential addresses.



Images and Art Objects

Bitmap images can be displayed as fixed objects or image lamps. Image lamps have an ON state and OFF state, each represented by a different bitmap. Image objects display bitmap images from the image table stored within the operator interface. This can be a fixed reference to one image table location, or the reference can be controlled by the PLC. This is an excellent way to quickly achieve animation.

Touch Switches and Lamps

The original purpose of touch screens was to provide a cost effective replacement for hardwired pushbutton and selection switches and indicator lamps. This is still one of the primary motivations on panels today. The NT31 and NT631 include a variety of touch switch and lamps, as well as a library of image objects to lend that special touch. Omron touch switches and lamps include a higher degree of control than most touch screen products, allowing the objects to be sized, colored, and positioned as needed. There are also many labeling options available:

- Control bits
- Control pop-up windows
- Switch screens
- Copy values
- Input numeric & text characters
- Move the cursor
- Execute a screen print



Dynamic Labels

The labels within touch switches and lamps can change with bit state, display a numeric value from PLC memory, or display any number of messages directly from a string table as commanded by the PLC. The string table is a numbered list where each table entry represents a different string message. The PLC can specify a string table entry number and change the message displayed within a switch or lamp, creating a great deal of application flexibility.

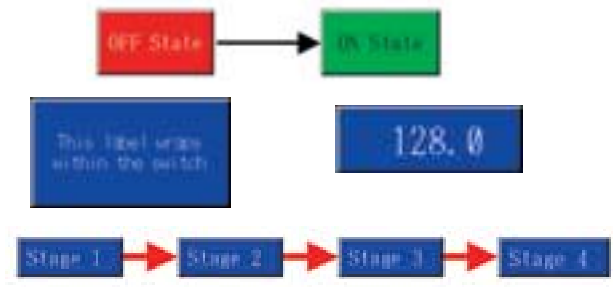

Numeric and String Display

Numeric values can be displayed as bar graphs, needle meters, or simple formatted numerals. All of these options are highly customizable, and can be located anywhere on the screen. Strings can be displayed as alphanumeric characters read from the string table in the operator interface memory as directed by the PLC, or taken directly from PLC memory.

Graphical Data Display

Use colorful charts and graphs to convey complex data to your operators at a glance. Chart data can be logged for review of previous activity.

Communication Ports

The NT31 and NT631 series interfaces have a dedicated printer port, an RS-232C port with a 5vdc pin, and a port that is configured to RS-232C, RS-422/485 (the NT631 uses a terminal block for RS-422/485 connection). The dedicated RS-232C port is generally left available to ensure a free port for program transfer. The dedicated RS-232C port is also available for connection to a bar-code reader (Omron serial driver only). The NT21 series interface has two RS-232C ports. One port can be converted to RS-422/485 using the NS-AL002 adapter.



NT21



NT31



NT631



NT21



NT31



NT631

Compact Design

The shallow depths, efficient face dimensions, and small panel cutout requirements make this NT series ideal for mounting in confined spaces.

Software

NT21/31/631

NT20S/60S

NT11S

NT2S

Technical Highlights

Ordering Information

Description	Part Number
NT21 Display	
Monochrome STN LCD 5.2" touch screen	NT21-ST121□-E
NT21 Accessories	
5 NT21 Protective Screen Sheets	NT20M-KBA04
NT21 Chemical Resistant Cover	NT20S-KBA01
RS232C to RS422A Adapter	NS-AL002
NT31 Display	
Monochrome STN LCD 5.7" touch screen	NT31-ST121□-EV2
8 Color STN LCD 5.7" touch screen	NT31C-ST141□-EV2
NT31 Accessories	
NT30/NT31 Chemical Resistant Cover	NT30-KBA01
5 NT30/NT31 Protective Screen Sheets	NT30-KBA04
NT31/NT31C Replacement Backlight	NT31C-CFL01
50 cm 25-9PIN Cable, NT to Omron PLC	NT31C-CN510-EU
3 m 25-9PIN Cable, NT to Omron PLC	NT31C-CN320-EU
5 m 25-9PIN Cable, NT to Omron PLC	NT31C-CN520-EU
3 m 25-9PIN Cable, NT to AB PLC	NT31C-CN321-EU
3 m 25-9PIN Cable, NT to GE PLC	NT31C-CN322-EU
3 m 25-9PIN Cable, NT to Siemens	NT31C-CN323-EU
3 m 25-9PIN Cable, NT to Mitsu-A	NT31C-CN324-EU
3 m 25-9PIN Cable, NT to Mitsu-FX	NT31C-CN325-EU

Description	Part Number
NT631 Display	
Electroluminescent 10.4" touch screen	NT631-ST211□-EV2
8 Color STN LCD 11.3" touch screen	NT631C-ST141□-EV2
8 Color TFT LCD 10.4" touch screen	NT631C-ST151□-EV2
NT631 Accessories	
NT631C-ST141 Replacement Backlight	NT631C-CFL01
NT631C-ST151 Replacement Backlight	NT631C-CFL02
NT631 Chemical Resistant Cover	NT625-KBA01
5 NT631 Protective Screen Sheets	NT610C-KBA04
General Accessories	
NT Series Support Tool v 4.6	NT-ZJCAT1-EV4
Programming Cable 9-9 pin	C200H-CN229-EU
50 cm 9-9PIN Cable, NT to Omron PLC	C200H-CN510-EU
3 m 9-9PIN Cable, NT to Omron PLC	C200H-CN320-EU
5 m 9-9PIN Cable, NT to Omron PLC	C200H-CN520-EU
2 m 9PIN Cable, NT to AB DH-485 Port	NT631C-CN221-485
3 m 9-9PIN Cable, NT to AB PLC	NT631C-CN321-EU
3 m 9-9PIN Cable, NT to GE PLC	NT631C-CN322-EU
3 m 9-9PIN Cable, NT to Siemens	NT631C-CN323-EU
3 m 9-9PIN Cable, NT to Mitsu-A	NT631C-CN324-EU
3 m Term-25PIN Cable, NT to Mitsu-FX	NT631C-CN325-EU
2 m CS1/CJ1/CPM2C Peripheral Com. Cable	XW2Z-200T-2
5 m CS1/CJ1/CPM2C Peripheral Com. Cable	XW2Z-500T-2
NT to Printer Cable	NT-CNT121
NT31/NT631 Program Transfer Module	NT-MF261
30W, 24 VDC, 1.3 A Power Supply	S82K-03024
50W, 24 VDC, 2.1 A Power Supply	S82K-05024
Operation Manuals	
NT21 Set-Up Manual	V068-E1-1
NT31 Set-Up Manual	V062-E1-1
NT631 Set-Up Manual	V063-E1-1
NT21/31/631 Reference Manual	V069-E1-1

NT21 Dimensions

mm (inches)

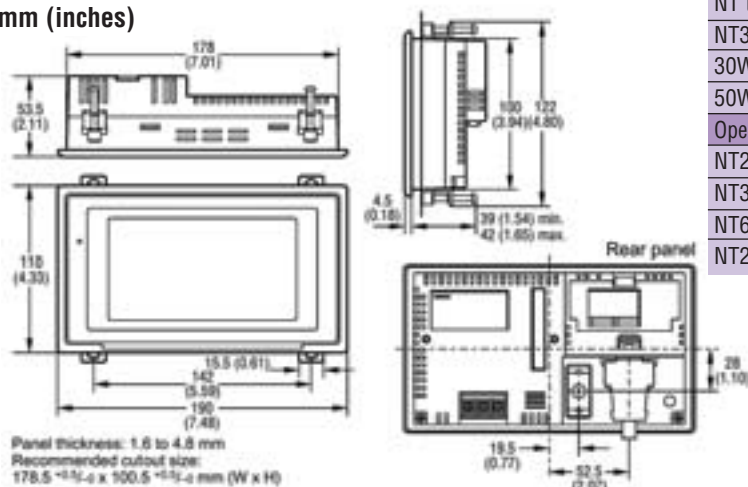

NT31 Dimensions

mm (inches)

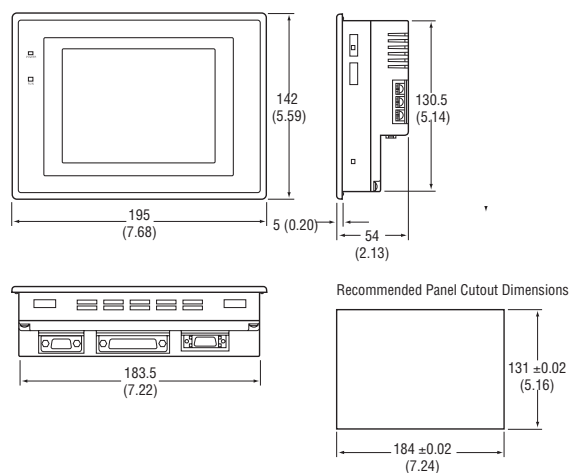

NT631 Dimensions

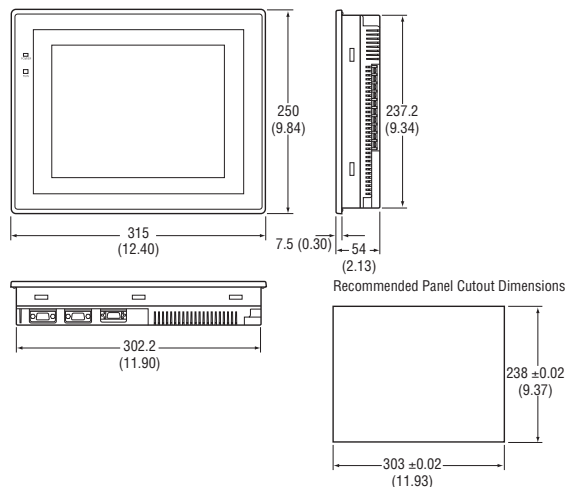

Software

NT21/31/631

NT20S/600S

NT11S

NT2S

Technical Highlights

Specifications

	NT21	NT31/31C	NT631/631C
Rated power supply voltage	24 VDC		
Power consumption	7 W max.	15 W max.	ST211□ 30 W max.; ST141□ & ST151□ 18 W max.
Operating ambient temperature	0 to +50°C (with no icing)	0 to +50°C	ST211□ & ST151□ 0 to +50°C; ST141□: 0 to +40°C
Operating ambient humidity	35 to 85% (0 to 40°C) 35 to 60% (40 to 50°C) (with no condensation)	35% to 85% (with no condensation)	
Noise resistance	Conforms to IEC61000-4-4; Power supply line: 2 kV	Common mode: 1000 Vp-p (between power supply terminals & panel); Normal mode: 300 Vp-p; Pulse width of 100 ns to 1 μs, pulse rise time of 1 ns	
Vibration resistance (operating)	10 to 57 Hz with 0.075 mm amplitude; 57 to 150 Hz with 1G (9.8 m/s ²) acceleration for 60 min. in each of X, Y, Z directions	10 to 57 Hz with 0.075 mm amplitude; 57 to 150 Hz with 1G (9.8 m/s ²) acceleration for 60 min. in each of X, Y, Z directions	ST211□: 10 to 57 Hz with 0.075 mm amplitude for 30 min. in each of X, Y, Z directions; ST141□ & ST151□: 10 to 57 Hz with 0.075 mm amplitude, 57 to 150 Hz with 1G (9.8 m/s ²) acceleration for 30 min. in each of X, Y, Z directions
Shock resistance (operating)	147 m/s ² (15G); 3 times in each of X, Y, Z directions		
Dimensions	190 (W) x 110 (H) x 53.5 (D) mm (thickness inside panel: 49 mm)	195 (W) x 142 (H) x 54 (D) mm (w/ expansion unit: 74 D)	315 (W) x 250 (H) x 54 (D) mm (w/ expansion unit: 74 D)
Weight	0.6 kg max.	1 kg max.	2.5 kg max.
Enclosure ratings	Front panel: equivalent to IP65F (NEMA4)*		
Display panel		Monochrome or Color STN LCD with backlight	ST211□: EL (monochrome); ST141□: Color STN LCD with backlight; ST151□: Color TFT LCD with backlight
Number of dots (resolution)	260 dots horizontally x 140 dots vertically	320 dots horizontally x 240 dots vertically	640 dots horizontally x 480 dots vertically
Effective display area	117 (H) x 63 (V) mm (5.2 inches diagonal)	118.2 (H) x 89.4 (V) mm (5.7 inches diagonal)	ST211□ & ST151□: 211 (H) x 158 (V) mm (10.4 inches diagonal) ST141□: 229 (H) x 172 (V) mm (11.3 inches diagonal)
View angle	Left/right direction: 30°; Up/down: 30°	NT31: Up: 20, Down: 30, Left/right: 30; NT31C: Up: 45, Down: 60, Left/right: 50	ST211□: No restriction; ST141□: Up/down: 30, Left: 55, Right: 45; ST151□: Up: 40, Down: 55, Left/right: 55
Display color	ST121□: 2 color black/white	ST121□: 2 color black/white; ST141□: 8 color	ST211□: 2 color black/gold; ST141□ & ST151□: 8 color
Life expectancy	50,000 hours minimum	50,000 hours minimum	ST211□: 30,000 hrs min.; ST141□ & ST151□: 50,000 hrs min.
Contrast adjustment	Knob on back of unit	NT31 & NT631-ST141□ only: Adj. in 100 levels by touch switch operation at panel	
Max. number of registered screens	3999 screens		
Backlight			
Life expectancy	50,000 hours min.	25,000 hours min.	ST141□: 25,000 hours min.; ST151□: 30,000 hours min.
Replacement	Non-replaceable	NT31, NT631-ST141□ & NT631-ST151□: Can be replaced from the rear	
Brightness adjustment	–	NT31 & NT631-ST141□ only: Adj. in 3 levels by operation at the touch panel	
Automatic turn-off function	Can be set to turn off in 1 to 255 minutes, or to remain on with screen saver		
Touch panel			
Type	Resistive type		
Number of switches	91 (13 horizontally x 7 vertically)	192 (16 horizontally x 12 vertically)	768 (32 horizontally x 24 vertically)
Max. number registered on one screen	91	192	256
Life expectancy	One million operations minimum		
Serial communication			
Serial port A	Conforms to EIA RS-232C; D-SUB 9-pin connector (female); +5 V (250 mA max.) output at pin No. 6		
Serial port B	Conforms to EIA RS-232C; D-SUB 9-pin connector (female); +5 V (250 mA max.) output at pin No. 6	EIA RS-232C or RS-422A/485 (selectable, by memory switch setting); D-SUB 25-pin connector (female)	EIA RS-232C (serial port B terminal block selectable by memory switch setting); D-SUB 9-pin connector (female)
Serial port B terminal	–	–	EIA RS-422A/485 (serial port B connector selectable by memory switch setting); Terminal block
Battery backup	Numeral/character string memory tables data in the NT unit; Alarm history data table in the NT unit; Recipe tables in the NT unit; Real time clock and calendar (NT31/31C/631/631C only)		
Screen print function	–	"ESC/P", "Color": Color printing conforming to ESC/P 24-J83C; "PC-PR201H", "Color": Color printing conforming to PC-PR201PL; "ESC/P", "Tone": Monochrome printing in 8 grayscale levels, conforming to ESC/P 24-J82; "PC-PR201H", "Tone": Monochrome printing in 8 grayscale levels, conforming to PC-PR201PL; "PCL-5", "Tone": Monochrome printing in 8 grayscale levels, conforming to PCL 5; however, the NT31 & NT631 supports monochrome printing only	
Calendar & clock function	–	Displays the current time in accordance with the built-in clock; Displayed and set with "Calendar Check" in the MAINTENANCE MODE" menu	

Software

NT21/31/631

T20S/60S

NT1S

NT2S

Technical Highlights

NT20S

- 5" Monochrome LCD w/Blue pixels
- 5" Monochrome LCD w/Black pixels
- 256x128 pixel resolution
- 72 touch cells per screen
- 96 K program memory
- 500 screen capacity
- Field replaceable backlight
- 54 mm (2.1") panel depth
- Ratings: UL/CE/CSA, NEMA 4

NT600S

- 9" Monochrome LCD w/Blue pixels
- 9" Electroluminescent Display
- 640x400 pixel resolution
- 128 touch cells per screen
- 128 K program memory
- 500 screen capacity
- Field replaceable backlight
- Ratings: UL/CE/CSA, NEMA 4

The NT20S and NT600S operator interfaces provide basic touch screen functionality in compact, low-cost packages providing the basic elements required for control. These elements include touch switches, lamps, numeric and string displays, bar graphs, numeric keypads, and thumb-wheels. Screen programs are created in a graphical drag-and-drop environment using the NT-Series Support Tool (NTST).



NT600S



NT20S

Field Replaceable Backlight

Minimize downtime and reduce cost of ownership with the NT20S and NT600S field replaceable backlights. Open the control panel, remove one screw and pull out the backlight unit. It is as simple as that. There is no need to remove the NT unit from the panel for servicing. Service the backlight right there on the spot.

Touch Switches and Lamps

Create touch switches that are as small as the actual touch cell, or as large as the entire screen. Shadow effect can be added to a touch switch. Lamps can be set to any size on the screen. Square or circular lamps can be created. Added text to both touch switch and lamp objects.



Static Screen Text

Choose from a variety of different font sizes. Display the text as an inverse image. Flash the text to draw attention to a message. Select different ratios of text height to width.

Keypad Numeric Input

Enter numeric values into PLC data memory areas. Specify the data memory area in the NTST numeral table. Thumb-wheel object mimics the input of a traditional thumb-wheel device. Default numeric entry keypad automatically appears at the bottom of the screen. It can input values to multiple numeric fields. Set high and low limits for each numeric input.



Numeric and String Display

Use standard numeric display to show number value. String display field can display ASCII message strings from the PLC memory.

Bar Graphs

Bar graphs can display numeric values graphically. Set the max. value of the bar graph so that a full bar graph conveys the proper message for the process. Resize the bar graphs and display in horizontal and vertical orientations. Configure bar graphs to fill up, down, left, or right.

Software

NT21/31/631

NT20S/600S

NT11S

NT2S

Technical Highlights

Communication Options

Connect the NT20S and NT600S to a PLC using Host Link, NT Link 1:1, and NT Link 1:N to a custom controller using a Serial Link protocol. Protocols are designed for high-speed operation, updating bit, numeric, and string data immediately for display or control purposes. Fast updates and quick response times are guaranteed.

NT Link 1:1

NT Link, an Omron proprietary protocol, is optimized to provide fast and reliable communication between a single NT unit and PLC. Omron uses a 9-pin RS-232C serial cable to connect one NT to a PLC serial port, referred to as a 1:1 connection. It is possible to connect multiple screens to multiple serial ports on the same PLC using 1:1 connections as shown to the right.

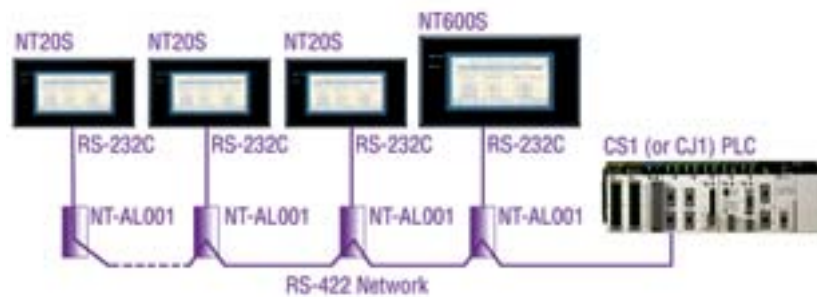

NT Link 1:N

The NT Link protocol can also be used to connect multiple touch screens to a single PLC serial port. Eight screens can be connected to a single serial port on the PLC, reducing the need for additional PLCs or serial port modules. NT Link 1:N provides extremely fast operation even with 4 screens communicating simultaneously over an RS-422A network. The diagram highlights how NT20S and NT600S units can be connected using NT Link 1:N. (See the NT Link section in Technical Highlights for more detailed information.)

Serial Link

The NT20S-ST128 is designed to communicate with the serial port of any custom controller programmed in Visual Basic, C, C++, etc. It is an excellent fit for a custom built solutions that require rugged, industrial operator interfaces. The serial device sends and receives data from the NT20S using a special ASCII commands set. Once the serial device's program is complete, the NT20S can be customized quickly to meet new customer demands.

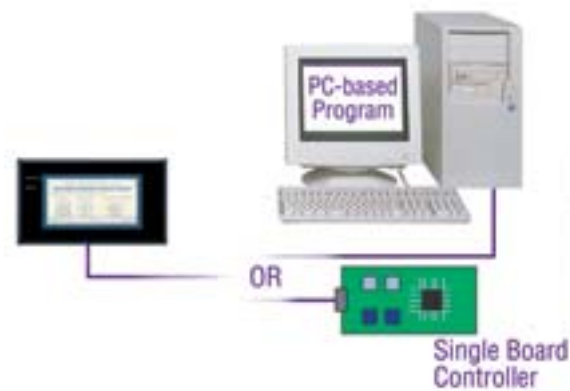

Ordering Information

Description	Part Number
NT20S Display	
Blue LCD 5" backlit touch screen - ivory	NT20S-ST121-EV3
Blue LCD 5" backlit touch screen - black	NT20S-ST121B-EV3
Black LCD 5" backlit touch screen - ivory	NT20S-ST161-EV3
Black LCD 5" backlit touch screen - black	NT20S-ST161B-EV3
Blue LCD 5" touch screen - serial link - black	NT20S-ST128B
NT20S Accessories	
Chemical Resistant Cover	NT20S-KBA01
Protective Screen Sheets	NT20M-KBA04
Backlight	NT20S-CFL01
NT600S Display	
9" LCD touch screen - ivory	NT600S-ST121-EV3
9" LCD touch screen - black	NT600S-ST121B-EV3
9" Electroluminescent touch screen - ivory	NT600S-ST211-EV3
9" Electroluminescent touch screen - black	NT600S-ST211B-EV3

Description	Part Number
NT600S Accessories	
Chemical Resistant Cover	NT600S-KBA01
Protective Screen Sheets	NT600M-KBA04
Backlight	NT600S-CFL01
Battery	3G2A9-BAT08
General Accessories	
NT Series Support Tool v 4.6	NT-ZJCAT1-EV4
Programming Cable 9-9 pin	C200H-CN229-EU
50 cm 9-9PIN Cable, NT to PLC	C200H-CN510-EU
3 m 9-9PIN Cable, NT to PLC	C200H-CN320-EU
5 m 9-9PIN Cable, NT to PLC	C200H-CN520-EU
2 m CS1/CJ1/C2PMC Peripheral Com Cable	XW2Z-200T-2
5 m CS1/CJ1/C2PMC Peripheral Com Cable	XW2Z-500T-2
RS232/422 Converter	NT-AL001
Operation Manuals	
NT20S Operation Manual	V020-E3-1
NT600S Operation Manual	V022-E3-1

Specifications

	NT20S	NT600S
Rated power supply voltage	24 VDC	
Power consumption	10 W max.	ST121: 24V, less than 15 W; ST211: 24V, less than 25 W
Operating ambient temperature	0 to +50°C (with no freezing)	
Operating ambient humidity	35% to 85% RH (with no condensation)	
Resistance to electrostatic discharge	Level 3 (IEC801-2); In air ±8 kV, contact ±6 kV, indirect ±7 kV	
Electromagnetic field strength	10 V/m (IEC801-3)	
Fast transient/burst noise	Power supply line: 2 kV (IEC801-4); I/O line: 0.25 kV	
Damped oscillatory wave	Power supply line: 1 kV (IEC255-4)	
Vibration resistance	10 to 22 Hz with 1.5 mm double amplitude for a total of 30 min. in X, Y, Z directions; 22 to 500 Hz with 1.5 G (14.7 m/s ²) acceleration in X, Y, Z directions	
Shock resistance	Durability: 30 G, 3 times each in X, Y, Z directions; Malfunction: 20 G, 3 times each in X, Y, Z directions	
Dimensions	190 (W) x 110 (H) x 58 (D) mm	275 (W) x 192 (H) x 71 (D) mm
Weight	0.7 kg max.	1.8 kg max.
Enclosure ratings	Front panel: equivalent to IP65 (front face waterproof construction)	
Display panel	STN Liquid Crystal Display (LCD) with backlight	
	EL (monochrome) or Color STN LCD with backlight	
Number of dots (resolution)	256 dots horizontally x 128 dots vertically	640 dots horizontally x 400 dots vertically
Effective display area	Blue mode (ST121□): 112 mm horizontally x 56 mm vertically; Monochrome mode (ST161□): 5 inches diagonal	192 mm horizontally x 120 mm vertically
View angle	Left/right direction: ±35°	STN: Left: 50°, Right: 40°; EL: Left/right: 80°
Life expectancy	50,000 hours minimum	STN: 50,000 hrs min.; EL: 30,000 hrs min. (till brightness becomes 30% weaker)
Max. number of registered screens	495	1000 max.
Backlight		
Life expectancy	10,000 hours minimum (average: 20,000 hours)*1	STN: average: 20,000 hours (the time taken for the brightness to decline to half its original value at normal temperature and humidity)
Touch panel		
Number of switches	Max. 72 registerable per screen (12 horizontally x 6 vertically)	
Life expectancy	One million operations minimum	
Serial communication		
Serial port	EIA RS-232C; 9-pin, D-SUB connector (female)	

*1: This is the time it takes for the brightness to decline half its original value under normal temperature and humidity conditions.

NT20S Dimensions

mm (inches)

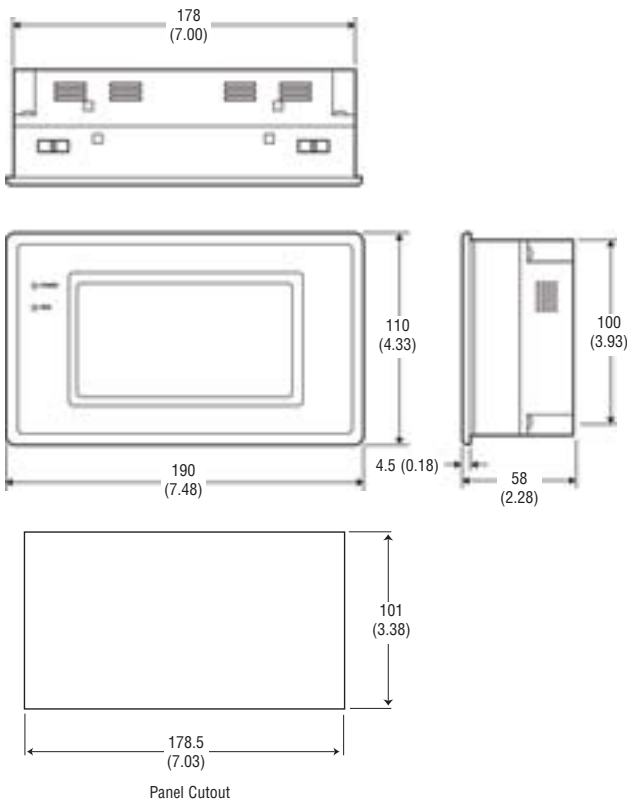

NT600S Dimensions

