



Chipsmall Limited consists of a professional team with an average of over 10 year of expertise in the distribution of electronic components. Based in Hongkong, we have already established firm and mutual-benefit business relationships with customers from,Europe,America and south Asia,supplying obsolete and hard-to-find components to meet their specific needs.

With the principle of “Quality Parts,Customers Priority,Honest Operation,and Considerate Service”,our business mainly focus on the distribution of electronic components. Line cards we deal with include Microchip,ALPS,ROHM,Xilinx,Pulse,ON,Everlight and Freescale. Main products comprise IC,Modules,Potentiometer,IC Socket,Relay,Connector.Our parts cover such applications as commercial,industrial, and automotives areas.

We are looking forward to setting up business relationship with you and hope to provide you with the best service and solution. Let us make a better world for our industry!



Contact us

Tel: +86-755-8981 8866 Fax: +86-755-8427 6832

Email & Skype: info@chipsmall.com Web: www.chipsmall.com

Address: A1208, Overseas Decoration Building, #122 Zhenhua RD., Futian, Shenzhen, China



NTB0104

Dual supply translating transceiver; auto direction sensing;
3-state

Rev. 4 — 19 April 2018

Product data sheet

1. General description

The NTB0104 is a 4-bit, dual supply translating transceiver with auto direction sensing, that enables bidirectional voltage level translation. It features two 4-bit input-output ports (An and Bn), one output enable input (OE) and two supply pins ($V_{CC(A)}$ and $V_{CC(B)}$). $V_{CC(A)}$ can be supplied at any voltage between 1.2 V and 3.6 V and $V_{CC(B)}$ can be supplied at any voltage between 1.65 V and 5.5 V, making the device suitable for translating between any of the low voltage nodes (1.2 V, 1.5 V, 1.8 V, 2.5 V, 3.3 V and 5.0 V).

Pins An and OE are referenced to $V_{CC(A)}$ and pins Bn are referenced to $V_{CC(B)}$. A LOW level at pin OE causes the outputs to assume a high-impedance OFF-state. This device is fully specified for partial power-down applications using I_{OFF} . The I_{OFF} circuitry disables the output, preventing the damaging backflow current through the device when it is powered down.

2. Features and benefits

- Wide supply voltage range:
 - ◆ $V_{CC(A)}$: 1.2 V to 3.6 V and $V_{CC(B)}$: 1.65 V to 5.5 V
- I_{OFF} circuitry provides partial Power-down mode operation
- Inputs accept voltages up to 5.5 V
- ESD protection:
 - ◆ HBM JESD22-A114E Class 2 exceeds 2500 V for A port
 - ◆ HBM JESD22-A114E Class 3B exceeds 15000 V for B port
 - ◆ MM JESD22-A115-A exceeds 200 V
 - ◆ CDM JESD22-C101E exceeds 1500 V (For NTB0104UK 1000 V)
- Latch-up performance exceeds 100 mA per JESD 78B Class II
- Multiple package options
- Specified from $-40\text{ }^{\circ}\text{C}$ to $+85\text{ }^{\circ}\text{C}$ and $-40\text{ }^{\circ}\text{C}$ to $+125\text{ }^{\circ}\text{C}$



3. Ordering information

Table 1. Ordering information

| Type number | Topside marking | Package | | |
|-------------|-----------------|----------|--|-----------|
| | | Name | Description | Version |
| NTB0104BQ | B0104 | DHVQFN14 | plastic dual in-line compatible thermal enhanced very thin quad flat package; no leads; 14 terminals; body 2.5 × 3 × 0.85 mm | SOT762-1 |
| NTB0104GU12 | t4 | XQFN12 | plastic, extremely thin quad flat package; no leads; 12 terminals; body 1.70 × 2.0 × 0.50 mm | SOT1174-1 |
| NTB0104UK | t04 | WLCSP12 | wafer level chip-size package, 12 bumps; body 1.20 × 1.60 × 0.56 mm. (Backside Coating included) | NTB0104UK |

3.1 Ordering options

Table 2. Ordering options

| Type number | Orderable part number | Package | Packing method | Minimum order quantity | Temperature |
|-------------|-----------------------|----------|--|------------------------|--------------------------------------|
| NTB0104BQ | NTB0104BQ,115 | DHVQFN14 | REEL 7" Q1/T1 *STANDARD MARK SMD | 3000 | T _{amb} = -40 °C to +125 °C |
| NTB0104GU12 | NTB0104GU12,115 | XQFN12 | REEL 7" Q1/T1 *STANDARD MARK SMD | 4000 | T _{amb} = -40 °C to +125 °C |
| NTB0104UK | NTB0104UK,012 | WLCSP12 | REEL 7" Q1/T1 *SPECIAL MARK CHIPS DP | 5000 | T _{amb} = -40 °C to +125 °C |

4. Functional diagram

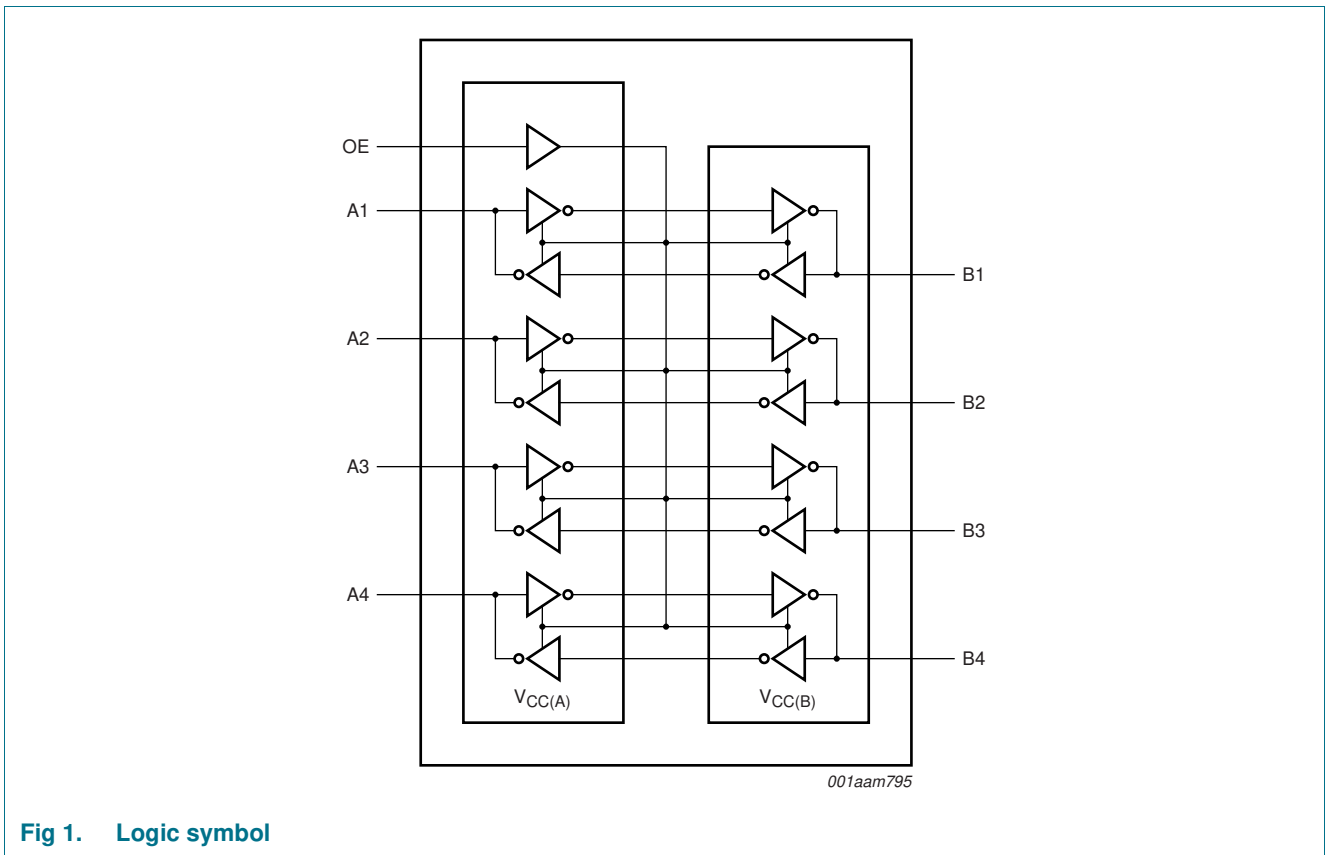
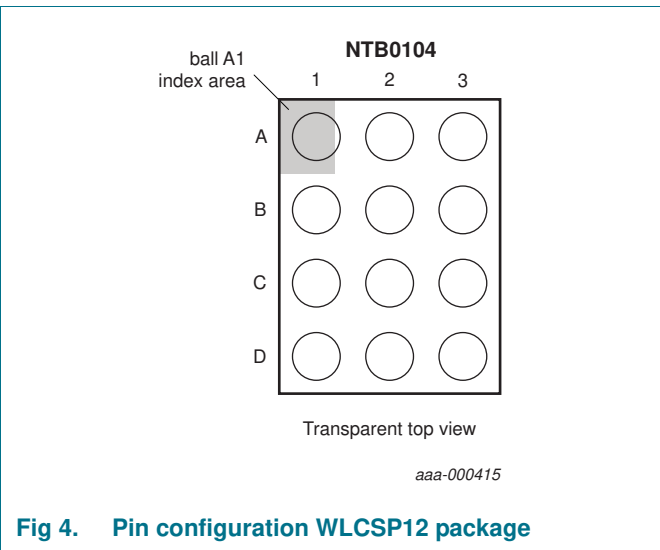
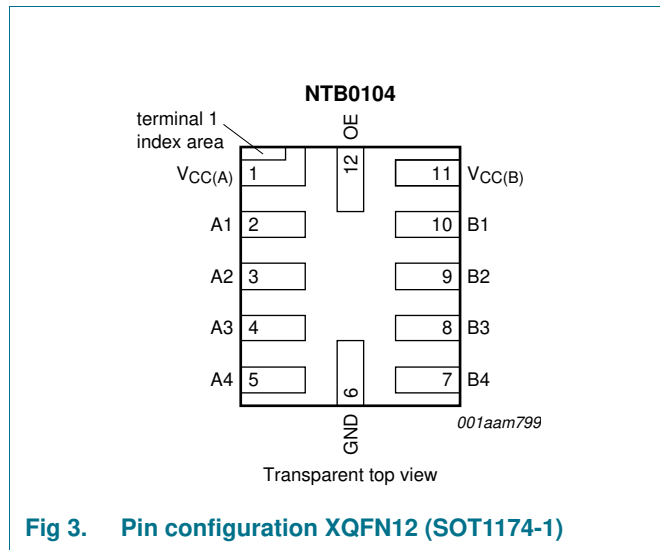
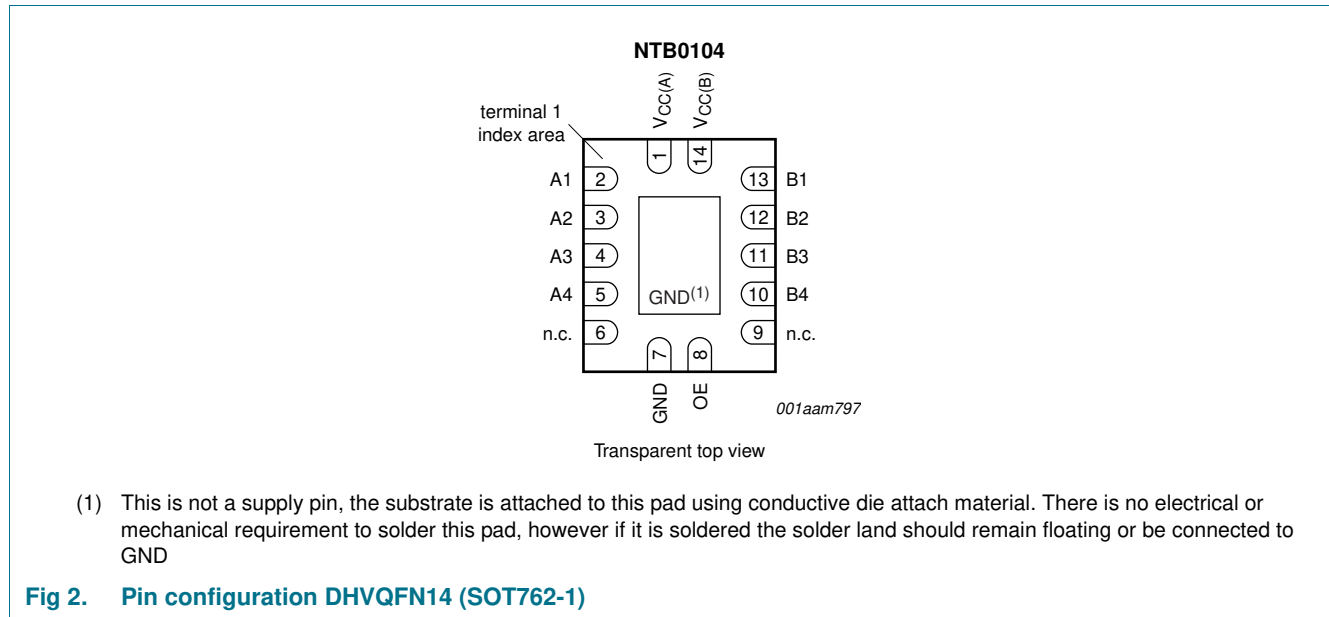

Fig 1. Logic symbol

5. Pinning information

5.1 Pinning



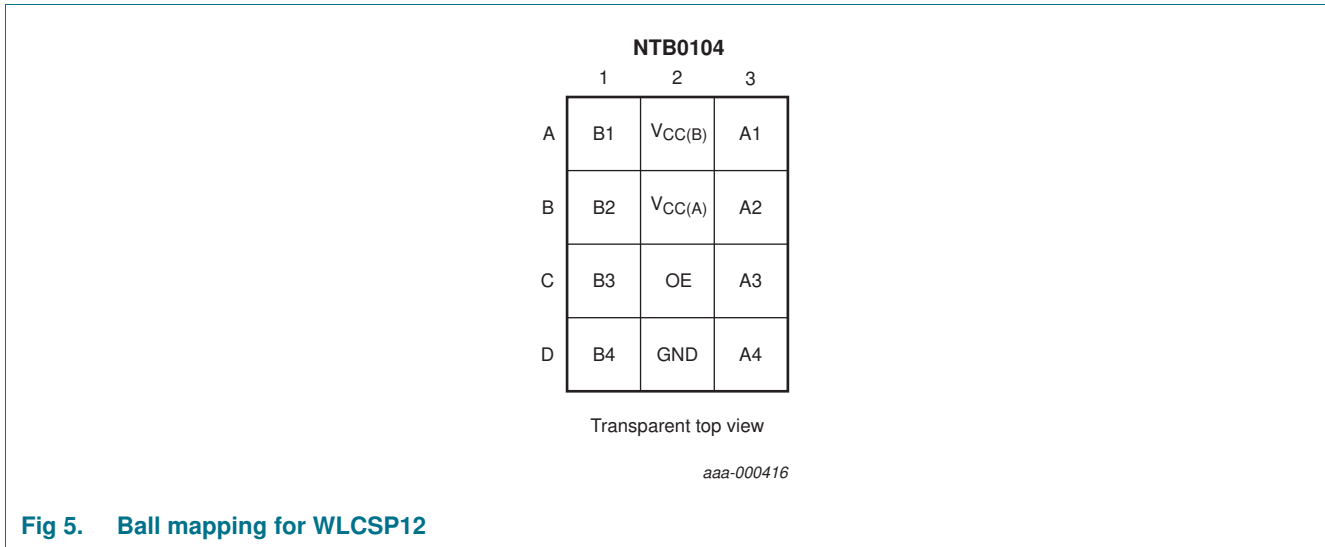

Fig 5. Ball mapping for WLCSP12

5.2 Pin description

Table 3. Pin description

| Symbol | Pin | | Ball | Description |
|----------------|----------------|-------------|----------------|---|
| | SOT762-1 | SOT1174-1 | WLCSP12 | |
| $V_{CC(A)}$ | 1 | 1 | B2 | supply voltage A |
| A1, A2, A3, A4 | 2, 3, 4, 5 | 2, 3, 4, 5 | A3, B3, C3, D3 | data input or output (referenced to $V_{CC(A)}$) |
| n.c. | 6, 9 | - | - | not connected |
| GND | 7 | 6 | D2 | ground (0 V) |
| OE | 8 | 12 | C2 | output enable input (active HIGH; referenced to $V_{CC(A)}$) |
| B4, B3, B2, B1 | 10, 11, 12, 13 | 7, 8, 9, 10 | D1, C1, B1, A1 | data input or output (referenced to $V_{CC(B)}$) |
| $V_{CC(B)}$ | 14 | 11 | A2 | supply voltage B |

6. Functional description

Table 4. Function table^[1]

| Supply voltage | | Input | Input/output | |
|----------------------|--------------------|-------|-----------------|-----------------|
| $V_{CC(A)}$ | $V_{CC(B)}$ | OE | An | Bn |
| 1.2 V to $V_{CC(B)}$ | 1.65 V to 5.5 V | L | Z | Z |
| 1.2 V to $V_{CC(B)}$ | 1.65 V to 5.5 V | H | input or output | output or input |
| GND ^[2] | GND ^[2] | X | Z | Z |

[1] H = HIGH voltage level; L = LOW voltage level; X = don't care; Z = high-impedance OFF-state.

[2] When either $V_{CC(A)}$ or $V_{CC(B)}$ is at GND level, the device goes into power-down mode.

7. Limiting values

Table 5. Limiting values

In accordance with the Absolute Maximum Rating System (IEC 60134). Voltages are referenced to GND (ground = 0 V).

| Symbol | Parameter | Conditions | | Min | Max | Unit |
|-------------|-------------------------|-------------------------------|-----------|------|-----------------|------|
| $V_{CC(A)}$ | supply voltage A | | | -0.5 | +6.5 | V |
| $V_{CC(B)}$ | supply voltage B | | | -0.5 | +6.5 | V |
| V_I | input voltage | | [1] | -0.5 | +6.5 | V |
| V_O | output voltage | Active mode | [1][2][3] | -0.5 | $V_{CCO} + 0.5$ | V |
| | | Power-down or 3-state mode | [1] | -0.5 | +6.5 | V |
| I_{IK} | input clamping current | $V_I < 0$ V | | -50 | - | mA |
| I_{OK} | output clamping current | $V_O < 0$ V | | -50 | - | mA |
| I_O | output current | $V_O = 0$ V to V_{CCO} | [2] | - | ± 50 | mA |
| I_{CC} | supply current | $I_{CC(A)}$ or $I_{CC(B)}$ | | - | 100 | mA |
| I_{GND} | ground current | | | -100 | - | mA |
| T_{stg} | storage temperature | | | -65 | +150 | °C |
| P_{tot} | total power dissipation | $T_{amb} = -40$ °C to +125 °C | [4] | - | 250 | mW |

[1] The minimum input and minimum output voltage ratings may be exceeded if the input and output current ratings are observed.

[2] V_{CCO} is the supply voltage associated with the output.

[3] $V_{CCO} + 0.5$ V should not exceed 6.5 V.

[4] For DHVQFN14 packages: above 60 °C the value of P_{tot} derates linearly with 4.5 mW/K.
For XQFN12 packages: above 128 °C the value of P_{tot} derates linearly with 11.5 mW/K.

8. Recommended operating conditions

Table 6. Recommended operating conditions[1][2]

| Symbol | Parameter | Conditions | | Min | Max | Unit |
|---------------------|-------------------------------------|---|--|------|------|------|
| $V_{CC(A)}$ | supply voltage A | | | 1.2 | 3.6 | V |
| $V_{CC(B)}$ | supply voltage B | | | 1.65 | 5.5 | V |
| V_I | input voltage | | | 0 | 5.5 | V |
| V_O | output voltage | Power-down or 3-state mode; $V_{CC(A)} = 1.2$ V to 3.6 V; $V_{CC(B)} = 1.65$ V to 5.5 V | | | | |
| | | A port | | 0 | 3.6 | V |
| | | B port | | 0 | 5.5 | V |
| T_{amb} | ambient temperature | | | -40 | +125 | °C |
| $\Delta t/\Delta V$ | input transition rise and fall rate | $V_{CC(A)} = 1.2$ V to 3.6 V; $V_{CC(B)} = 1.65$ V to 5.5 V | | - | 40 | ns/V |

[1] The A and B sides of an unused I/O pair must be held in the same state, both at V_{CCI} or both at GND.

[2] $V_{CC(A)}$ must be less than or equal to $V_{CC(B)}$.

9. Static characteristics

Table 7. Typical static characteristics

At recommended operating conditions; voltages are referenced to GND (ground = 0 V); $T_{amb} = 25\text{ }^{\circ}\text{C}$.

| Symbol | Parameter | Conditions | Min | Typ | Max | Unit |
|-----------|---------------------------|--|-----|------|---------|---------------|
| V_{OH} | HIGH-level output voltage | A port; $V_{CC(A)} = 1.2\text{ V}$; $I_O = -20\text{ }\mu\text{A}$ | - | 1.1 | - | V |
| V_{OL} | LOW-level output voltage | A port; $V_{CC(A)} = 1.2\text{ V}$; $I_O = 20\text{ }\mu\text{A}$ | - | 0.09 | - | V |
| I_I | input leakage current | OE input; $V_I = 0\text{ V to }3.6\text{ V}$; $V_{CC(A)} = 1.2\text{ V to }3.6\text{ V}$; $V_{CC(B)} = 1.65\text{ V to }5.5\text{ V}$ | - | - | ± 1 | μA |
| I_{OZ} | OFF-state output current | A or B port; $V_O = 0\text{ V to }V_{CCO}$; $V_{CC(A)} = 1.2\text{ V to }3.6\text{ V}$; $V_{CC(B)} = 1.65\text{ V to }5.5\text{ V}$ | [1] | - | ± 1 | μA |
| I_{OFF} | power-off leakage current | A port; V_I or $V_O = 0\text{ V to }3.6\text{ V}$; $V_{CC(A)} = 0\text{ V}$; $V_{CC(B)} = 0\text{ V to }5.5\text{ V}$ | - | - | ± 1 | μA |
| | | B port; V_I or $V_O = 0\text{ V to }5.5\text{ V}$; $V_{CC(B)} = 0\text{ V}$; $V_{CC(A)} = 0\text{ V to }3.6\text{ V}$ | - | - | ± 1 | μA |
| I_{CC} | supply current | $V_I = 0\text{ V or }V_{CCI}$; $I_O = 0\text{ A}$ | [2] | | | |
| | | $I_{CC(A)}$; $V_{CC(A)} = 1.2\text{ V}$; $V_{CC(B)} = 1.65\text{ V to }5.5\text{ V}$ | - | 0.05 | - | μA |
| | | $I_{CC(B)}$; $V_{CC(A)} = 1.2\text{ V}$; $V_{CC(B)} = 1.65\text{ V to }5.5\text{ V}$ | - | 3.3 | - | μA |
| | | $I_{CC(A)} + I_{CC(B)}$; $V_{CC(A)} = 1.2\text{ V}$; $V_{CC(B)} = 1.65\text{ V to }5.5\text{ V}$ | - | 3.5 | - | μA |
| C_I | input capacitance | OE input; $V_{CC(A)} = 1.2\text{ V to }3.6\text{ V}$; $V_{CC(B)} = 1.65\text{ V to }5.5\text{ V}$ | - | 2.8 | - | pF |
| $C_{I/O}$ | input/output capacitance | A port; $V_{CC(A)} = 1.2\text{ V to }3.6\text{ V}$; $V_{CC(B)} = 1.65\text{ V to }5.5\text{ V}$ | - | 4.0 | - | pF |
| | | B port; $V_{CC(A)} = 1.2\text{ V to }3.6\text{ V}$; $V_{CC(B)} = 1.65\text{ V to }5.5\text{ V}$ | - | 7.5 | - | pF |

[1] V_{CCO} is the supply voltage associated with the output.

[2] V_{CCI} is the supply voltage associated with the input.

Table 8. Typical supply current

At recommended operating conditions; voltages are referenced to GND (ground = 0 V); $T_{amb} = 25\text{ }^{\circ}\text{C}$.

| $V_{CC(A)}$ | $V_{CC(B)}$ | | | | | | | | Unit |
|-------------|-------------|-------------|-------------|-------------|-------------|-------------|-------------|-------------|------|
| | 1.8 V | | 2.5 V | | 3.3 V | | 5.0 V | | |
| | $I_{CC(A)}$ | $I_{CC(B)}$ | $I_{CC(A)}$ | $I_{CC(B)}$ | $I_{CC(A)}$ | $I_{CC(B)}$ | $I_{CC(A)}$ | $I_{CC(B)}$ | |
| 1.2 V | 10 | 10 | 10 | 10 | 10 | 20 | 10 | 1050 | nA |
| 1.5 V | 10 | 10 | 10 | 10 | 10 | 10 | 10 | 650 | nA |
| 1.8 V | 10 | 10 | 10 | 10 | 10 | 10 | 10 | 350 | nA |
| 2.5 V | - | - | 10 | 10 | 10 | 10 | 10 | 40 | nA |
| 3.3 V | - | - | - | - | 10 | 10 | 10 | 10 | nA |

Table 9. Static characteristics

At recommended operating conditions; voltages are referenced to GND (ground = 0 V).

| Symbol | Parameter | Conditions | -40 °C to +85 °C | | -40 °C to +125 °C | | Unit |
|------------------|---------------------------|---|------------------------|----------------------|------------------------|----------------------|------|
| | | | Min | Max | Min | Max | |
| V _{IH} | HIGH-level input voltage | A or B port and OE input [1] | | | | | |
| | | V _{CC(A)} = 1.2 V to 3.6 V; V _{CC(B)} = 1.65 V to 5.5 V | 0.65V _{CCI} | - | 0.65V _{CCI} | - | V |
| V _{IL} | LOW-level input voltage | A or B port and OE input [1] | | | | | |
| | | V _{CC(A)} = 1.2 V to 3.6 V; V _{CC(B)} = 1.65 V to 5.5 V | - | 0.35V _{CCI} | - | 0.35V _{CCI} | V |
| V _{OH} | HIGH-level output voltage | A or B port; I _O = -20 μA [2] | | | | | |
| | | A port; V _{CC(A)} = 1.4 V to 3.6 V | V _{CCO} - 0.4 | - | V _{CCO} - 0.4 | - | V |
| | | B port; V _{CC(B)} = 1.65 V to 5.5 V | V _{CCO} - 0.4 | - | V _{CCO} - 0.4 | - | V |
| V _{OL} | LOW-level output voltage | A or B port; I _O = 20 μA [2] | | | | | |
| | | A port; V _{CC(A)} = 1.4 V to 3.6 V | - | 0.4 | - | 0.4 | V |
| | | B port; V _{CC(B)} = 1.65 V to 5.5 V | - | 0.4 | - | 0.4 | V |
| I _I | input leakage current | OE input; V _I = 0 V to 3.6 V; V _{CC(A)} = 1.2 V to 3.6 V; V _{CC(B)} = 1.65 V to 5.5 V | - | ±2 | - | ±5 | μA |
| I _{OZ} | OFF-state output current | A or B port; V _O = 0 V or V _{CCO} ; V _{CC(A)} = 1.2 V to 3.6 V; V _{CC(B)} = 1.65 V to 5.5 V [2] | - | ±2 | - | ±10 | μA |
| I _{OFF} | power-off leakage current | A port; V _I or V _O = 0 V to 3.6 V; V _{CC(A)} = 0 V; V _{CC(B)} = 0 V to 5.5 V | - | ±2 | - | ±10 | μA |
| | | B port; V _I or V _O = 0 V to 5.5 V; V _{CC(B)} = 0 V; V _{CC(A)} = 0 V to 3.6 V | - | ±2 | - | ±10 | μA |

Table 9. Static characteristics ...continued

At recommended operating conditions; voltages are referenced to GND (ground = 0 V).

| Symbol | Parameter | Conditions | -40 °C to +85 °C | | -40 °C to +125 °C | | Unit | |
|--|----------------|--|------------------|-----|-------------------|-----|------|----|
| | | | Min | Max | Min | Max | | |
| I _{CC} | supply current | V _I = 0 V or V _{CC(I)} ; I _O = 0 A [1] | | | | | | |
| | | I _{CC(A)} | | | | | | |
| | | OE = LOW; V _{CC(A)} = 1.4 V to 3.6 V; V _{CC(B)} = 1.65 V to 5.5 V | | - | 5 | - | 15 | μA |
| | | OE = HIGH; V _{CC(A)} = 1.4 V to 3.6 V; V _{CC(B)} = 1.65 V to 5.5 V | | - | 5 | - | 20 | μA |
| | | V _{CC(A)} = 3.6 V; V _{CC(B)} = 0 V | | - | 2 | - | 15 | μA |
| | | V _{CC(A)} = 0 V; V _{CC(B)} = 5.5 V | | - | -2 | - | -15 | μA |
| | | I _{CC(B)} | | | | | | |
| | | OE = LOW; V _{CC(A)} = 1.4 V to 3.6 V; V _{CC(B)} = 1.65 V to 5.5 V | | - | 5 | - | 15 | μA |
| | | OE = HIGH; V _{CC(A)} = 1.4 V to 3.6 V; V _{CC(B)} = 1.65 V to 5.5 V | | - | 5 | - | 20 | μA |
| | | V _{CC(A)} = 3.6 V; V _{CC(B)} = 0 V | | - | -2 | - | -15 | μA |
| | | V _{CC(A)} = 0 V; V _{CC(B)} = 5.5 V | | - | 2 | - | 15 | μA |
| | | I _{CC(A)} + I _{CC(B)} | | | | | | |
| V _{CC(A)} = 1.4 V to 3.6 V; V _{CC(B)} = 1.65 V to 5.5 V | | - | 10 | - | 40 | μA | | |

[1] V_{CC(I)} is the supply voltage associated with the input.

[2] V_{CC(O)} is the supply voltage associated with the output.

10. Dynamic characteristics

Table 10. Typical dynamic characteristics for temperature 25 °C[\[1\]](#)

Voltages are referenced to GND (ground = 0 V); for test circuit see [Figure 8](#); for waveforms see [Figure 6](#) and [Figure 7](#).

| Symbol | Parameter | Conditions | V _{CC(B)} | | | | Unit |
|---|-------------------|---|--------------------|-------|-------|-------|------|
| | | | 1.8 V | 2.5 V | 3.3 V | 5.0 V | |
| V_{CC(A)} = 1.2 V; T_{amb} = 25 °C | | | | | | | |
| t _{pd} | propagation delay | A to B | 5.9 | 4.8 | 4.4 | 4.2 | ns |
| | | B to A | 5.6 | 4.8 | 4.5 | 4.4 | ns |
| t _{en} | enable time | OE to A, B | 0.5 | 0.5 | 0.5 | 0.5 | μs |
| t _{dis} | disable time | OE to A; no external load [2] | 8.3 | 8.3 | 8.3 | 8.3 | ns |
| | | OE to B; no external load [2] | 10.4 | 9.4 | 9.3 | 8.8 | ns |
| | | OE to A | 81 | 69 | 83 | 68 | ns |
| | | OE to B | 81 | 69 | 83 | 68 | ns |
| t _t | transition time | A port | 4.0 | 4.0 | 4.1 | 4.1 | ns |
| | | B port | 2.6 | 2.0 | 1.7 | 1.4 | ns |

Table 10. Typical dynamic characteristics for temperature 25 °C [\[1\]](#) ...continued

Voltages are referenced to GND (ground = 0 V); for test circuit see [Figure 8](#); for waveforms see [Figure 6](#) and [Figure 7](#).

| Symbol | Parameter | Conditions | V _{CC(B)} | | | | Unit | |
|--------------------|------------------|------------------|---------------------|-------|-------|-------|------|------|
| | | | 1.8 V | 2.5 V | 3.3 V | 5.0 V | | |
| t _{sk(o)} | output skew time | between channels | [3] | 0.2 | 0.2 | 0.2 | 0.2 | ns |
| t _W | pulse width | data inputs | | 15 | 13 | 13 | 13 | ns |
| f _{data} | data rate | | | 70 | 80 | 80 | 80 | Mbps |

- [1] t_{pd} is the same as t_{PLH} and t_{PHL}.
t_{en} is the same as t_{PZL} and t_{PZH}.
t_{dis} is the same as t_{PLZ} and t_{PHZ}.
t_i is the same as t_{THL} and t_{TLH}.

[2] Delay between OE going LOW and when the outputs are actually disabled.

[3] Skew between any two outputs of the same package switching in the same direction.

Table 11. Dynamic characteristics for temperature range -40 °C to +85 °C [\[1\]](#)

Voltages are referenced to GND (ground = 0 V); for test circuit see [Figure 8](#); for wave forms see [Figure 6](#) and [Figure 7](#).

| Symbol | Parameter | Conditions | V _{CC(B)} | | | | | | | | Unit | |
|---|-------------------|---------------------------|---------------------|------|---------------|------|---------------|------|---------------|------|------|------|
| | | | 1.8 V ± 0.15 V | | 2.5 V ± 0.2 V | | 3.3 V ± 0.3 V | | 5.0 V ± 0.5 V | | | |
| | | | Min | Max | Min | Max | Min | Max | Min | Max | | |
| V_{CC(A)} = 1.5 V ± 0.1 V | | | | | | | | | | | | |
| t _{pd} | propagation delay | A to B | 1.4 | 12.9 | 1.2 | 10.1 | 1.1 | 10.0 | 0.8 | 9.9 | ns | |
| | | B to A | 0.9 | 14.2 | 0.7 | 12.0 | 0.4 | 11.7 | 0.3 | 13.7 | ns | |
| t _{en} | enable time | OE to A, B | - | 1.0 | - | 1.0 | - | 1.0 | - | 1.0 | µs | |
| t _{dis} | disable time | OE to A; no external load | [2] | 1.0 | 12.9 | 1.0 | 12.9 | 1.0 | 12.9 | 1.0 | 12.9 | ns |
| | | OE to B; no external load | [2] | 1.0 | 18.7 | 1.0 | 15.8 | 1.0 | 15.1 | 1.0 | 14.4 | ns |
| | | OE to A | | - | 320 | - | 260 | - | 260 | - | 280 | ns |
| | | OE to B | | - | 200 | - | 200 | - | 200 | - | 200 | ns |
| t _i | transition time | A port | 0.9 | 5.1 | 0.9 | 5.1 | 0.9 | 5.1 | 0.9 | 5.1 | ns | |
| | | B port | 0.9 | 4.7 | 0.6 | 3.2 | 0.5 | 2.5 | 0.4 | 2.7 | ns | |
| t _{sk(o)} | output skew time | between channels | [3] | - | 0.5 | - | 0.5 | - | 0.5 | - | 0.5 | ns |
| t _W | pulse width | data inputs | | 25 | - | 25 | - | 25 | - | 25 | - | ns |
| f _{data} | data rate | | | - | 40 | - | 40 | - | 40 | - | 40 | Mbps |
| V_{CC(A)} = 1.8 V ± 0.15 V | | | | | | | | | | | | |
| t _{pd} | propagation delay | A to B | 1.6 | 11.0 | 1.4 | 7.7 | 1.3 | 6.8 | 1.2 | 6.5 | ns | |
| | | B to A | 1.5 | 12.0 | 1.3 | 8.4 | 1.0 | 7.6 | 0.9 | 7.1 | ns | |
| t _{en} | enable time | OE to A, B | - | 1.0 | - | 1.0 | - | 1.0 | - | 1.0 | µs | |
| t _{dis} | disable time | OE to A; no external load | [2] | 1.0 | 11.7 | 1.0 | 11.7 | 1.0 | 11.7 | 1.0 | 11.7 | ns |
| | | OE to B; no external load | [2] | 1.0 | 16.9 | 1.0 | 14.5 | 1.0 | 13.7 | 1.0 | 12.7 | ns |
| | | OE to A | | - | 260 | - | 230 | - | 230 | - | 230 | ns |
| | | OE to B | | - | 200 | - | 200 | - | 200 | - | 200 | ns |
| t _i | transition time | A port | 0.8 | 4.1 | 0.8 | 4.1 | 0.8 | 4.1 | 0.8 | 4.1 | ns | |
| | | B port | 0.9 | 4.7 | 0.6 | 3.2 | 0.5 | 2.5 | 0.4 | 2.7 | ns | |

Table 11. Dynamic characteristics for temperature range -40 °C to +85 °C ^[1] ...continued

Voltages are referenced to GND (ground = 0 V); for test circuit see [Figure 8](#); for wave forms see [Figure 6](#) and [Figure 7](#).

| Symbol | Parameter | Conditions | | V _{CC(B)} | | | | | | | | Unit |
|--|-------------------|---------------------------|----------------|--------------------|-----|---------------|------|---------------|------|---------------|------|------|
| | | | | 1.8 V ± 0.15 V | | 2.5 V ± 0.2 V | | 3.3 V ± 0.3 V | | 5.0 V ± 0.5 V | | |
| | | | | Min | Max | Min | Max | Min | Max | Min | Max | |
| t _{sk(o)} | output skew time | between channels | ^[3] | - | 0.5 | - | 0.5 | - | 0.5 | - | 0.5 | ns |
| t _W | pulse width | data inputs | | 20 | - | 17 | - | 17 | - | 17 | - | ns |
| f _{data} | data rate | | | - | 49 | - | 60 | - | 60 | - | 60 | Mbps |
| V_{CC(A)} = 2.5 V ± 0.2 V | | | | | | | | | | | | |
| t _{pd} | propagation delay | A to B | | - | - | 1.1 | 6.3 | 1.0 | 5.2 | 0.9 | 4.7 | ns |
| | | B to A | | - | - | 1.2 | 6.6 | 1.1 | 5.1 | 0.9 | 4.4 | ns |
| t _{en} | enable time | OE to A, B | | - | - | - | 1.0 | - | 1.0 | - | 1.0 | µs |
| t _{dis} | disable time | OE to A; no external load | ^[2] | - | - | 1.0 | 9.7 | 1.0 | 9.7 | 1.0 | 9.7 | ns |
| | | OE to B; no external load | ^[2] | - | - | 1.0 | 12.9 | 1.0 | 12.0 | 1.0 | 11.0 | ns |
| | | OE to A | | - | - | - | 200 | - | 200 | - | 200 | ns |
| | | OE to B | | - | - | - | 200 | - | 200 | - | 200 | ns |
| t _t | transition time | A port | | - | - | 0.7 | 3.0 | 0.7 | 3.0 | 0.7 | 3.0 | ns |
| | | B port | | - | - | 0.7 | 3.2 | 0.5 | 2.5 | 0.4 | 2.7 | ns |
| t _{sk(o)} | output skew time | between channels | ^[3] | - | - | - | 0.5 | - | 0.5 | - | 0.5 | ns |
| t _W | pulse width | data inputs | | - | - | 12 | - | 10 | - | 10 | - | ns |
| f _{data} | data rate | | | - | - | - | 85 | - | 100 | - | 100 | Mbps |
| V_{CC(A)} = 3.3 V ± 0.3 V | | | | | | | | | | | | |
| t _{pd} | propagation delay | A to B | | - | - | - | - | 0.9 | 4.7 | 0.8 | 4.0 | ns |
| | | B to A | | - | - | - | - | 1.0 | 4.9 | 0.9 | 3.8 | ns |
| t _{en} | enable time | OE to A, B | | - | - | - | - | - | 1.0 | - | 1.0 | µs |
| t _{dis} | disable time | OE to A; no external load | ^[2] | - | - | - | - | 1.0 | 9.4 | 1.0 | 9.4 | ns |
| | | OE to B; no external load | ^[2] | - | - | - | - | 1.0 | 11.3 | 1.0 | 10.4 | ns |
| | | OE to A | | - | - | - | - | - | 260 | - | 260 | ns |
| | | OE to B | | - | - | - | - | - | 200 | - | 200 | ns |
| t _t | transition time | A port | | - | - | - | - | 0.7 | 2.5 | 0.7 | 2.5 | ns |
| | | B port | | - | - | - | - | 0.5 | 2.5 | 0.4 | 2.7 | ns |
| t _{sk(o)} | output skew time | between channels | ^[3] | - | - | - | - | - | 0.5 | - | 0.5 | ns |
| t _W | pulse width | data inputs | | - | - | - | - | 10 | - | 10 | - | ns |
| f _{data} | data rate | | | - | - | - | - | - | 100 | - | 100 | Mbps |

[1] t_{pd} is the same as t_{PLH} and t_{PHL}.
t_{en} is the same as t_{PZL} and t_{PZH}.
t_{dis} is the same as t_{PLZ} and t_{PHZ}.
t_t is the same as t_{THL} and t_{TLH}

[2] Delay between OE going LOW and when the outputs are actually disabled.

[3] Skew between any two outputs of the same package switching in the same direction.

Table 12. Dynamic characteristics for temperature range -40 °C to +125 °C

Voltages are referenced to GND (ground = 0 V); for test circuit see [Figure 8](#); for wave forms see [Figure 6](#) and [Figure 7](#).

| Symbol | Parameter | Conditions | V _{CC(B)} | | | | | | | | Unit | |
|---|-------------------|---------------------------|--------------------|------|---------------|------|---------------|------|---------------|------|------|--|
| | | | 1.8 V ± 0.15 V | | 2.5 V ± 0.2 V | | 3.3 V ± 0.3 V | | 5.0 V ± 0.5 V | | | |
| | | | Min | Max | Min | Max | Min | Max | Min | Max | | |
| V_{CC(A)} = 1.5 V ± 0.1 V | | | | | | | | | | | | |
| t _{pd} | propagation delay | A to B | 1.4 | 15.9 | 1.2 | 13.1 | 1.1 | 13.0 | 0.8 | 12.9 | ns | |
| | | B to A | 0.9 | 17.2 | 0.7 | 15.0 | 0.4 | 14.7 | 0.3 | 16.7 | ns | |
| t _{en} | enable time | OE to A, B | - | 1.0 | - | 1.0 | - | 1.0 | - | 1.0 | µs | |
| t _{dis} | disable time | OE to A; no external load | 1.0 | 13.5 | 1.0 | 13.5 | 1.0 | 13.5 | 1.0 | 13.5 | ns | |
| | | OE to B; no external load | 1.0 | 19.9 | 1.0 | 16.8 | 1.0 | 16.1 | 1.0 | 15.2 | ns | |
| | | OE to A | - | 340 | - | 280 | - | 280 | - | 300 | ns | |
| | | OE to B | - | 220 | - | 220 | - | 220 | - | 220 | ns | |
| t _t | transition time | A port | 0.9 | 7.1 | 0.9 | 7.1 | 0.9 | 7.1 | 0.9 | 7.1 | ns | |
| | | B port | 0.9 | 6.5 | 0.6 | 5.2 | 0.5 | 4.8 | 0.4 | 4.7 | ns | |
| t _{sk(o)} | output skew time | between channels | - | 0.5 | - | 0.5 | - | 0.5 | - | 0.5 | ns | |
| t _w | pulse width | data inputs | 25 | - | 25 | - | 25 | - | 25 | - | ns | |
| f _{data} | data rate | | - | 40 | - | 40 | - | 40 | - | 40 | Mbps | |
| V_{CC(A)} = 1.8 V ± 0.15 V | | | | | | | | | | | | |
| t _{pd} | propagation delay | A to B | 1.6 | 14.0 | 1.4 | 10.7 | 1.3 | 9.8 | 1.2 | 9.5 | ns | |
| | | B to A | 1.5 | 15.0 | 1.3 | 11.4 | 1.0 | 10.6 | 0.9 | 10.1 | ns | |
| t _{en} | enable time | OE to A, B | - | 1.0 | - | 1.0 | - | 1.0 | - | 1.0 | µs | |
| t _{dis} | disable time | OE to A; no external load | 1.0 | 12.3 | 1.0 | 12.3 | 1.0 | 12.3 | 1.0 | 12.3 | ns | |
| | | OE to B; no external load | 1.0 | 18.1 | 1.0 | 15.3 | 1.0 | 14.5 | 1.0 | 13.5 | ns | |
| | | OE to A | - | 280 | - | 250 | - | 250 | - | 250 | ns | |
| | | OE to B | - | 220 | - | 220 | - | 220 | - | 220 | ns | |
| t _t | transition time | A port | 0.8 | 6.2 | 0.8 | 6.1 | 0.8 | 6.1 | 0.8 | 6.1 | ns | |
| | | B port | 0.9 | 5.8 | 0.6 | 5.2 | 0.5 | 4.8 | 0.4 | 4.7 | ns | |
| t _{sk(o)} | output skew time | between channels | - | 0.5 | - | 0.5 | - | 0.5 | - | 0.5 | ns | |
| t _w | pulse width | data inputs | 22 | - | 19 | - | 19 | - | 19 | - | ns | |
| f _{data} | data rate | | - | 45 | - | 55 | - | 55 | - | 55 | Mbps | |
| V_{CC(A)} = 2.5 V ± 0.2 V | | | | | | | | | | | | |
| t _{pd} | propagation delay | A to B | - | - | 1.1 | 9.3 | 1.0 | 8.2 | 0.9 | 7.7 | ns | |
| | | B to A | - | - | 1.2 | 9.6 | 1.1 | 8.1 | 0.9 | 7.4 | ns | |
| t _{en} | enable time | OE to A, B | - | - | - | 1.0 | - | 1.0 | - | 1.0 | µs | |
| t _{dis} | disable time | OE to A; no external load | - | - | 1.0 | 10.1 | 1.0 | 10.1 | 1.0 | 10.1 | ns | |
| | | OE to B; no external load | - | - | 1.0 | 13.5 | 1.0 | 12.7 | 1.0 | 11.7 | ns | |
| | | OE to A | - | - | - | 220 | - | 220 | - | 220 | ns | |
| | | OE to B | - | - | - | 220 | - | 220 | - | 220 | ns | |
| t _t | transition time | A port | - | - | 0.7 | 5.0 | 0.7 | 5.0 | 0.7 | 5.0 | ns | |
| | | B port | - | - | 0.7 | 4.6 | 0.5 | 4.8 | 0.4 | 4.7 | ns | |

Table 12. Dynamic characteristics for temperature range $-40\text{ }^{\circ}\text{C}$ to $+125\text{ }^{\circ}\text{C}$ [1]

Voltages are referenced to GND (ground = 0 V); for test circuit see [Figure 8](#); for wave forms see [Figure 6](#) and [Figure 7](#).

| Symbol | Parameter | Conditions | $V_{CC(B)}$ | | | | | | | | Unit | |
|---|-------------------|---------------------------|----------------------------------|-----|---------------------------------|-----|---------------------------------|-----|---------------------------------|-----|------|---------------|
| | | | $1.8\text{ V} \pm 0.15\text{ V}$ | | $2.5\text{ V} \pm 0.2\text{ V}$ | | $3.3\text{ V} \pm 0.3\text{ V}$ | | $5.0\text{ V} \pm 0.5\text{ V}$ | | | |
| | | | Min | Max | Min | Max | Min | Max | Min | Max | | |
| $t_{sk(o)}$ | output skew time | between channels | [3] | - | - | - | 0.5 | - | 0.5 | - | 0.5 | ns |
| t_W | pulse width | data inputs; | | - | - | 14 | - | 13 | - | 10 | - | ns |
| f_{data} | data rate | | | - | - | - | 75 | - | 80 | - | 100 | Mbps |
| $V_{CC(A)} = 3.3\text{ V} \pm 0.3\text{ V}$ | | | | | | | | | | | | |
| t_{pd} | propagation delay | A to B | | - | - | - | - | 0.9 | 7.7 | 0.8 | 7.0 | ns |
| | | B to A | | - | - | - | - | 1.0 | 7.9 | 0.9 | 6.8 | ns |
| t_{en} | enable time | OE to A, B | | - | - | - | - | - | 1.0 | - | 1.0 | μs |
| t_{dis} | disable time | OE to A; no external load | [2] | - | - | - | - | 1.0 | 9.9 | 1.0 | 9.9 | ns |
| | | OE to B; no external load | [2] | - | - | - | - | 1.0 | 12.1 | 1.0 | 10.9 | ns |
| | | OE to A | | - | - | - | - | - | 280 | - | 280 | ns |
| | | OE to B | | - | - | - | - | - | 220 | - | 220 | ns |
| t_t | transition time | A port | | - | - | - | - | 0.7 | 4.5 | 0.7 | 4.5 | ns |
| | | B port | | - | - | - | - | 0.5 | 4.1 | 0.4 | 4.7 | ns |
| $t_{sk(o)}$ | output skew time | between channels | [3] | - | - | - | - | - | 0.5 | - | 0.5 | ns |
| t_W | pulse width | data inputs | | - | - | - | - | 10 | - | 10 | - | ns |
| f_{data} | data rate | | | - | - | - | - | - | 100 | - | 100 | Mbps |

[1] t_{pd} is the same as t_{PLH} and t_{PHL} .
 t_{en} is the same as t_{PZL} and t_{PZH} .
 t_{dis} is the same as t_{PLZ} and t_{PHZ} .
 t_t is the same as t_{THL} and t_{TLH} .

[2] Delay between OE going LOW and when the outputs are actually disabled.

[3] Skew between any two outputs of the same package switching in the same direction.

Table 13. Typical power dissipation capacitance

Voltages are referenced to GND (ground = 0 V).^{[1][2]}

| Symbol | Parameter | Conditions | V _{CC(A)} | | | | | | | | Unit | |
|--------------------------------|-------------------------------|--|--------------------|-------|-------|-------|-------|-------|----------------|------|------|--|
| | | | 1.2 V | 1.2 V | 1.5 V | 1.8 V | 2.5 V | 2.5 V | 3.3 V | | | |
| | | | V _{CC(B)} | | | | | | | | | |
| | | | 1.8 V | 5.0 V | 1.8 V | 1.8 V | 2.5 V | 5.0 V | 3.3 V to 5.0 V | | | |
| T_{amb} = 25 °C | | | | | | | | | | | | |
| C _{PD} | power dissipation capacitance | outputs enabled; OE = V _{CC(A)} | | | | | | | | | | |
| | | A port: (direction A to B) | 5 | 5 | 5 | 5 | 5 | 5 | 5 | 5 | pF | |
| | | A port: (direction B to A) | 8 | 8 | 8 | 8 | 8 | 8 | 8 | 8 | pF | |
| | | B port: (direction A to B) | 18 | 18 | 18 | 18 | 18 | 18 | 18 | 18 | pF | |
| | | B port: (direction B to A) | 13 | 16 | 12 | 12 | 12 | 12 | 13 | 13 | pF | |
| | | outputs disabled; OE = GND | | | | | | | | | | |
| | | A port: (direction A to B) | 0.12 | 0.12 | 0.04 | 0.05 | 0.08 | 0.08 | 0.07 | 0.07 | pF | |
| | | A port: (direction B to A) | 0.01 | 0.01 | 0.01 | 0.01 | 0.01 | 0.01 | 0.01 | 0.01 | pF | |
| | | B port: (direction A to B) | 0.01 | 0.01 | 0.01 | 0.01 | 0.01 | 0.01 | 0.01 | 0.01 | pF | |
| B port: (direction B to A) | 0.07 | 0.09 | 0.07 | 0.07 | 0.05 | 0.09 | 0.09 | 0.09 | pF | | | |

[1] C_{PD} is used to determine the dynamic power dissipation (P_D in μW).

$$P_D = C_{PD} \times V_{CC}^2 \times f_i \times N + \sum(C_L \times V_{CC}^2 \times f_o) \text{ where:}$$

f_i = input frequency in MHz;

f_o = output frequency in MHz;

C_L = load capacitance in pF;

V_{CC} = supply voltage in V;

N = number of inputs switching;

∑(C_L × V_{CC}² × f_o) = sum of the outputs.

[2] f_i = 10 MHz; V_I = GND to V_{CC}; t_r = t_f = 1 ns; C_L = 0 pF; R_L = ∞ Ω.

11. Waveforms

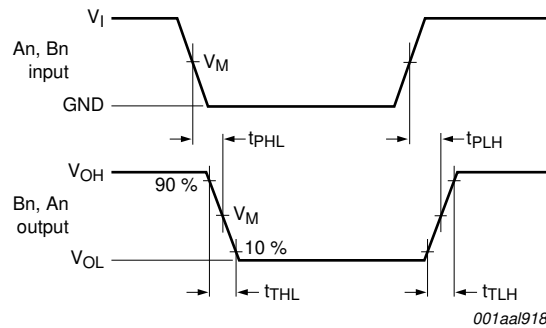

Measurement points are given in [Table 14](#).

V_{OL} and V_{OH} are typical output voltage levels that occur with the output load.

Fig 6. The data input (An, Bn) to data output (Bn, An) propagation delay times

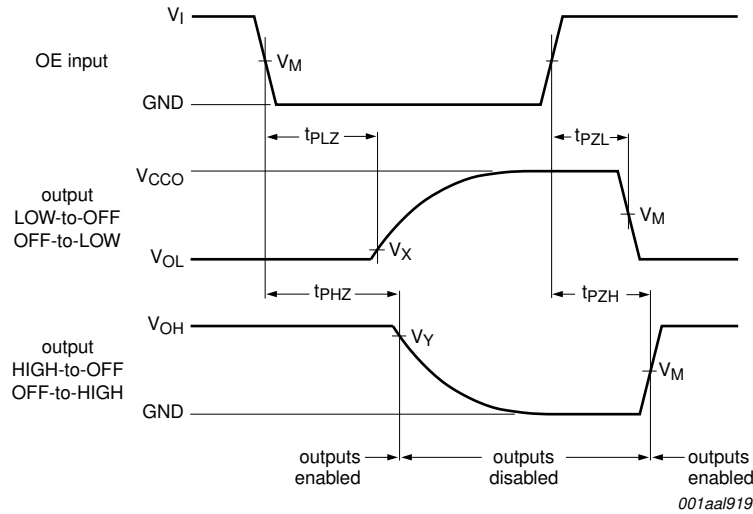

Measurement points are given in [Table 14](#).

V_{OL} and V_{OH} are typical output voltage levels that occur with the output load.

Fig 7. Enable and disable times

Table 14. Measurement points^[1]

| Supply voltage | Input | Output | | |
|--------------------|--------------|--------------|-------------------|-------------------|
| V_{CCO} | V_M | V_M | V_X | V_Y |
| 1.2 V | $0.5V_{CCI}$ | $0.5V_{CCO}$ | $V_{OL} + 0.1 V$ | $V_{OH} - 0.1 V$ |
| $1.5 V \pm 0.1 V$ | $0.5V_{CCI}$ | $0.5V_{CCO}$ | $V_{OL} + 0.1 V$ | $V_{OH} - 0.1 V$ |
| $1.8 V \pm 0.15 V$ | $0.5V_{CCI}$ | $0.5V_{CCO}$ | $V_{OL} + 0.15 V$ | $V_{OH} - 0.15 V$ |
| $2.5 V \pm 0.2 V$ | $0.5V_{CCI}$ | $0.5V_{CCO}$ | $V_{OL} + 0.15 V$ | $V_{OH} - 0.15 V$ |
| $3.3 V \pm 0.3 V$ | $0.5V_{CCI}$ | $0.5V_{CCO}$ | $V_{OL} + 0.3 V$ | $V_{OH} - 0.3 V$ |
| $5.0 V \pm 0.5 V$ | $0.5V_{CCI}$ | $0.5V_{CCO}$ | $V_{OL} + 0.3 V$ | $V_{OH} - 0.3 V$ |

[1] V_{CCI} is the supply voltage associated with the input and V_{CCO} is the supply voltage associated with the output.

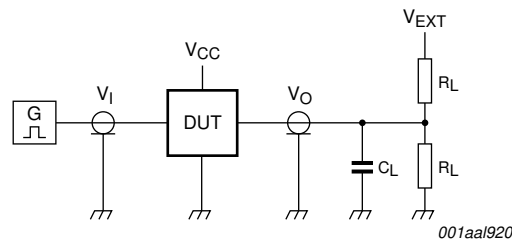
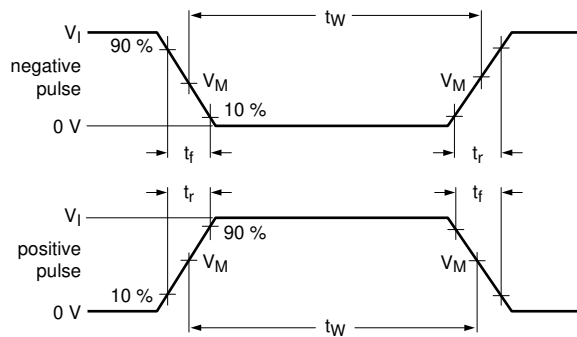

Test data is given in [Table 15](#).

All input pulses are supplied by generators having the following characteristics: PRR ≤ 10 MHz; Z_O = 50 Ω; dV/dt ≥ 1.0 V/ns.

R_L = Load resistance.

C_L = Load capacitance including jig and probe capacitance.

V_{EXT} = External voltage for measuring switching times.

Fig 8. Test circuit for measuring switching times

Table 15. Test data

| Supply voltage | | Input | | Load | | V _{EXT} | | |
|--------------------|--------------------|-------------------------------|------------|----------------|-------------------------------|-------------------------------------|-------------------------------------|--|
| V _{CC(A)} | V _{CC(B)} | V _I ^[1] | Δt/ΔV | C _L | R _L ^[2] | t _{PLH} , t _{PHL} | t _{PZH} , t _{PHZ} | t _{PZL} , t _{PLZ} ^[3] |
| 1.2 V to 3.6 V | 1.65 V to 5.5 V | V _{CCI} | ≤ 1.0 ns/V | 15 pF | 50 kΩ, 1 MΩ | open | open | 2V _{CCO} |

[1] V_{CCI} is the supply voltage associated with the input.

[2] For measuring data rate, pulse width, propagation delay and output rise and fall measurements, R_L = 1 MΩ; for measuring enable and disable times, R_L = 50 kΩ.

[3] V_{CCO} is the supply voltage associated with the output.

12. Application information

12.1 Applications

Voltage level-translation applications. The NTB0104 can be used to interface between devices or systems operating at different supply voltages. See [Figure 9](#) for a typical operating circuit using the NTB0104.

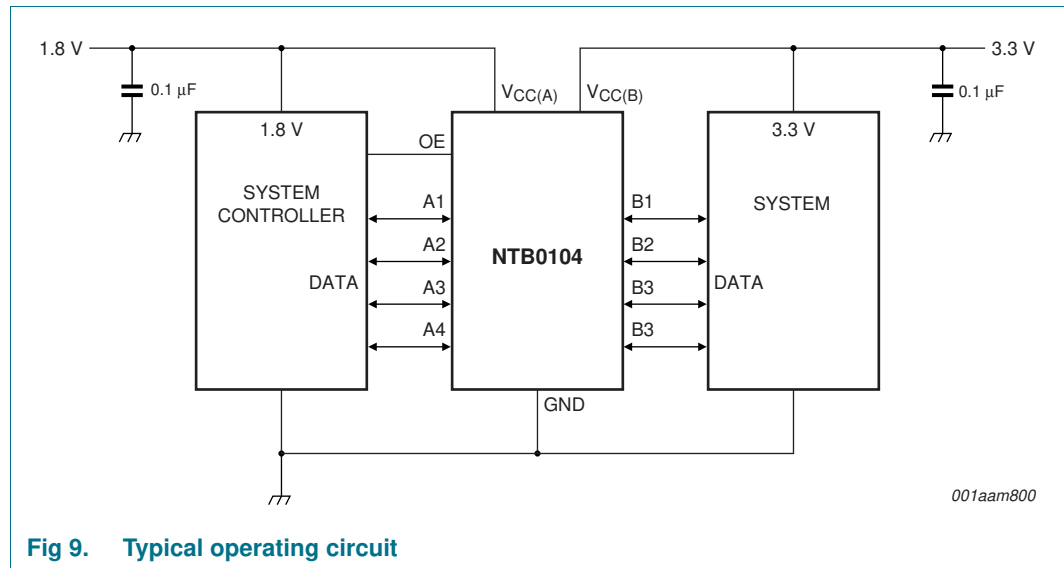

Fig 9. Typical operating circuit

12.2 Architecture

The architecture of the NTB0104 is shown in [Figure 10](#). The device does not require an extra input signal to control the direction of data flow from A to B or from B to A. In a static state, the output drivers of the NTB0104 can maintain a defined output level, but the output architecture is designed to be weak, so that they can be overdriven by an external driver when data on the bus starts flowing in the opposite direction. The output one shots detect rising or falling edges on the A or B ports. During a rising edge, the one shots turn on the PMOS transistors (T1, T3) for a short duration, accelerating the low-to-high transition. Similarly, during a falling edge, the one shots turn on the NMOS transistors (T2, T4) for a short duration, accelerating the high-to-low transition. During output transitions the typical output impedance is 70 Ω at V_{CCO} = 1.2 V to 1.8 V, 50 Ω at V_{CCO} = 1.8 V to 3.3 V and 40 Ω at V_{CCO} = 3.3 V to 5.0 V.

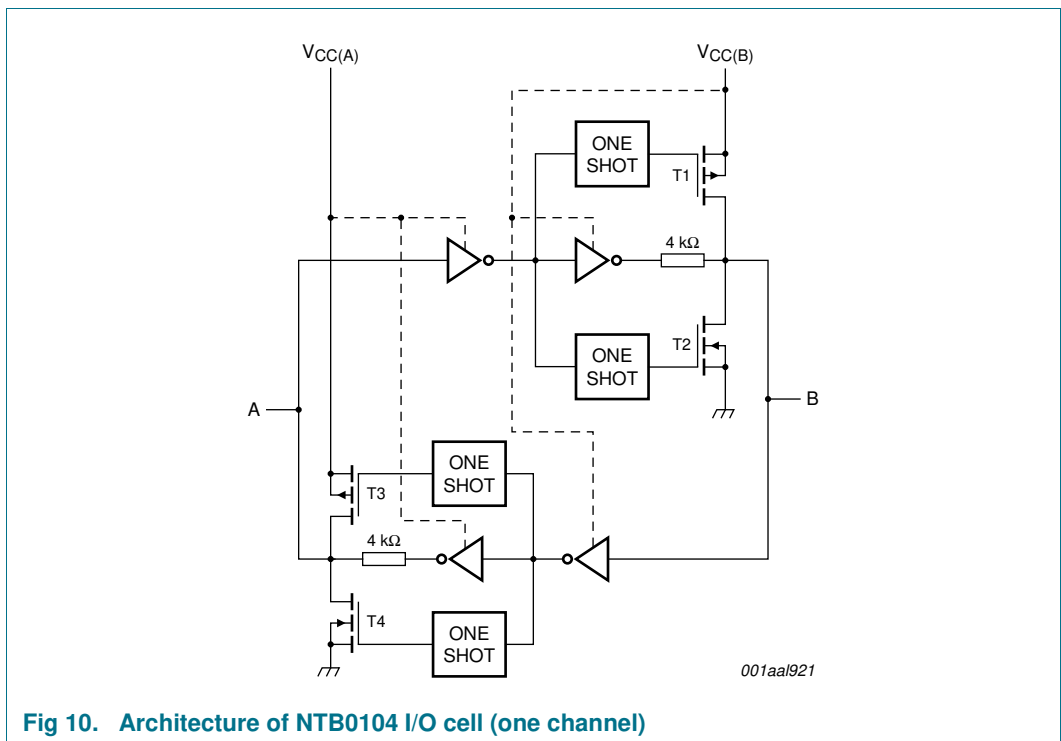
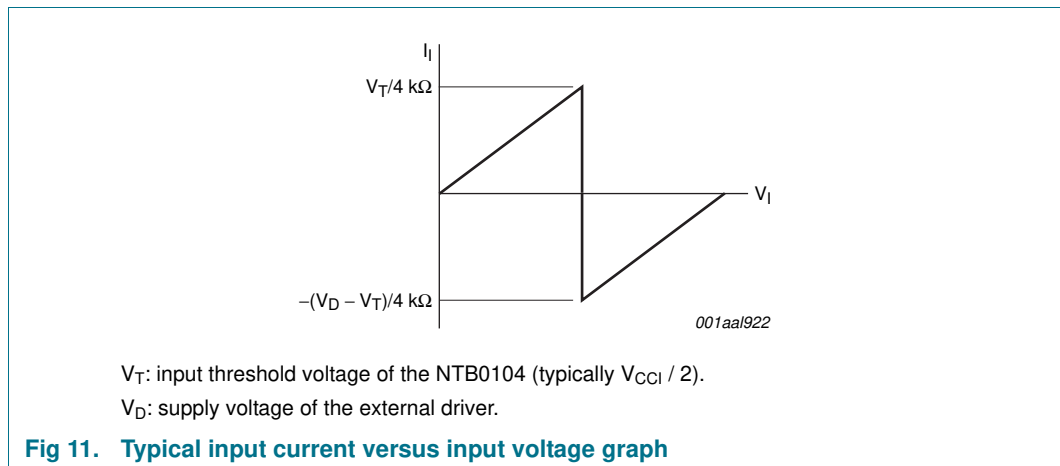

Fig 10. Architecture of NTB0104 I/O cell (one channel)

12.3 Input driver requirements

For correct operation, the device driving the data I/Os of the NTB0104 must have a minimum drive capability of ± 2 mA. See [Figure 11](#) for a plot of typical input current versus input voltage.



12.4 Power up

During operation $V_{CC(A)}$ must never be higher than $V_{CC(B)}$, however during power-up $V_{CC(A)} \geq V_{CC(B)}$ does not damage the device, so either power supply can be ramped up first. There is no special power-up sequencing required. The NTB0104 includes circuitry that disables all output ports when either $V_{CC(A)}$ or $V_{CC(B)}$ is switched off.

12.5 Enable and disable

An output enable input (OE) is used to disable the device. Setting OE = LOW causes all I/Os to assume the high-impedance OFF-state. The disable time (t_{dis} with no external load) indicates the delay between when OE goes LOW and when outputs actually become disabled. The enable time (t_{en}) indicates the amount of time the user must allow for one one-shot circuitry to become operational after OE is taken HIGH. To ensure the high-impedance OFF-state during power-up or power-down, pin OE should be tied to GND through a pull-down resistor, the minimum value of the resistor is determined by the current-sourcing capability of the driver.

12.6 Pull-up or pull-down resistors on I/O lines

As mentioned previously the NTB0104 is designed with low static drive strength to drive capacitive loads of up to 70 pF. To avoid output contention issues, any pull-up or pull-down resistors used must be kept higher than 50 k Ω . For this reason the NTB0104 is not recommended for use in open drain driver applications such as 1-Wire or I²C. For these applications, the NTS0104 level translator is recommended.

13. Package outline

DHVQFN14: plastic dual in-line compatible thermal enhanced very thin quad flat package; no leads; 14 terminals; body 2.5 x 3 x 0.85 mm

SOT762-1

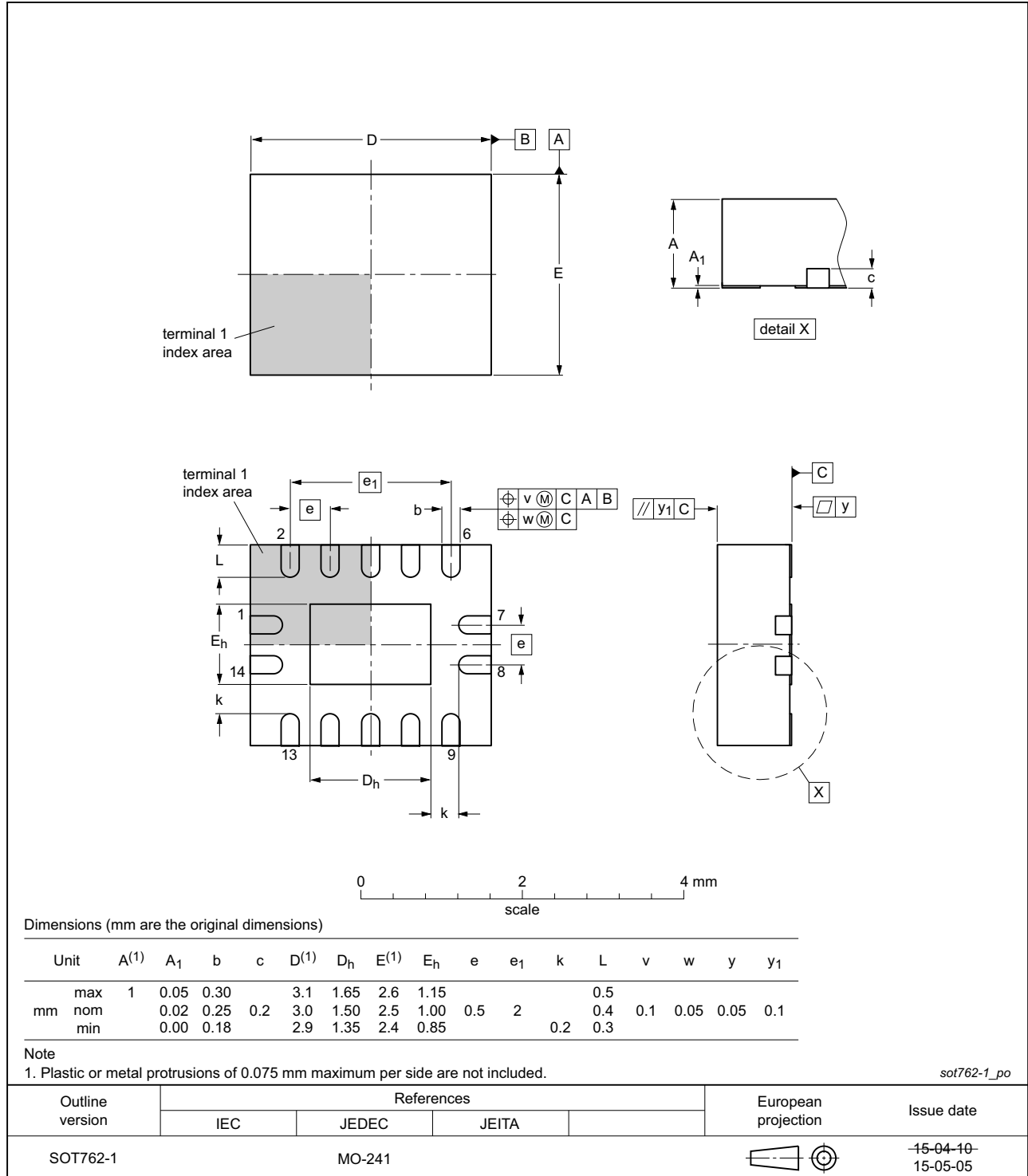

Fig 12. Package outline SOT762-1 (DHVQFN14)

XQFN12: plastic, extremely thin quad flat package; no leads;
12 terminals; body 1.70 x 2.00 x 0.50 mm

SOT1174-1

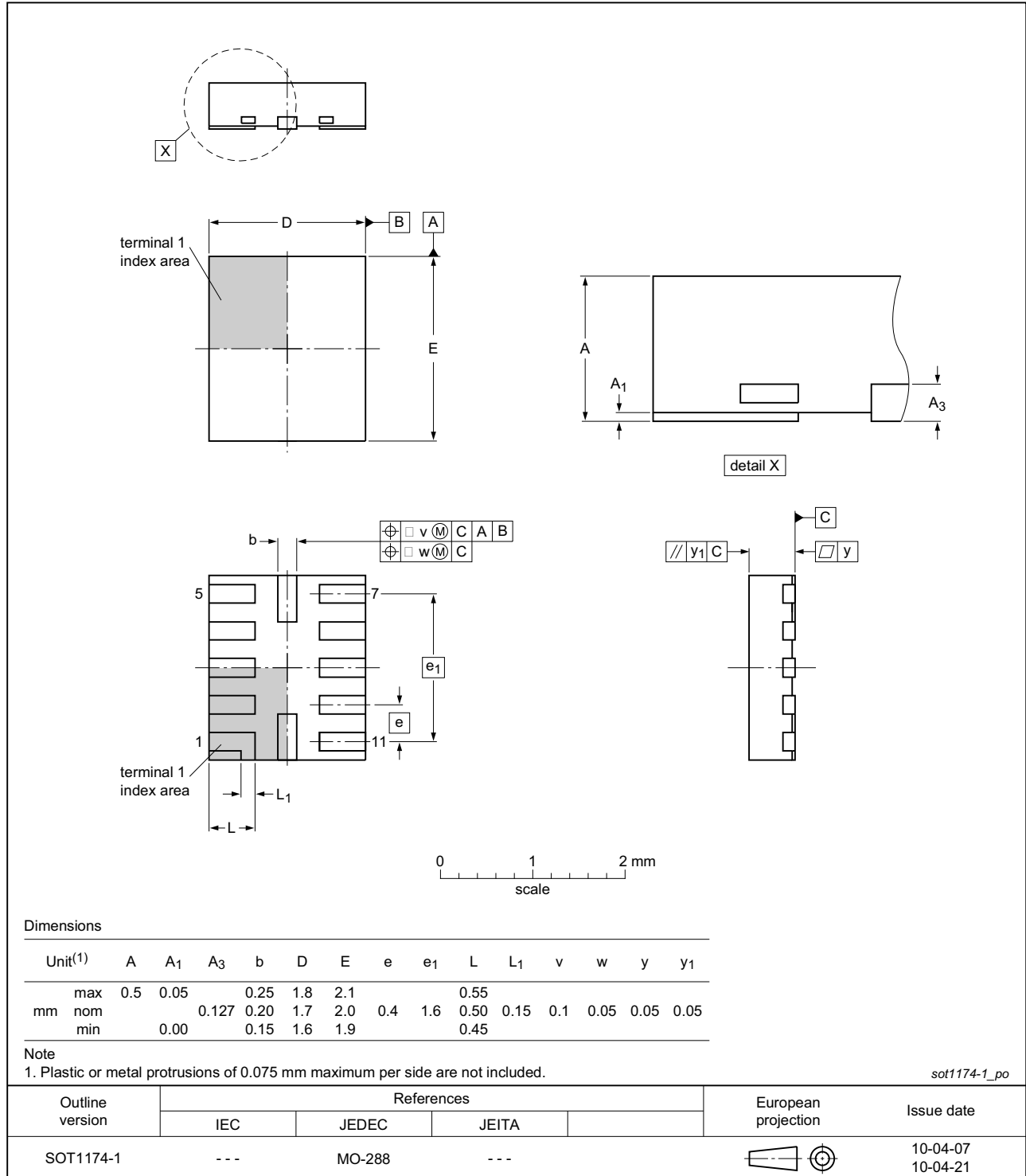

Fig 13. Package outline SOT1174-1 (XQFN12)

WLCSP12: wafer level chip-size package,
12 bumps; body 1.20 x 1.60 x 0.56 mm. (Backside Coating included)

NTB0104UK

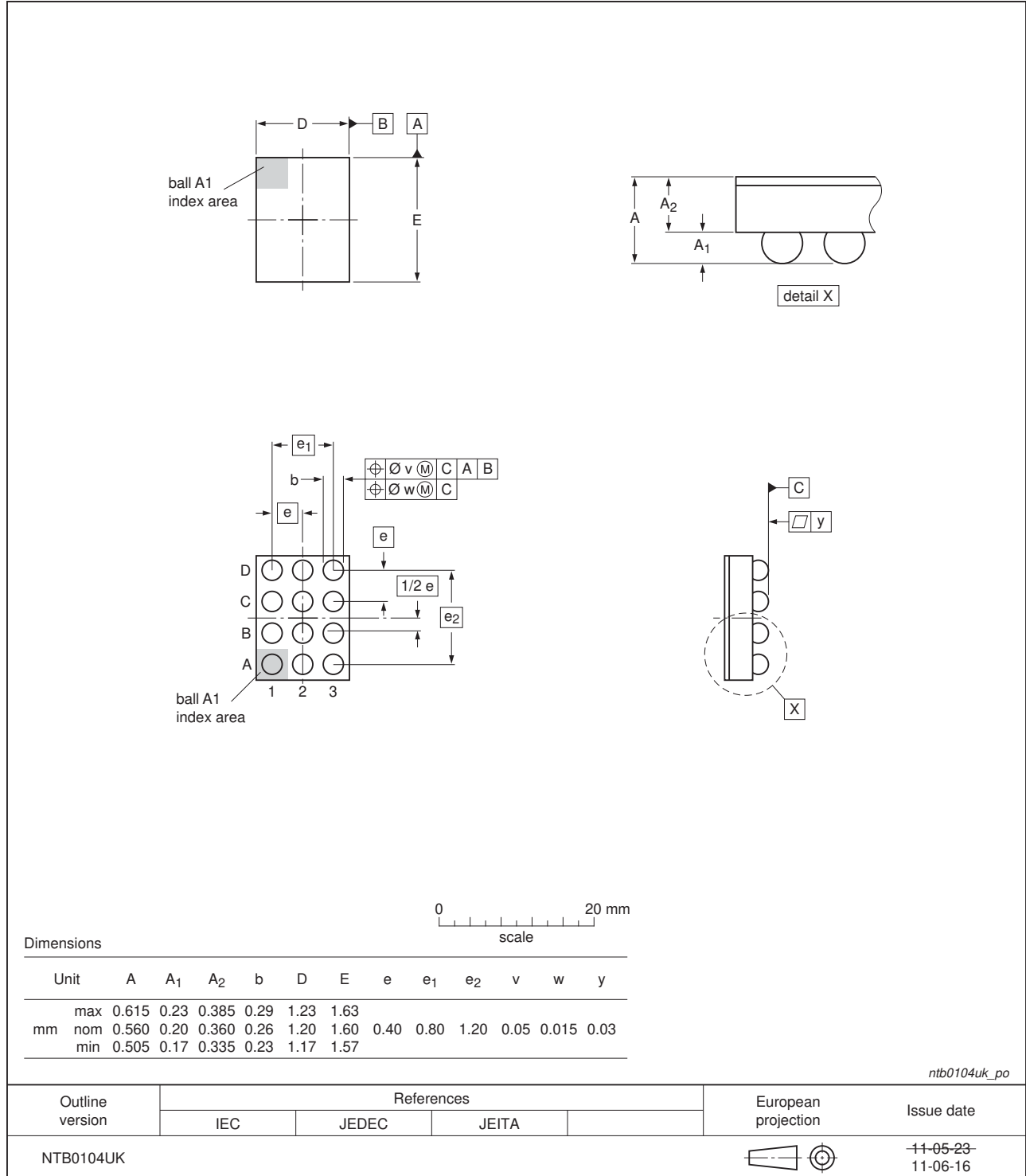

Fig 14. Package outline WLCSP12 package

14. Footprint information

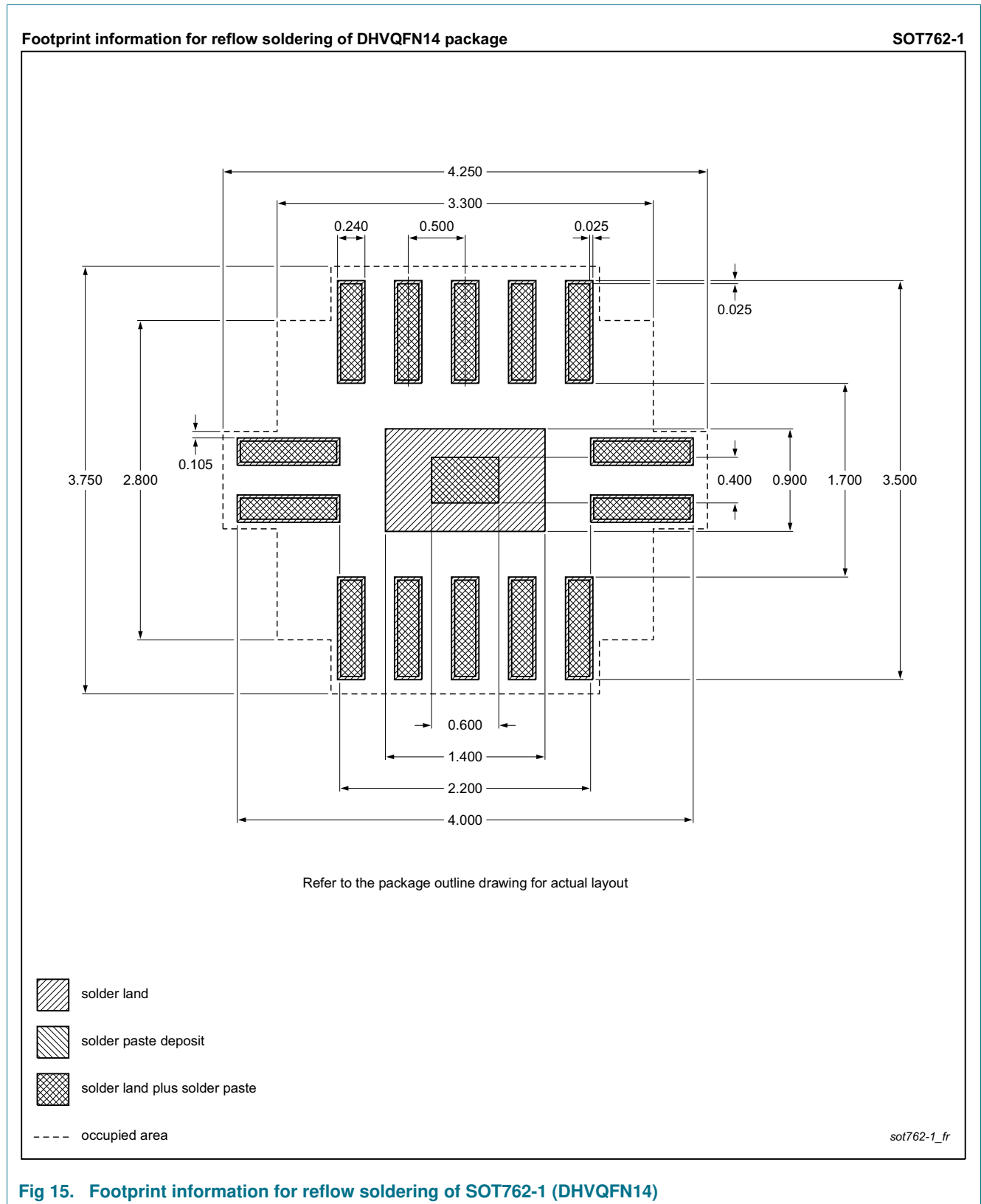

Fig 15. Footprint information for reflow soldering of SOT762-1 (DHVQFN14)

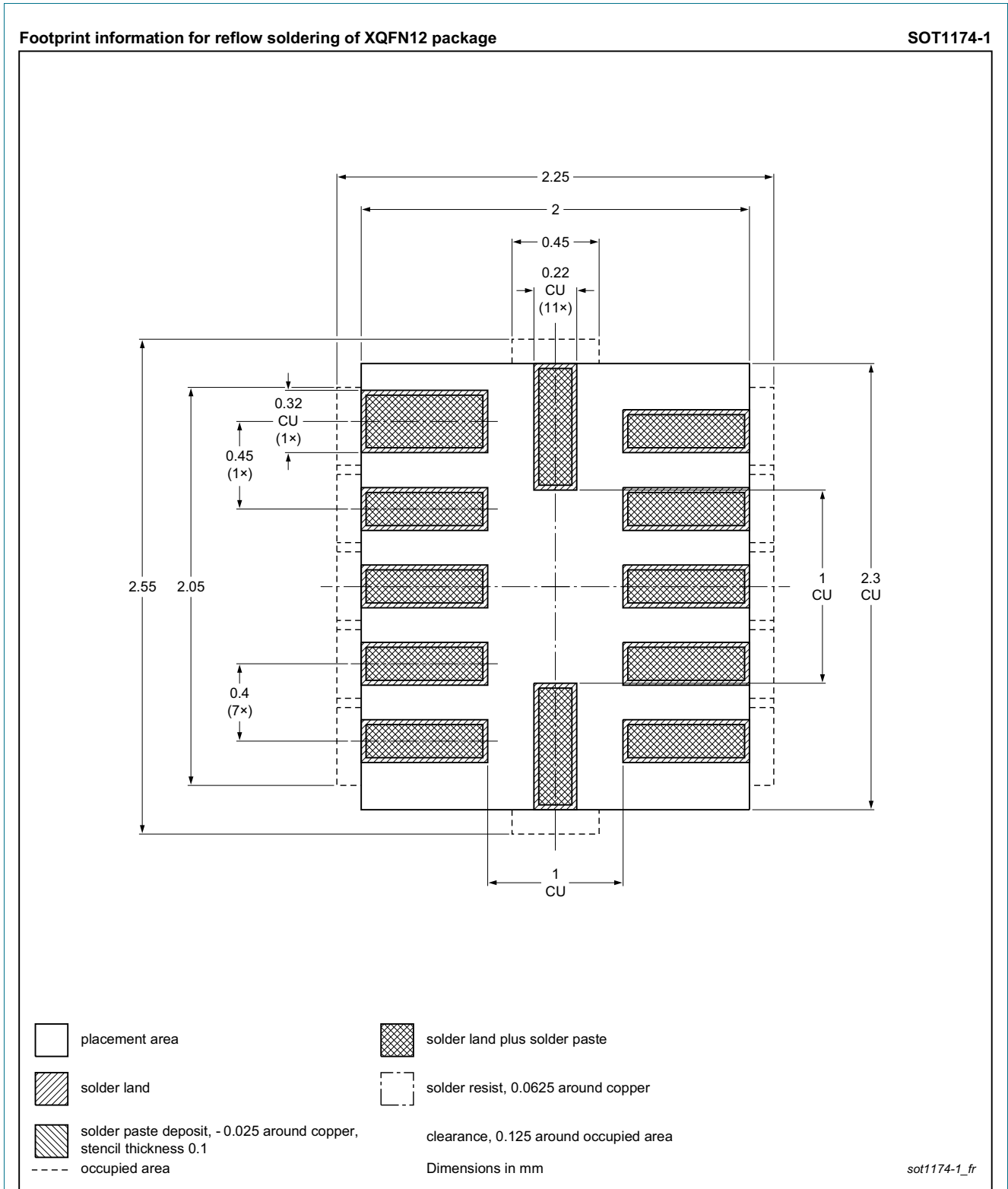

Fig 16. Footprint information for reflow soldering of SOT1174-1 (XQFN12)

15. Abbreviations

Table 16. Abbreviations

| Acronym | Description |
|---------|---|
| CDM | Charged Device Model |
| CMOS | Complementary Metal Oxide Semiconductor |
| DUT | Device Under Test |
| ESD | ElectroStatic Discharge |
| HBM | Human Body Model |
| MM | Machine Model |

16. Revision history

Table 17. Revision history

| Document ID | Release date | Data sheet status | Change notice | Supersedes |
|----------------|--|--------------------|---------------|-------------|
| NTB0104 v.4 | 20180419 | Product data sheet | - | NTB0104 v.3 |
| Modifications: | <ul style="list-style-type: none"> • Figure 12 “Package outline SOT762-1 (DHVQFN14)”: Added “k” heat pad to pin minimum gap dimension • Added Section 3.1 “Ordering options”, Section 14 “Footprint information” • Removed Section 4 “Marking” • Added topside marking to Table 1 “Ordering information” | | | |
| NTB0104 v.3 | 20111110 | Product data sheet | - | NTB0104 v.2 |
| Modifications: | <ul style="list-style-type: none"> • Legal pages updated. | | | |
| NTB0104 v.2 | 20111109 | Product data sheet | - | NTB0104 v.1 |
| NTB0104 v.1 | 20101026 | Product data sheet | - | - |