



Chipsmall Limited consists of a professional team with an average of over 10 year of expertise in the distribution of electronic components. Based in Hongkong, we have already established firm and mutual-benefit business relationships with customers from,Europe,America and south Asia,supplying obsolete and hard-to-find components to meet their specific needs.

With the principle of “Quality Parts,Customers Priority,Honest Operation,and Considerate Service”,our business mainly focus on the distribution of electronic components. Line cards we deal with include Microchip,ALPS,ROHM,Xilinx,Pulse,ON,Everlight and Freescale. Main products comprise IC,Modules,Potentiometer,IC Socket,Relay,Connector.Our parts cover such applications as commercial,industrial, and automotives areas.

We are looking forward to setting up business relationship with you and hope to provide you with the best service and solution. Let us make a better world for our industry!



Contact us

Tel: +86-755-8981 8866 Fax: +86-755-8427 6832

Email & Skype: info@chipsmall.com Web: www.chipsmall.com

Address: A1208, Overseas Decoration Building, #122 Zhenhua RD., Futian, Shenzhen, China



NTSX2102

Dual supply translating transceiver; open drain; auto direction sensing

Rev. 2 — 11 February 2013

Product data sheet

1. General description

The NTSX2102 is a 2-bit, dual supply translating transceiver with auto direction sensing, that enables bidirectional voltage level translation. It features two 2-bit input-output ports (An and Bn), one output enable input (OE) and two supply pins ($V_{CC(A)}$ and $V_{CC(B)}$). Both supplies can be supplied at any voltage between 1.65 V and 5.5 V. This flexibility makes the device suitable for translating between any of the voltage nodes (1.8 V, 2.5 V, 3.3 V and 5.0 V). Pins An and OE are referenced to $V_{CC(A)}$ and pins Bn are referenced to $V_{CC(B)}$. A LOW level at pin OE causes the outputs to assume a high-impedance OFF-state. This device is fully specified for partial power-down applications using I_{OFF} . The I_{OFF} circuitry disables the output, preventing the damaging backflow current through the device when it is powered down.

2. Features and benefits

- Wide supply voltage range:
 - ◆ $V_{CC(A)}$: 1.65 V to 5.5 V and $V_{CC(B)}$: 1.65 V to 5.5 V
- Maximum data rates:
 - ◆ 50 Mbps
- I_{OFF} circuitry provides partial Power-down mode operation
- Inputs accept voltages up to 5.5 V
- ESD protection:
 - ◆ HBM JS-001 Class 2 exceeds 2000 V
 - ◆ CDM JESD22-C101E exceeds 2000 V
- Latch-up performance exceeds 100 mA per JESD 78B Class II
- Multiple package options
- Specified from $-40\text{ }^{\circ}\text{C}$ to $+85\text{ }^{\circ}\text{C}$

3. Applications

- I²C/SMBus
- UART
- GPIO



4. Ordering information

Table 1. Ordering information

Type number	Package			Version
	Temperature range	Name	Description	
NTSX2102GM	-40 °C to +85 °C	XQFN8	plastic extremely thin quad flat package; no leads; 8 terminals; body 1.6 × 1.6 × 0.5 mm	SOT902-2
NTSX2102GU8	-40 °C to +85 °C	XQFN8	XQFN8: plastic, extremely thin quad flat package; no leads; 8 terminals; body 1.4 × 1.2 × 0.5 mm	SOT1309-1
NTSX2102GD	-40 °C to +85 °C	XSON8	plastic extremely thin small outline package; no leads; 8 terminals; body 3 × 2 × 0.5 mm	SOT996-2

5. Marking

Table 2. Marking

Type number	Marking code
NTSX2102GM	sX2
NTSX2102GU8	sX
NTSX2102GD	sX2

6. Functional diagram

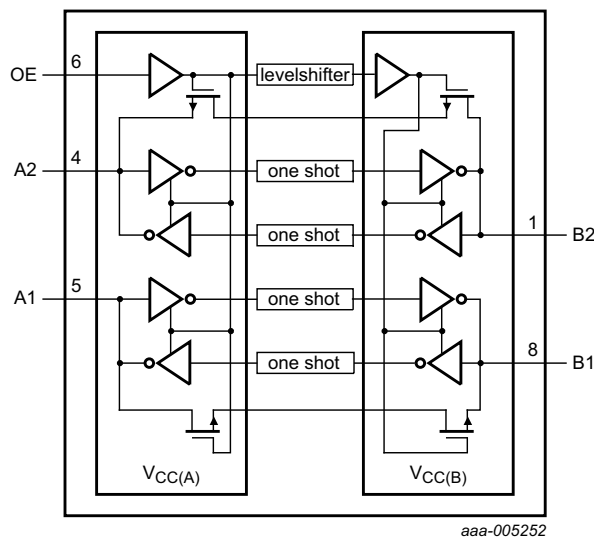

Fig 1. Logic symbol

7. Pinning information

7.1 Pinning

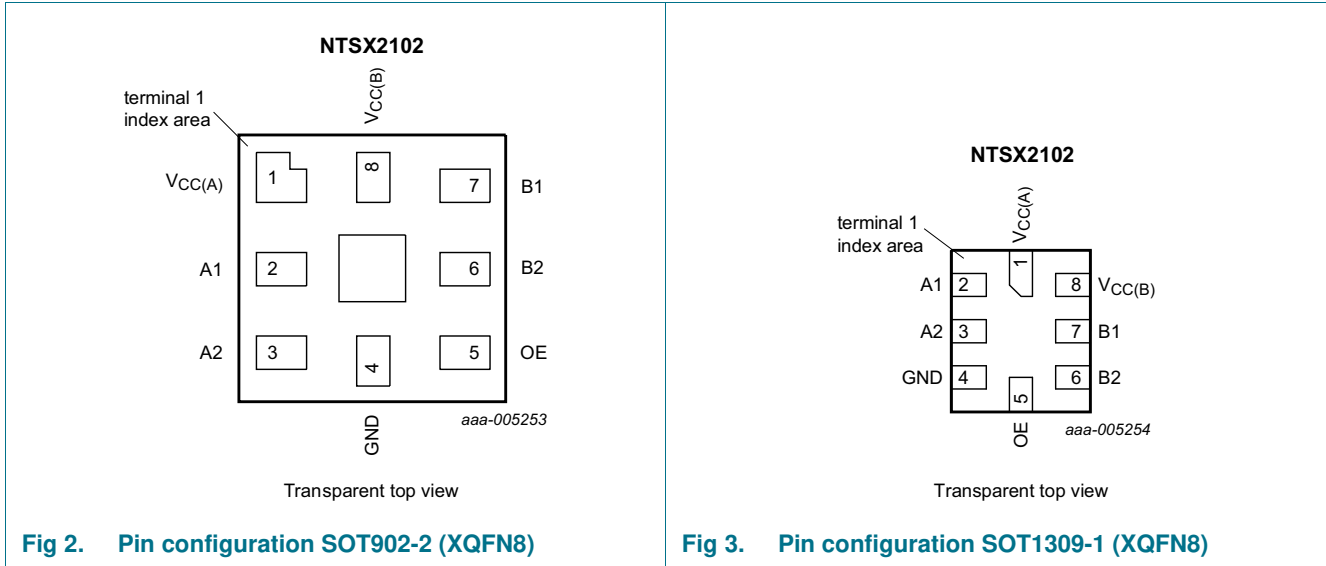

Fig 2. Pin configuration SOT902-2 (XQFN8)

Fig 3. Pin configuration SOT1309-1 (XQFN8)

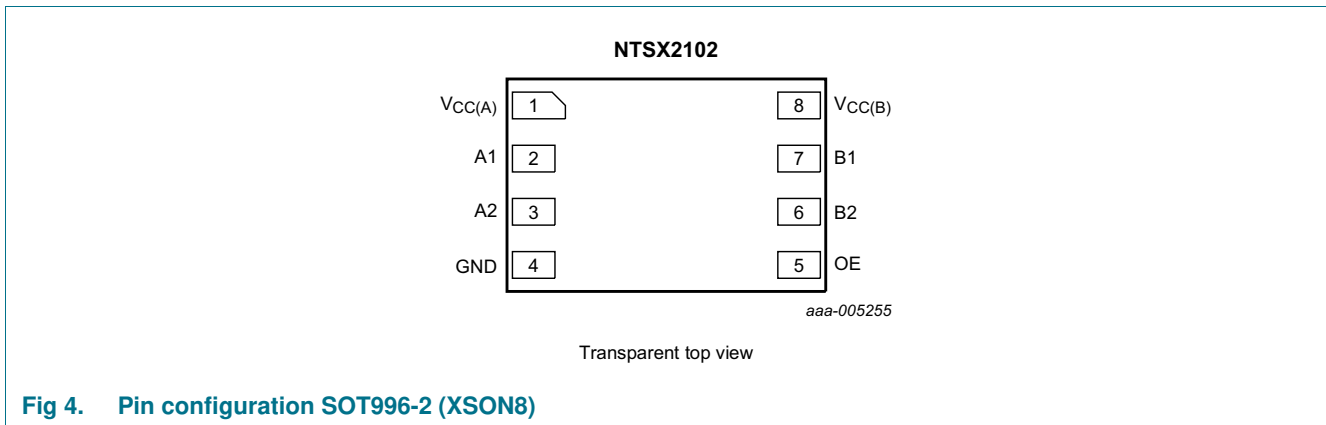

Fig 4. Pin configuration SOT996-2 (XSON8)

7.2 Pin description

Table 3. Pin description

Symbol	Pin	Description
B2, B1	6, 7	data input or output (referenced to V _{CC(B)})
GND	4	ground (0 V)
V _{CC(A)}	1	supply voltage A
A2, A1	3, 2	data input or output (referenced to V _{CC(A)})
OE	5	output enable input (active HIGH; referenced to V _{CC(A)})
V _{CC(B)}	8	supply voltage B

8. Functional description

Table 4. Function table^[1]

Supply voltage		Input	Input/output	
V _{CC(A)}	V _{CC(B)}	OE	An	Bn
1.65 V to 5.5 V	1.65 V to 5.5 V	L	Z	Z
1.65 V to 5.5 V	1.65 V to 5.5 V	H	input or output	output or input
GND ^[2]	GND ^[2]	X	Z	Z

[1] H = HIGH voltage level; L = LOW voltage level; X = don't care; Z = high-impedance OFF-state.

[2] When either V_{CC(A)} or V_{CC(B)} is at GND level, the device goes into power-down mode.

9. Limiting values

Table 5. Limiting values

In accordance with the Absolute Maximum Rating System (IEC 60134). Voltages are referenced to GND (ground = 0 V).

Symbol	Parameter	Conditions	Min	Max	Unit	
V _{CC(A)}	supply voltage A		-0.5	+6.5	V	
V _{CC(B)}	supply voltage B		-0.5	+6.5	V	
V _I	input voltage	A port and OE input	^{[1][2]}	-0.5	+6.5	V
		B port	^{[1][2]}	-0.5	+6.5	V
V _O	output voltage	Active mode	^{[1][2]}			
		A or B port		-0.5	V _{CCO} + 0.5	V
		Power-down or 3-state mode	^[1]			
	A or B port		-0.5	+6.5	V	
I _{IK}	input clamping current	V _I < 0 V	-50	-	mA	
I _{OK}	output clamping current	V _O < 0 V	-50	-	mA	
I _O	output current	V _O = 0 V to V _{CCO}	^[2]	±50	mA	
I _{CC}	supply current	I _{CC(A)} or I _{CC(B)}	-	100	mA	
I _{GND}	ground current		-100	-	mA	
T _{stg}	storage temperature		-65	+150	°C	
P _{tot}	total power dissipation	T _{amb} = -40 °C to +85 °C	-	250	mW	

[1] The minimum input and minimum output voltage ratings may be exceeded if the input and output current ratings are observed.

[2] V_{CCO} is the supply voltage associated with the output.

10. Recommended operating conditions

Table 6. Recommended operating conditions^[1]

Symbol	Parameter	Conditions	Min	Max	Unit
V _{CC(A)}	supply voltage A		1.65	5.5	V
V _{CC(B)}	supply voltage B		1.65	5.5	V

Table 6. Recommended operating conditions^[1] ...continued

Symbol	Parameter	Conditions	Min	Max	Unit
T _{amb}	ambient temperature		-40	+85	°C
Δt/ΔV	input transition rise and fall rate	A, B or OE port			
		V _{CC(A)} = 1.65 V to 5.5 V; V _{CC(B)} = 1.65 V to 5.5 V	-	10	ns/V

[1] Hold the A and B sides of an unused I/O pair in the same state, both at V_{CCI} or both at GND.

11. Static characteristics

Table 7. Typical static characteristics

At recommended operating conditions; voltages are referenced to GND (ground = 0 V); T_{amb} = 25 °C.

Symbol	Parameter	Conditions	Min	Typ	Max	Unit
C _i	input capacitance	OE input; V _{CC(A)} = V _{CC(B)} = 0 V	-	2.2	-	pF
C _{I/O}	input/output capacitance	A or B port; V _{CC(A)} = 5.0 V; V _{CC(B)} = 5.0 V	-	10	-	pF

[1] V_{CCO} is the supply voltage associated with the output.

Table 8. Static characteristics

At recommended operating conditions; voltages are referenced to GND (ground = 0 V).

Symbol	Parameter	Conditions	-40 °C to +85 °C		Unit
			Min	Max	
V _{IH}	HIGH-level input voltage	A or B port			
		V _{CC(A)} = 1.65 V to 5.5 V; V _{CC(B)} = 1.65 V to 5.5 V ^[1]	V _{CCI} - 0.4	-	V
		OE input			
		V _{CC(A)} = 1.65 V to 5.5 V; V _{CC(B)} = 1.65 V to 5.5 V	0.65V _{CC(A)}	-	V
V _{IL}	LOW-level input voltage	A or B port			
		V _{CC(A)} = 1.65 V to 5.5 V; V _{CC(B)} = 1.65 V to 5.5 V	-	0.4	V
		OE input			
		V _{CC(A)} = 1.65 V to 5.5 V; V _{CC(B)} = 1.65 V to 5.5 V	-	0.35V _{CC(A)}	V
V _{OL}	LOW-level output voltage	A or B port; I _O = 6 mA ^[2]			
		V _I ≤ 0.15 V; V _{CC(A)} = 1.65 V to 5.5 V; V _{CC(B)} = 1.65 V to 5.5 V	-	0.4	V
I _I	input leakage current	OE input; V _I = 0 V to V _{CC(A)} ; V _{CC(A)} = 1.65 V to 5.5 V; V _{CC(B)} = 1.65 V to 5.5 V	-	±1	μA
I _{OZ}	OFF-state output current	A or B port; V _O = 0 V or V _{CCO} ; V _{CC(A)} = 0 V to 5.5 V; V _{CC(B)} = 0 V to 5.5 V ^[2]	-	±2	μA
I _{OFF}	power-off leakage current	A port; V _I or V _O = 0 V to 5.5 V; V _{CC(A)} = 0 V; V _{CC(B)} = 0 V to 5.5 V	-	±2	μA
		B port; V _I or V _O = 0 V to 5.5 V; V _{CC(B)} = 0 V; V _{CC(A)} = 0 V to 5.5 V	-	±2	μA

Table 8. Static characteristics ...continued

At recommended operating conditions; voltages are referenced to GND (ground = 0 V).

Symbol	Parameter	Conditions	-40 °C to +85 °C		Unit
			Min	Max	
I _{CC}	supply current	V _I = 0 V or V _{CCI} ; I _O = 0 A [1]			
		I _{CC(A)}			
		V _{CC(A)} = 1.65 V to 5.5 V; V _{CC(B)} = 1.65 V to 5.5 V; OE = LOW or HIGH	-	5	μA
		V _{CC(A)} = 1.65 V to 5.5 V; V _{CC(B)} = 0 V	-	2	μA
		V _{CC(A)} = 0 V; V _{CC(B)} = 1.65 V to 5.5 V	-	-2	μA
		I _{CC(B)}			
		V _{CC(A)} = 1.65 V to 5.5 V; V _{CC(B)} = 1.65 V to 5.5 V; OE = LOW	-	5	μA
V _{CC(A)} = 1.65 V to 5.5 V; V _{CC(B)} = 0 V	-	-2	μA		
V _{CC(A)} = 0 V; V _{CC(B)} = 1.65 V to 5.5 V	-	2	μA		

[1] V_{CCI} is the supply voltage associated with the input.

[2] V_{CCO} is the supply voltage associated with the output.

12. Dynamic characteristics

Table 9. Typical dynamic characteristics for temperature 25 °C

Voltages are referenced to GND (ground = 0 V); for test circuit see [Figure 7](#); for waveforms see [Figure 5](#) and [Figure 6](#).

Symbol	Parameter	Conditions	V _{CCO} ^[1]				Unit
			1.8 V	2.5 V	3.3 V	5.0 V	
t _{TLH}	LOW to HIGH output transition time	A or B port	7	5	4	3	ns
t _{THL}	HIGH to LOW output transition time	A or B port	4	6	8	11	ns
C _{PD}	power dissipation capacitance	OE = V _{CC(A)} ; V _{CC(A)} = V _{CC(B)} ; [2] f _I = 400 kHz; V _I = V _{CCI} ^[3]	-	-	-	13.5	pF

[1] V_{CCO} is the supply voltage associated with the output.

[2] C_{PD} is used to determine the dynamic power dissipation (P_D in μW).

$$P_D = C_{PD} \times V_{CC}^2 \times f_i \times N + \Sigma(C_L \times V_{CC}^2 \times f_o) \text{ where:}$$

f_i = input frequency in MHz;

f_o = output frequency in MHz;

C_L = load capacitance in pF;

V_{CC} = supply voltage in V;

N = number of inputs switching;

Σ(C_L × V_{CC}² × f_o) = sum of the outputs.

[3] V_{CCI} is the supply voltage associated with the input.

Table 10. Dynamic characteristics for temperature range –40 °C to +85 °C^[1]

Voltages are referenced to GND (ground = 0 V); for test circuit see [Figure 7](#); for wave forms see [Figure 5](#) and [Figure 6](#).

Symbol	Parameter	Conditions	V _{CC(B)}								Unit	
			1.8 V ± 0.15 V		2.5 V ± 0.2 V		3.3 V ± 0.3 V		5.0 V ± 0.5 V			
			Typ	Max	Typ	Max	Typ	Max	Typ	Max		
V_{CC(A)} = 1.8 V ± 0.15 V												
t _{PHL}	HIGH to LOW propagation delay	A to B	3	7	3	6	3	5	5	7	ns	
t _{PLH}	LOW to HIGH propagation delay	A to B	5	12	5	8	4	8	4	7	ns	
t _{PHL}	HIGH to LOW propagation delay	B to A	3	7	3	6	3	5	5	7	ns	
t _{PLH}	LOW to HIGH propagation delay	B to A	5	12	1	3	1	2	1	2	ns	
t _{PZL}	OFF-state to LOW propagation delay	OE to A	9	16	9	18	10	14	10	15	ns	
		OE to B	9	16	6	12	6	12	6	14	ns	
t _{PLZ}	LOW to OFF-state propagation delay	OE to A	100	120	100	120	100	120	100	120	ns	
		OE to B	100	120	100	120	100	120	100	120	ns	
t _{sk(o)}	output skew time	between channels	[2]	-	1	-	1	-	1	-	1	ns
f _{data}	data rate		-	18	-	18	-	18	-	18	Mbps	
V_{CC(A)} = 2.5 V ± 0.2 V												
t _{PHL}	HIGH to LOW propagation delay	A to B	3	6	2	5	2	5	2	5	ns	
t _{PLH}	LOW to HIGH propagation delay	A to B	1	3	2	4	2.5	7	2.5	5	ns	
t _{PHL}	HIGH to LOW propagation delay	B to A	3	6	2	5	2	5	2	5	ns	
t _{PLH}	LOW to HIGH propagation delay	B to A	5	8	2	4	1.5	3	1	3	ns	
t _{PZL}	OFF-state to LOW propagation delay	OE to A	6	12	5	10	8	10	5	8	ns	
		OE to B	9	18	5	10	4.5	9	4	8	ns	
t _{PLZ}	LOW to OFF-state propagation delay	OE to A	100	120	100	120	100	120	100	120	ns	
		OE to B	100	120	100	120	100	120	100	120	ns	
t _{sk(o)}	output skew time	between channels	[2]	-	1	-	1	-	1	-	1	ns
f _{data}	data rate		-	18	-	32	-	32	-	32	Mbps	
V_{CC(A)} = 3.3 V ± 0.3 V												
t _{PHL}	HIGH to LOW propagation delay	A to B	3	5	2	5	2	4	2	4	ns	
t _{PLH}	LOW to HIGH propagation delay	A to B	1	2	1.5	3	1.5	3	2	4	ns	
t _{PHL}	HIGH to LOW propagation delay	B to A	3	5	2	5	2	4	2	4	ns	
t _{PLH}	LOW to HIGH propagation delay	B to A	4	8	2.5	7	1.5	3	1	3	ns	
t _{PZL}	OFF-state to LOW propagation delay	OE to A	6	12	4.5	9	6	9	4	7	ns	
		OE to B	10	14	5	10	6	9	4	8	ns	

Table 10. Dynamic characteristics for temperature range -40 °C to +85 °C^[1]

Voltages are referenced to GND (ground = 0 V); for test circuit see Figure 7; for wave forms see Figure 5 and Figure 6.

Symbol	Parameter	Conditions	V _{CC(B)}								Unit	
			1.8 V ± 0.15 V		2.5 V ± 0.2 V		3.3 V ± 0.3 V		5.0 V ± 0.5 V			
			Typ	Max	Typ	Max	Typ	Max	Typ	Max		
t _{PLZ}	LOW to OFF-state propagation delay	OE to A	100	120	100	120	100	120	100	120	ns	
		OE to B	100	120	100	120	100	120	100	120	ns	
t _{sk(o)}	output skew time	between channels	[2]	-	1	-	1	-	1	-	1	ns
f _{data}	data rate		-	18	-	32	-	40	-	40	Mbps	
V_{CC(A)} = 5.0 V ± 0.5 V												
t _{PHL}	HIGH to LOW propagation delay	A to B	5	7	2	5	2	4	2	4	ns	
t _{PLH}	LOW to HIGH propagation delay	A to B	1	2	1	3	1	3	1	3	ns	
t _{PHL}	HIGH to LOW propagation delay	B to A	5	7	2	5	2	4	2	4	ns	
t _{PLH}	LOW to HIGH propagation delay	B to A	4	7	2.5	5	2	4	1	3	ns	
t _{PZL}	OFF-state to LOW propagation delay	OE to A	6	14	4	8	4	8	3	5	ns	
		OE to B	10	15	5	8	4	7	4	5	ns	
t _{PLZ}	LOW to OFF-state propagation delay	OE to A	100	120	100	120	100	120	100	120	ns	
		OE to B	100	120	100	120	100	120	100	120	ns	
t _{sk(o)}	output skew time	between channels	[2]	-	1	-	1	-	1	-	1	ns
f _{data}	data rate		-	18	-	32	-	40	-	52	Mbps	

[1] All typical values are measured at nominal V_{CC} and T_{amb} = 25 °C.

[2] Skew between any two outputs of the same package switching in the same direction.

13. Waveforms

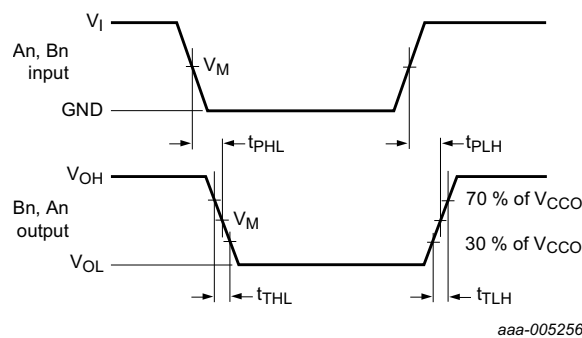

Measurement points are given in Table 11.

V_{OL} and V_{OH} are typical output voltage levels that occur with the output load.

Fig 5. The data input (An, Bn) to data output (Bn, An) propagation delay times

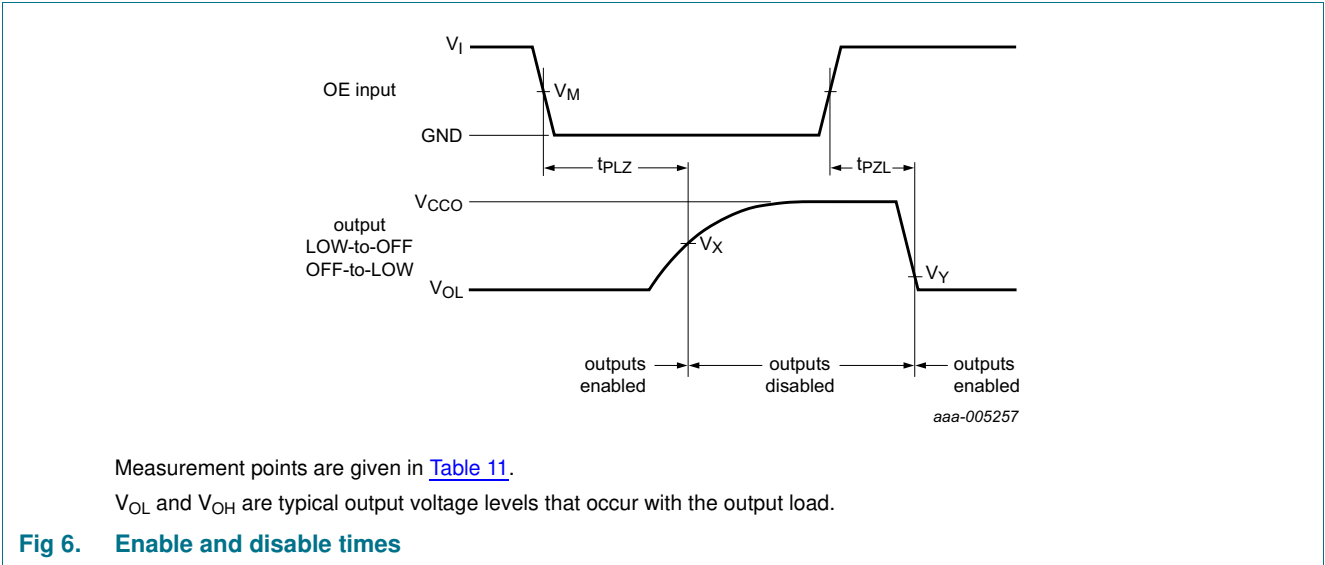
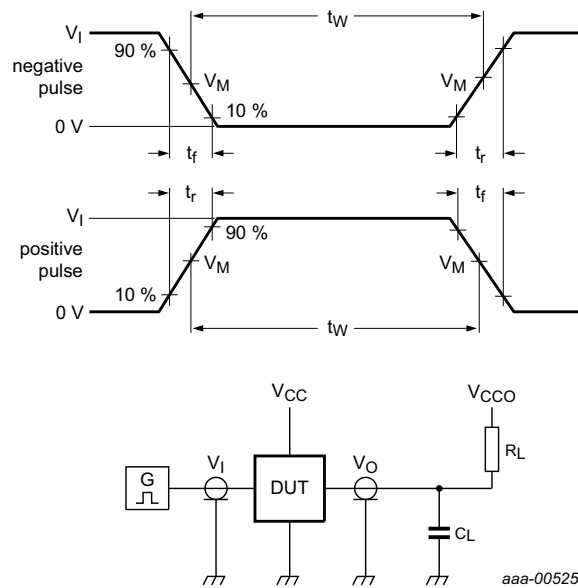

Table 11. Measurement points^{[1][2]}

Supply voltage	Input	Output		
V_{CCO}	V_M	V_M	V_X	V_Y
1.65 V to 5.5 V	$0.5V_{CCI}$	$0.5V_{CCO}$	$0.5V_{CCO}$	$0.1V_{CCO}$

- [1] V_{CCI} is the supply voltage associated with the input.
- [2] V_{CCO} is the supply voltage associated with the output.



Test data is given in [Table 12](#).

All input pulses are supplied by generators having the following characteristics: PRR ≤ 10 MHz; Z_O = 50 Ω; dV/dt ≥ 1.0 V/ns.

R_L = Load resistance.

C_L = Load capacitance including jig and probe capacitance.

V_{CC0} = Supply voltage associated with the output.

Fig 7. Test circuit for measuring switching times

Table 12. Test data

Supply voltage		Input		Load	
V _{CC(A)}	V _{CC(B)}	V _I [1]	t _r /t _f	C _L	R _L
1.65 V to 1.95 V	1.65 V to 1.95 V	V _{CCI}	≤ 2.0 ns	50 pF	2.2 kΩ
2.3 V to 2.7 V	2.3 V to 2.7 V	V _{CCI}	≤ 2.0 ns	50 pF	2.2 kΩ
3.0 V to 3.6 V	3.0 V to 3.6 V	V _{CCI}	≤ 2.5 ns	50 pF	2.2 kΩ
4.5 V to 5.5 V	4.5 V to 5.5 V	V _{CCI}	≤ 2.5 ns	50 pF	2.2 kΩ

[1] V_{CCI} is the supply voltage associated with the input.

During an input transition, a one-shot accelerates the output transition by switching on the PMOS transistors (T1, T3) for a LOW-to-HIGH transition. Alternatively, it switches on the NMOS transistors (T2, T4) for a HIGH-to-LOW transition. Once activated, the one-shot is de-activated after approximately 25 ns (see [Figure 11](#)). During the acceleration time, the driver output resistance is between approximately 10 Ω and 35 Ω. To avoid signal contention, the application must not exceed the maximum data rate or wait for the one-shot circuit to turn-off, before applying a signal in the opposite direction.

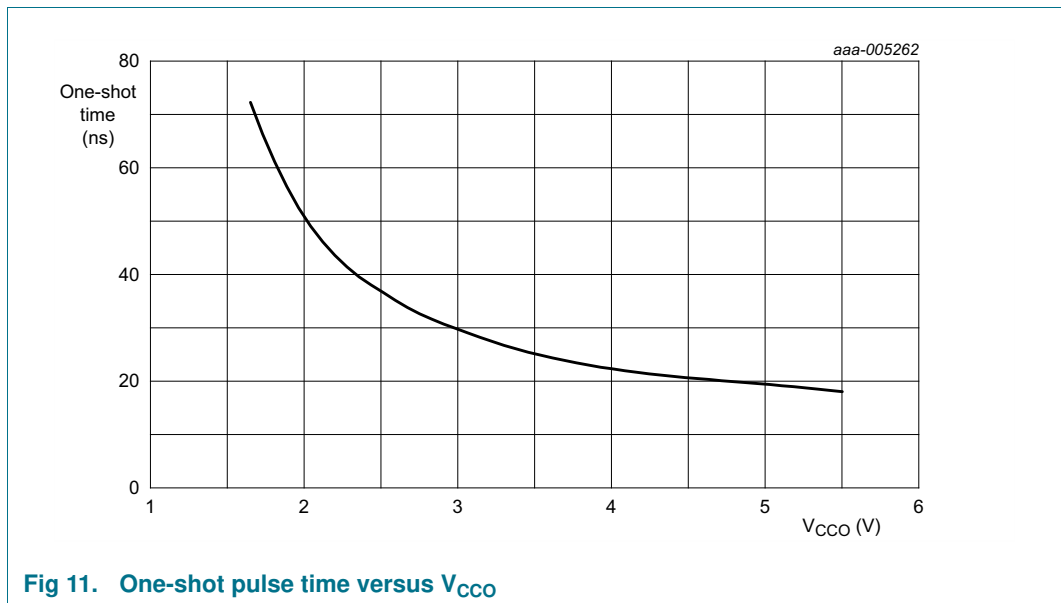
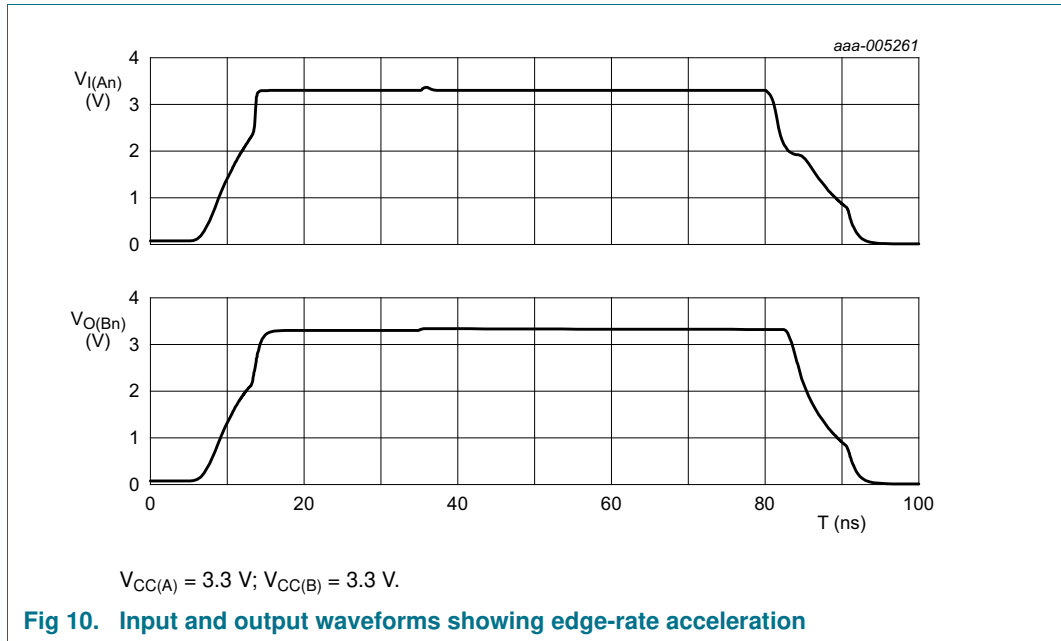

14.3 Input driver requirements

As the NTSX2102 is a switch type translator, properties of the input driver directly affect the output signal. The external open-drain driver applied to an I/O, determines the static current sinking capability of the system. The maximum data rate, output transition times (t_{THL} , t_{TLH}) and propagation delays (t_{PHL} , t_{PLH}) are dependent upon the output impedance and edge-rate of the external driver.

14.4 Output load considerations

The maximum lumped capacitive load that can be driven is dependent upon the one-shot pulse duration and has been tuned to 600 pF. In cases with higher capacitive loading, there is a risk that the output does not reach the positive rail within the one-shot pulse duration. To avoid excessive capacitive loading and to ensure correct triggering of the one-shot, use short trace lengths and low capacitance connectors on NTSX2102 PCB layouts. The length of the PCB trace should be such that the round-trip delay of any reflection is within the one-shot pulse duration. Such a length ensures low impedance termination and avoids output signal oscillations and one-shot retriggering.

14.5 Output enable (OE)

An output enable input (OE) is used to disable the device. Setting OE = LOW causes all I/Os to assume the high-impedance OFF-state.

14.6 Power-up

When either of the supplies $V_{CC(n)}$ is at 0 V, outputs are in the high-impedance OFF-state. One of the advantages of NTSX translators is that either $V_{CC(A)}$ or $V_{CC(B)}$ may be powered up first. To reduce dissipation during power-up, ensure that output enable (OE) is defined. Connect it via a pull down resistor to GND or, if the application allows, hardwired to $V_{CC(A)}$. If the OE pin is hardwired to $V_{CC(A)}$, either supply can be powered up or down first. If a pull down is used, the following sequences are recommended.

For power-up:

1. Apply power to either supply pin
2. Apply power to other supply pin
3. Enable the device by driving OE HIGH

For power down:

1. Disable the device by driving OE LOW
2. Remove power from either supply pin
3. Remove power from other supply pin

14.7 Pull-up resistors on I/O lines

Each A port I/O requires a pull-up resistor to $V_{CC(A)}$, and each B port I/O requires a pull-up resistor to $V_{CC(B)}$. Choose the magnitude of the pull-up resistors to ensure that the output voltage levels meet the application requirement.

15. Package outline

XQFN8: plastic, extremely thin quad flat package; no leads;
8 terminals; body 1.6 x 1.6 x 0.5 mm

SOT902-2

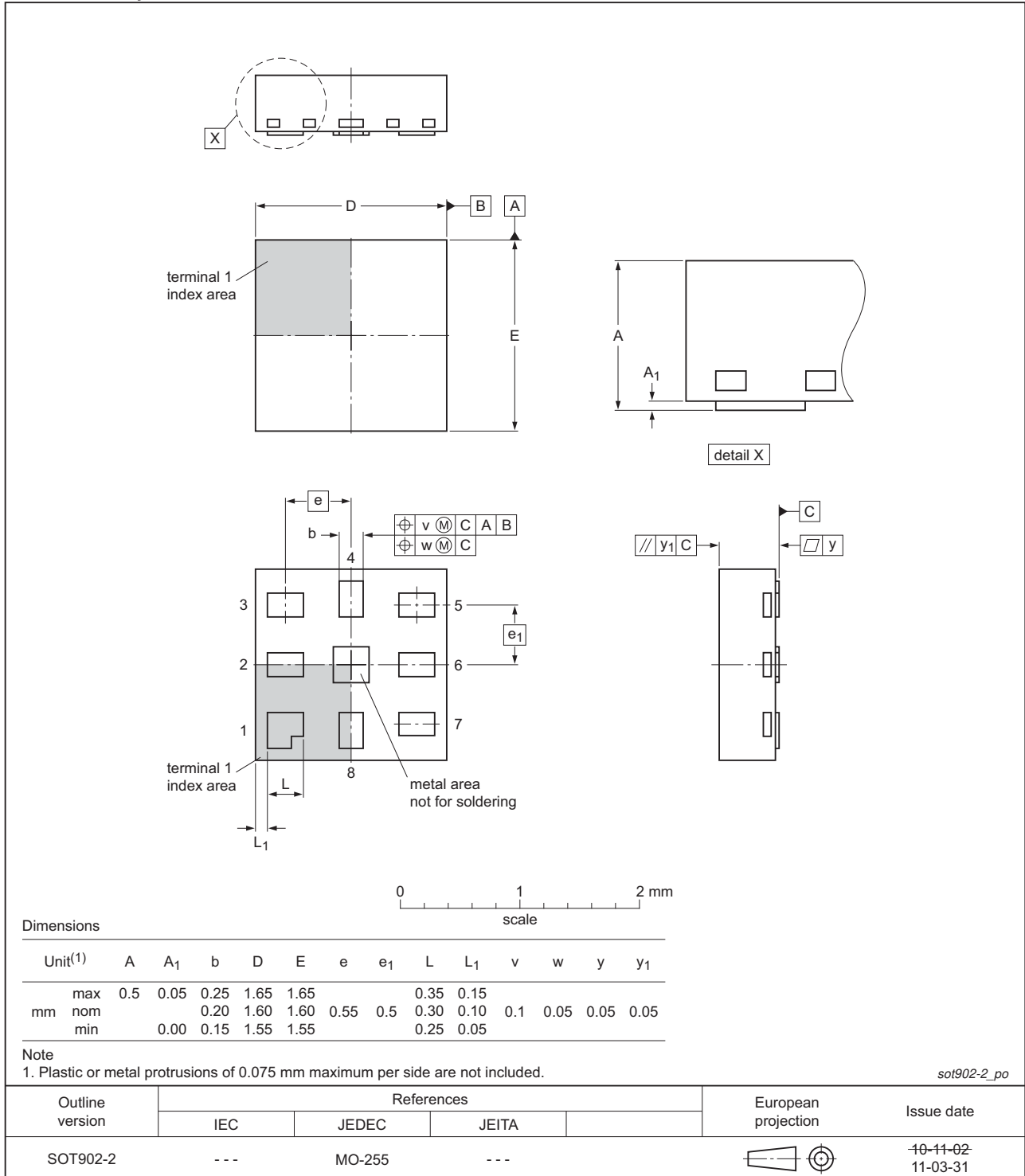

Fig 12. Package outline SOT902-2 (XQFN8)

XQFN8: plastic, extremely thin quad flat package; no leads;
8 terminals; body 1.4 x 1.2 x 0.5 mm

SOT1309-1

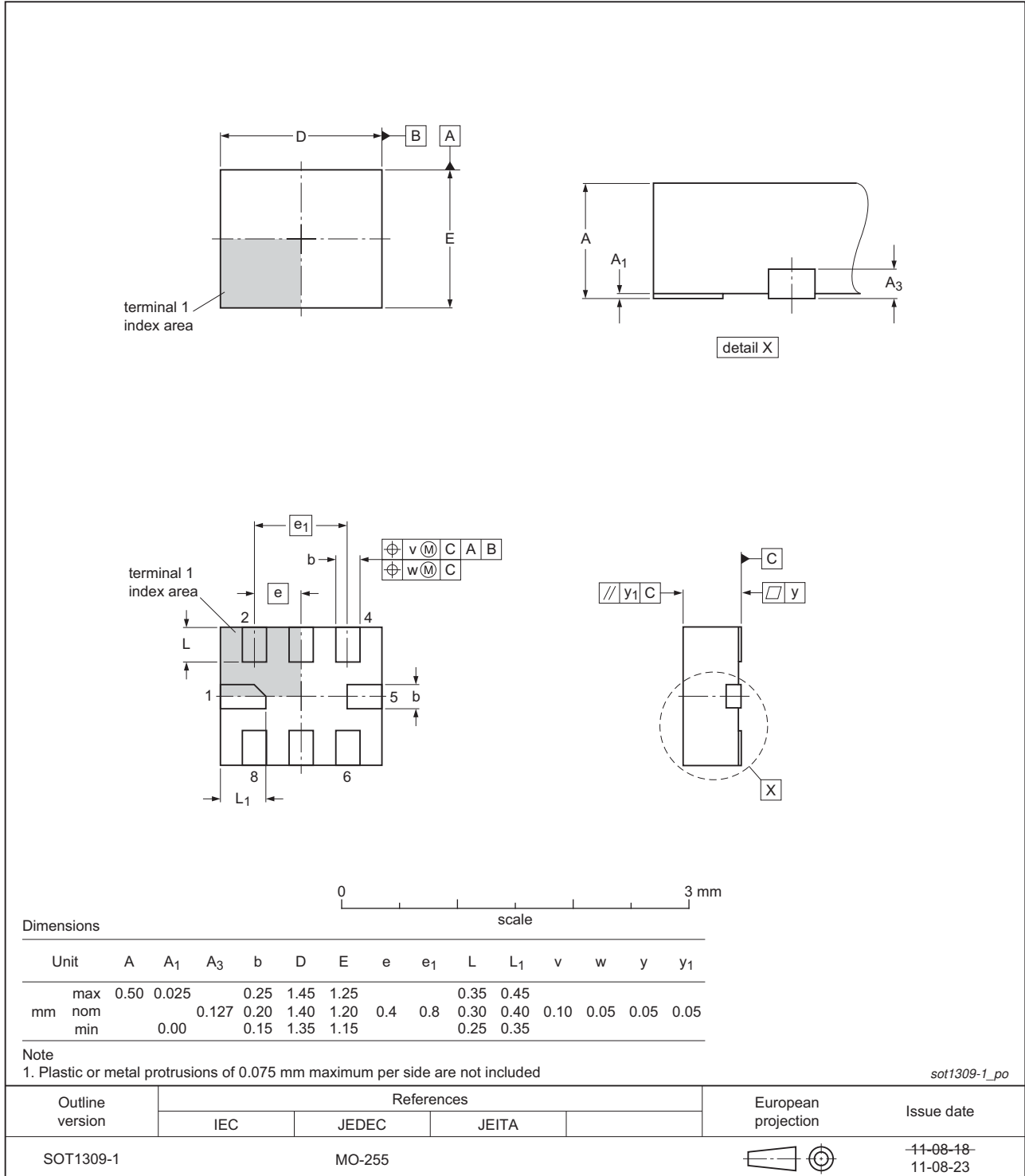

Fig 13. Package outline SOT1309-1 (XQFN8)

XSON8: plastic extremely thin small outline package; no leads;
8 terminals; body 3 x 2 x 0.5 mm

SOT996-2

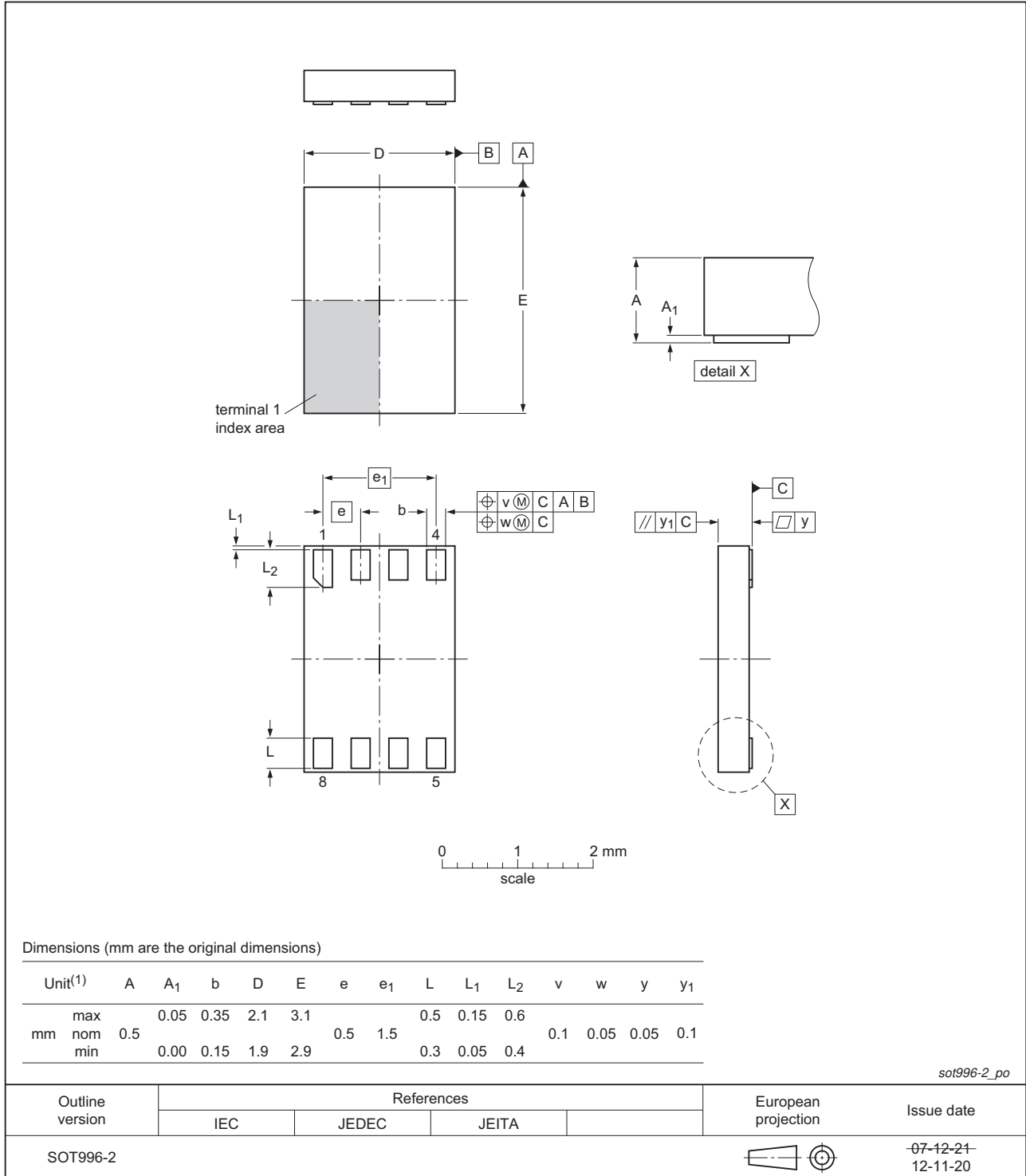

Fig 14. Package outline SOT996-2 (XSON8)

16. Abbreviations

Table 13. Abbreviations

Acronym	Description
CDM	Charged Device Model
CMOS	Complementary Metal Oxide Semiconductor
DUT	Device Under Test
ESD	ElectroStatic Discharge
GPIO	General Purpose Input Output
HBM	Human Body Model
I ² C	Inter-Integrated Circuit
PCB	Printed Circuit Board
PMOS	Positive Metal Oxide Semiconductor
SMBus	System Management Bus
UART	Universal Asynchronous Receiver Transmitter
UTLP	Ultra Thin Leadless Package

17. Revision history

Table 14. Revision history

Document ID	Release date	Data sheet status	Change notice	Supersedes
NTSX2102 v.2	20130211	Product data sheet	-	NTSX2102 v.1.1
Modifications:	<ul style="list-style-type: none"> For type number NTSX2102GD XSON8U has changed to XSON8. 			
NTSX2102 v.1.1	20121121	Product data sheet	-	NTSX2102 v.1
Modifications:	<ul style="list-style-type: none"> Section 1 "General description" text updated. 			
NTSX2102 v.1	20121119	Product data sheet	-	-

18. Legal information

18.1 Data sheet status

Document status ^{[1][2]}	Product status ^[3]	Definition
Objective [short] data sheet	Development	This document contains data from the objective specification for product development.
Preliminary [short] data sheet	Qualification	This document contains data from the preliminary specification.
Product [short] data sheet	Production	This document contains the product specification.

[1] Please consult the most recently issued document before initiating or completing a design.

[2] The term 'short data sheet' is explained in section "Definitions".

[3] The product status of device(s) described in this document may have changed since this document was published and may differ in case of multiple devices. The latest product status information is available on the Internet at URL <http://www.nxp.com>.

18.2 Definitions

Draft — The document is a draft version only. The content is still under internal review and subject to formal approval, which may result in modifications or additions. NXP Semiconductors does not give any representations or warranties as to the accuracy or completeness of information included herein and shall have no liability for the consequences of use of such information.

Short data sheet — A short data sheet is an extract from a full data sheet with the same product type number(s) and title. A short data sheet is intended for quick reference only and should not be relied upon to contain detailed and full information. For detailed and full information see the relevant full data sheet, which is available on request via the local NXP Semiconductors sales office. In case of any inconsistency or conflict with the short data sheet, the full data sheet shall prevail.

Product specification — The information and data provided in a Product data sheet shall define the specification of the product as agreed between NXP Semiconductors and its customer, unless NXP Semiconductors and customer have explicitly agreed otherwise in writing. In no event however, shall an agreement be valid in which the NXP Semiconductors product is deemed to offer functions and qualities beyond those described in the Product data sheet.

18.3 Disclaimers

Limited warranty and liability — Information in this document is believed to be accurate and reliable. However, NXP Semiconductors does not give any representations or warranties, expressed or implied, as to the accuracy or completeness of such information and shall have no liability for the consequences of use of such information. NXP Semiconductors takes no responsibility for the content in this document if provided by an information source outside of NXP Semiconductors.

In no event shall NXP Semiconductors be liable for any indirect, incidental, punitive, special or consequential damages (including - without limitation - lost profits, lost savings, business interruption, costs related to the removal or replacement of any products or rework charges) whether or not such damages are based on tort (including negligence), warranty, breach of contract or any other legal theory.

Notwithstanding any damages that customer might incur for any reason whatsoever, NXP Semiconductors' aggregate and cumulative liability towards customer for the products described herein shall be limited in accordance with the *Terms and conditions of commercial sale* of NXP Semiconductors.

Right to make changes — NXP Semiconductors reserves the right to make changes to information published in this document, including without limitation specifications and product descriptions, at any time and without notice. This document supersedes and replaces all information supplied prior to the publication hereof.

Suitability for use — NXP Semiconductors products are not designed, authorized or warranted to be suitable for use in life support, life-critical or safety-critical systems or equipment, nor in applications where failure or malfunction of an NXP Semiconductors product can reasonably be expected to result in personal injury, death or severe property or environmental damage. NXP Semiconductors and its suppliers accept no liability for inclusion and/or use of NXP Semiconductors products in such equipment or applications and therefore such inclusion and/or use is at the customer's own risk.

Applications — Applications that are described herein for any of these products are for illustrative purposes only. NXP Semiconductors makes no representation or warranty that such applications will be suitable for the specified use without further testing or modification.

Customers are responsible for the design and operation of their applications and products using NXP Semiconductors products, and NXP Semiconductors accepts no liability for any assistance with applications or customer product design. It is customer's sole responsibility to determine whether the NXP Semiconductors product is suitable and fit for the customer's applications and products planned, as well as for the planned application and use of customer's third party customer(s). Customers should provide appropriate design and operating safeguards to minimize the risks associated with their applications and products.

NXP Semiconductors does not accept any liability related to any default, damage, costs or problem which is based on any weakness or default in the customer's applications or products, or the application or use by customer's third party customer(s). Customer is responsible for doing all necessary testing for the customer's applications and products using NXP Semiconductors products in order to avoid a default of the applications and the products or of the application or use by customer's third party customer(s). NXP does not accept any liability in this respect.

Limiting values — Stress above one or more limiting values (as defined in the Absolute Maximum Ratings System of IEC 60134) will cause permanent damage to the device. Limiting values are stress ratings only and (proper) operation of the device at these or any other conditions above those given in the Recommended operating conditions section (if present) or the Characteristics sections of this document is not warranted. Constant or repeated exposure to limiting values will permanently and irreversibly affect the quality and reliability of the device.

Terms and conditions of commercial sale — NXP Semiconductors products are sold subject to the general terms and conditions of commercial sale, as published at <http://www.nxp.com/profile/terms>, unless otherwise agreed in a valid written individual agreement. In case an individual agreement is concluded only the terms and conditions of the respective agreement shall apply. NXP Semiconductors hereby expressly objects to applying the customer's general terms and conditions with regard to the purchase of NXP Semiconductors products by customer.

No offer to sell or license — Nothing in this document may be interpreted or construed as an offer to sell products that is open for acceptance or the grant, conveyance or implication of any license under any copyrights, patents or other industrial or intellectual property rights.

Export control — This document as well as the item(s) described herein may be subject to export control regulations. Export might require a prior authorization from competent authorities.

Non-automotive qualified products — Unless this data sheet expressly states that this specific NXP Semiconductors product is automotive qualified, the product is not suitable for automotive use. It is neither qualified nor tested in accordance with automotive testing or application requirements. NXP Semiconductors accepts no liability for inclusion and/or use of non-automotive qualified products in automotive equipment or applications.

In the event that customer uses the product for design-in and use in automotive applications to automotive specifications and standards, customer (a) shall use the product without NXP Semiconductors' warranty of the

product for such automotive applications, use and specifications, and (b) whenever customer uses the product for automotive applications beyond NXP Semiconductors' specifications such use shall be solely at customer's own risk, and (c) customer fully indemnifies NXP Semiconductors for any liability, damages or failed product claims resulting from customer design and use of the product for automotive applications beyond NXP Semiconductors' standard warranty and NXP Semiconductors' product specifications.

18.4 Trademarks

Notice: All referenced brands, product names, service names and trademarks are the property of their respective owners.

19. Contact information

For more information, please visit: <http://www.nxp.com>

For sales office addresses, please send an email to: salesaddresses@nxp.com

20. Contents

1	General description	1
2	Features and benefits	1
3	Applications	1
4	Ordering information	2
5	Marking	2
6	Functional diagram	2
7	Pinning information	3
7.1	Pinning	3
7.2	Pin description	3
8	Functional description	4
9	Limiting values	4
10	Recommended operating conditions	4
11	Static characteristics	5
12	Dynamic characteristics	6
13	Waveforms	8
14	Application information	11
14.1	Applications	11
14.2	Architecture	11
14.3	Input driver requirements	13
14.4	Output load considerations	13
14.5	Output enable (OE)	13
14.6	Power-up	13
14.7	Pull-up resistors on I/O lines	13
15	Package outline	14
16	Abbreviations	17
17	Revision history	17
18	Legal information	18
18.1	Data sheet status	18
18.2	Definitions	18
18.3	Disclaimers	18
18.4	Trademarks	19
19	Contact information	19
20	Contents	20

Please be aware that important notices concerning this document and the product(s) described herein, have been included in section 'Legal information'.

© NXP B.V. 2013.

All rights reserved.

For more information, please visit: <http://www.nxp.com>

For sales office addresses, please send an email to: salesaddresses@nxp.com

Date of release: 11 February 2013

Document identifier: NTSX2102