



Chipsmall Limited consists of a professional team with an average of over 10 year of expertise in the distribution of electronic components. Based in Hongkong, we have already established firm and mutual-benefit business relationships with customers from,Europe,America and south Asia,supplying obsolete and hard-to-find components to meet their specific needs.

With the principle of “Quality Parts,Customers Priority,Honest Operation,and Considerate Service”,our business mainly focus on the distribution of electronic components. Line cards we deal with include Microchip,ALPS,ROHM,Xilinx,Pulse,ON,Everlight and Freescale. Main products comprise IC,Modules,Potentiometer,IC Socket,Relay,Connector.Our parts cover such applications as commercial,industrial, and automotives areas.

We are looking forward to setting up business relationship with you and hope to provide you with the best service and solution. Let us make a better world for our industry!



Contact us

Tel: +86-755-8981 8866 Fax: +86-755-8427 6832

Email & Skype: info@chipsmall.com Web: www.chipsmall.com

Address: A1208, Overseas Decoration Building, #122 Zhenhua RD., Futian, Shenzhen, China





Test Procedure for the NV47701PDAJGEVB Evaluation Board

Test Procedure:

1. Connect the test setup as is shown in **Figure 1**. See **Table 1** with required equipment.
 - Letter **F** – Force line
 - Letter **S** – Sense line
2. Select output current limit by connecting jumper **J₅** – **J₈**.
 - **J₅** – $I_{LIM0} \sim 10$ mA
 - **J₆** – $I_{LIM1} \sim 170$ mA
 - **J₇** – $I_{LIM2} \sim 340$ mA
 - **J₈** – I_{LIM3} – R_{CSO3} position available for individual current limit setting by resistor from range 728Ω to 25.5 k Ω
3. Set Input Voltage and turn on Power Supply.
4. Enable chip by connecting jumper **J₃** to V_{in} or by external Voltage Source. Output Voltage must be higher than 3.5 V.
5. Set load current (max 350 mA) and turn on Load.
6. Monitor Output voltage, it's given according to Equation 1.

$$V_{out} = 1.275 \left(1 + \frac{R_1}{R_2} \right) \quad (\text{eq. 1})$$

7. Monitor CSO voltage on connector **J₄**. It should be max 2.55 V in steady state. The CSO voltage is proportional to output current according to Equation 2.

$$V_{CSO} = I_{out} \left(R_{CSO} \times \frac{1}{100} \right) \quad (\text{eq. 2})$$

8. Compare your results with measured results in **Table 2**.

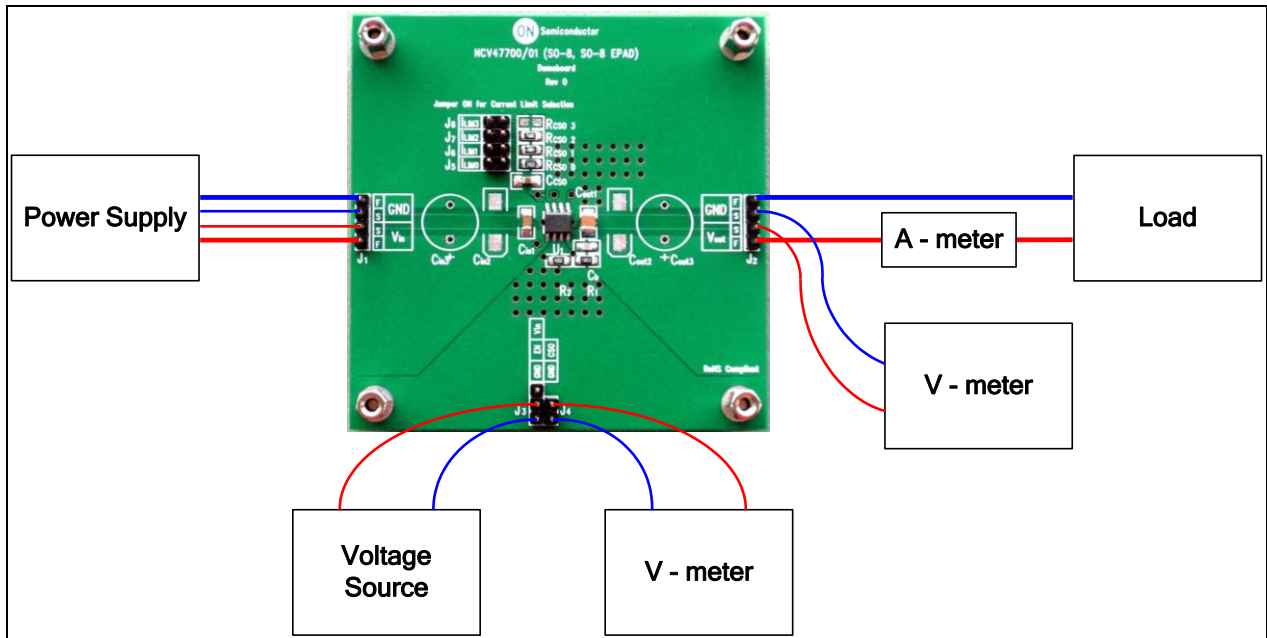

Figure 1. Test Setup

Table 1: Required Equipment

Equipment	Ranges
Power Supply	0 V – 45 V / 500 mA
Voltage Source	0 V – 45 V
Load	0 mA – 500 mA
V - meter	0 V – 20 V
A - meter	0 mA – 500 mA

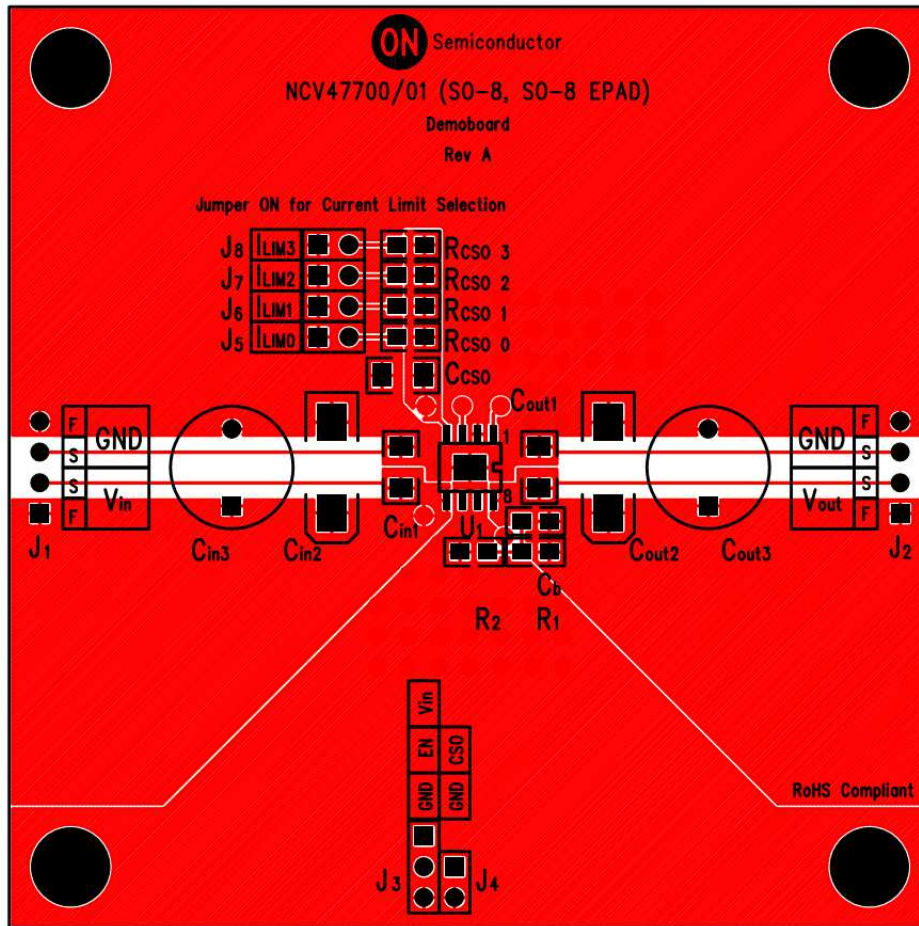

Figure 2. PCB Layout

Table 2: Measured Results

Parameter	Test Conditions	Value		Unit
		Nominal	Measured	
Output Voltage	$V_{in} = 13.5\text{ V}$, $V_{out_nom} = 5.02\text{ V}$, $I_{out} = 5\text{ mA}$, $R_{CSO} = \text{Short to ground}$	5.02	5.03	V
	$V_{in} = 13.5\text{ V}$, $V_{out_nom} = 5.02\text{ V}$, $I_{out} = 350\text{ mA}$, $R_{CSO} = \text{Short to ground}$	5.02	5.04	
Output Current	$V_{in} = 13.5\text{ V}$, $V_{out_nom} = 5.02\text{ V}$, $V_{out} = 0\text{ V}$, $R_{CSO} = 25.5\text{ k}\Omega$	10	10.45	mA
	$V_{in} = 13.5\text{ V}$, $V_{out_nom} = 5.02\text{ V}$, $V_{out} = 0\text{ V}$, $R_{CSO} = 1.5\text{ k}\Omega$	170	175.6	
	$V_{in} = 13.5\text{ V}$, $V_{out_nom} = 5.02\text{ V}$, $V_{out} = 0\text{ V}$, $R_{CSO} = 750\ \Omega$	340	353	