



Chipsmall Limited consists of a professional team with an average of over 10 year of expertise in the distribution of electronic components. Based in Hongkong, we have already established firm and mutual-benefit business relationships with customers from,Europe,America and south Asia,supplying obsolete and hard-to-find components to meet their specific needs.

With the principle of “Quality Parts,Customers Priority,Honest Operation,and Considerate Service”,our business mainly focus on the distribution of electronic components. Line cards we deal with include Microchip,ALPS,ROHM,Xilinx,Pulse,ON,Everlight and Freescale. Main products comprise IC,Modules,Potentiometer,IC Socket,Relay,Connector.Our parts cover such applications as commercial,industrial, and automotives areas.

We are looking forward to setting up business relationship with you and hope to provide you with the best service and solution. Let us make a better world for our industry!



Contact us

Tel: +86-755-8981 8866 Fax: +86-755-8427 6832

Email & Skype: info@chipsmall.com Web: www.chipsmall.com

Address: A1208, Overseas Decoration Building, #122 Zhenhua RD., Futian, Shenzhen, China



THIS COPY IS PROVIDED ON A RESTRICTED BASIS AND IS NOT TO BE USED IN ANY WAY DETRIMENTAL TO THE INTERESTS OF PANDUIT CORP.

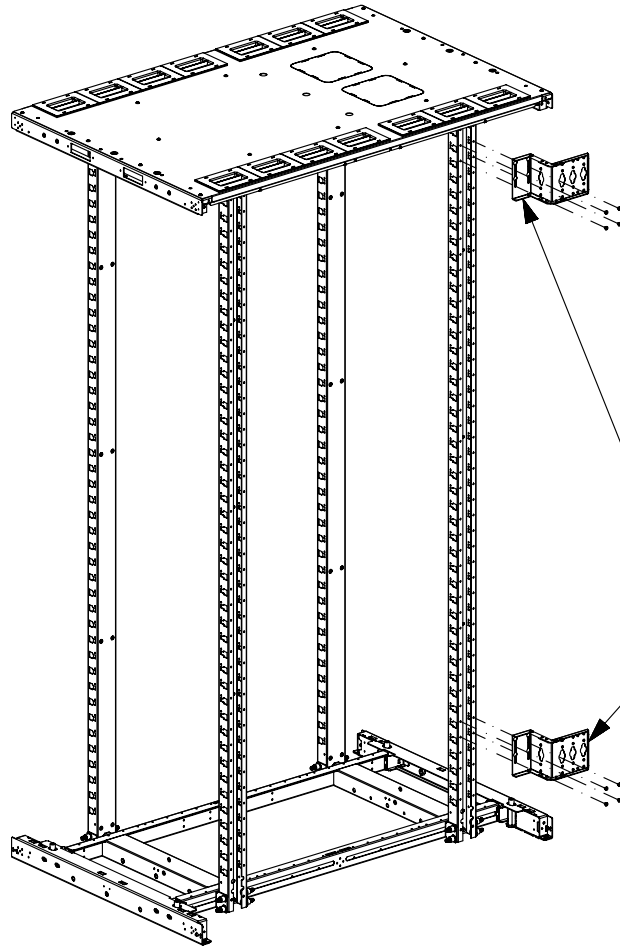

PDU MOUNTING BRACKET CAN BE ADJUSTED VERTICALLY ALONG CABINET PER RACK SPACE

APPLICATION VIEW
CABINET NOT INCLUDED

PANDUIT P/N	WEIGHT
NVPDUB	2.0 Kg/EACH 4.4 LBS/EACH

NOTES:

- VISIT OUR ON-LINE CATALOG AT WWW.PANDUIT.COM FOR A LIST OF CURRENT PARTS APPLICABLE FOR USE WITH THIS PRODUCT.
- PRIMARY DIMENSIONS ARE IN MILLIMETERS (mm).
- PARTS SUPPLIED:
(2) - PDU BRACKETS
(8) - TORX SCREWS
(1) - INSTRUCTION SHEET

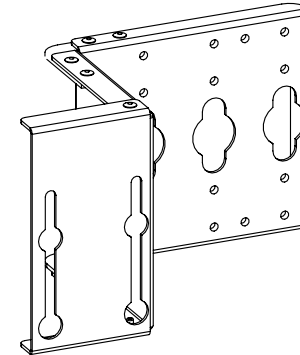

ISO VIEW

OOA	9-18-13	PBS			RELEASED TO PRODUCTION			11V223GS-DC
REV	DATE	BY	CHK	APR	DESCRIPTION	ECN		

TITLE NVPDUB NET ACCESS N-TYPE PDU BRACKET FG CUSTOMER DRAWING			
ITEM REVISION NAME 11V223GS/00.PRT		MATERIAL/COLOR:	
DATASET FILE NAME 11V223GS_DC/00A.PRT		PANDUIT ™	
UNLESS OTHERWISE SPECIFIED, DIMENSIONAL TOLERANCES ARE:			
INCHES	METRIC - MILLIMETER	ANGLE	
X.X +/- 0.06	X +/- 1.5	+/- 1°	
X.XX +/- 0.03	X.X +/- 0.8		
X.XXX +/- 0.015	X.XX +/- 0.4		
DRAWING NUMBER: 11V223GS-DC		THIRD ANGLE PROJECTION	
DRAWN BY PBS	DATE 9-18-13	CHK	SCALE NONE
SHT 1 OF 2		SIZE A	

THIS COPY IS PROVIDED ON A RESTRICTED BASIS AND IS NOT TO BE USED IN ANY WAY DETRIMENTAL TO THE INTERESTS OF PANDUIT CORP.

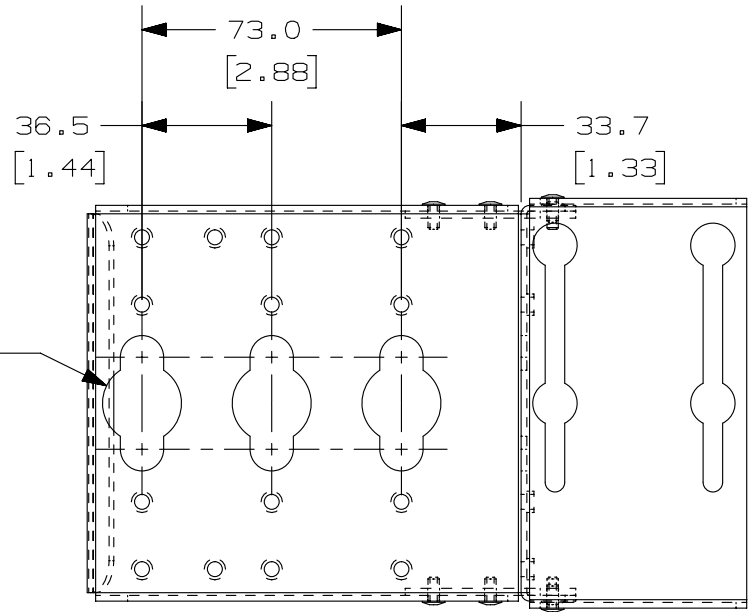
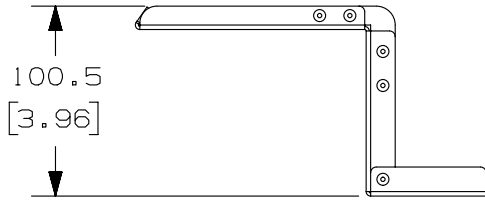

3X 22.2 DIA
[.88]

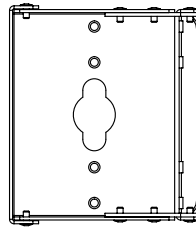
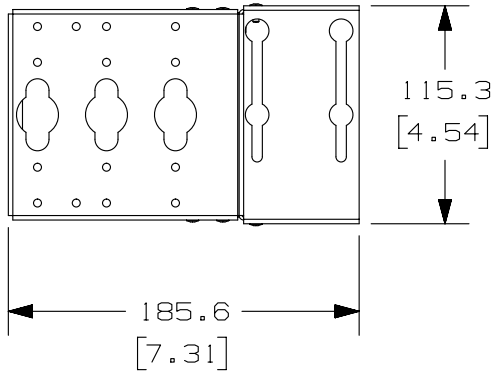

OOA	9-18-13	PBS			SEE SHEET 1 OF 2 FOR REVISIONS					11V223GS-DC		
REV	DATE	BY	CHK	APR	DESCRIPTION	ECN	DRAWN BY	DATE	CHK	SCALE	DRAWING NUMBER	SIZE
							PBS	9-18-13		NONE	SHT 2 OF 2	A

TITLE
NVPDUB NET ACCESS N-TYPE POU BRACKET FG
 CUSTOMER DRAWING

ITEM REVISION NAME
 11V223GS/00.PRT

DATASET FILE NAME
 11V223GS_DC/00A.PRT

UNLESS OTHERWISE SPECIFIED, DIMENSIONAL TOLERANCES ARE:

INCHES	METRIC - MILLIMETER	ANGLE
X.X +/- 0.06	X.X +/- 1.5	+/- 1°
X.XX +/- 0.03	X.X +/- 0.8	
X.XXX +/- 0.015	X.XX +/- 0.4	

MATERIAL/COLOR:

DRAWING NUMBER:
11V223GS-DC

THIRD ANGLE PROJECTION

DRAWN BY: PBS | DATE: 9-18-13 | CHK: | SCALE: NONE

SIZE: A

2

1

2

1