



Chipsmall Limited consists of a professional team with an average of over 10 year of expertise in the distribution of electronic components. Based in Hongkong, we have already established firm and mutual-benefit business relationships with customers from,Europe,America and south Asia,supplying obsolete and hard-to-find components to meet their specific needs.

With the principle of “Quality Parts,Customers Priority,Honest Operation,and Considerate Service”,our business mainly focus on the distribution of electronic components. Line cards we deal with include Microchip,ALPS,ROHM,Xilinx,Pulse,ON,Everlight and Freescale. Main products comprise IC,Modules,Potentiometer,IC Socket,Relay,Connector.Our parts cover such applications as commercial,industrial, and automotives areas.

We are looking forward to setting up business relationship with you and hope to provide you with the best service and solution. Let us make a better world for our industry!



Contact us

Tel: +86-755-8981 8866 Fax: +86-755-8427 6832

Email & Skype: info@chipsmall.com Web: www.chipsmall.com

Address: A1208, Overseas Decoration Building, #122 Zhenhua RD., Futian, Shenzhen, China



1A SYNCHRONOUS BUCK SWITCHER WITH FET ON BOARD

Production Datasheet

Pb Free Product
DESCRIPTION

The NX4108-33 is a current mode PWM buck switcher with internal compensation and fixed 3.3V output voltage, can provide up to 1A output current with FET on board. Switching frequency is fixed 1MHz, small surface mount inductors and capacitors are allowed to use, make it good for portable applications.

NX4108-33 is available in 5-pin SOT23 package.

- 5V Input Voltage
- Fixed 3.3V Output Voltage
- 5-pin SOT23 Package
- 1MHz Fixed Frequency PWM Operation
- Internally Compensated Current Mode Controller
- Peak Current Limit with HICCUP Feature and Over Temperature Protection
- Pre-bias Start-up Operation
- Pb-free and RoHS Compliant

FEATURES
APPLICATIONS

- Li-Ion Battery Operated Portable System
- Cellular Phones
- Portable Applications
- USB Devices

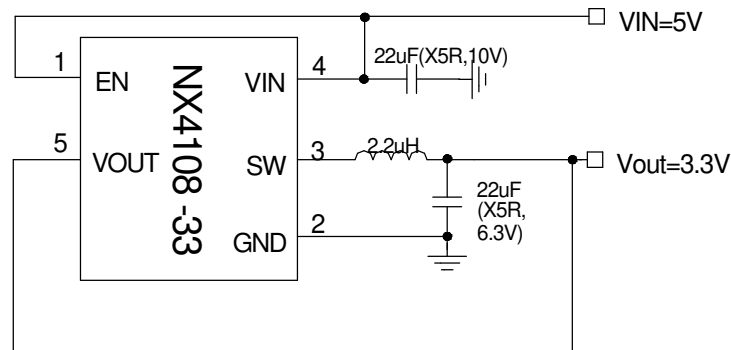
TYPICAL APPLICATION


Figure1 - Typical application of NX4108-33

ORDERING INFORMATION

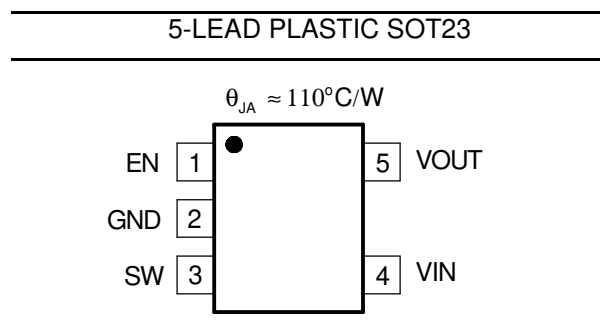
Device	Temperature	Package	Pb-Free
NX4108-33 CZ1TR	-40°C to 85°C	SOT23-5L	Yes

ABSOLUTE MAXIMUM RATINGS

V _{IN} to GND	-0.3V to 6V
SW,V _{OUT} ,EN to GND	-0.3V to V _{IN} + 0.3V
ESD Susceptibility	500V
Lead Temperature(Soldering,10sec.)	300°C
Storage Temperature Range	-55°C to 150°C
Operating Junction Temperature Range	-40°C to 150°C

CAUTION: Stresses above those listed in "ABSOLUTE MAXIMUM RATINGS", may cause permanent damage to the device. This is a stress only rating and operation of the device at these or any other conditions above those indicated in the operational sections of this specification is not implied.

PACKAGE INFORMATION



ELECTRICAL SPECIFICATIONS

V_{IN}=V_{EN}=5V, T_A= 25°C, unless otherwise specified.

PARAMETER	SYM	Test Condition	Min	TYP	MAX	Units
V_{OUT} Voltage						
V _{OUT} Voltage	V _{OUT}		3.185	3.3	3.378	V
Line Regulation						
Line Regulation		V _{IN} =4.5V to 5.5V, I _{OUT} =10mA		6	10	mV
V_{IN} UVLO						
V _{IN} Rising Threshold			2.3	2.5	2.8	V
V _{IN} Falling Threshold				2.3		V
Supply Voltage(V_{IN})						
V _{IN} Input Voltage Range	V _{IN}		4.5	5	5.5	V
Shutdown Current	I _{shutdown}	EN=GND		1	5	uA
Quiescent Current	I _q	No Load, switching		20		mA
Oscillator (Rt)						
Frequency	F _S		849	1000	1185	kHz
Max Duty Cycle			78	85		%
SS						
Soft Start Time	T _{ss}	No load	500			uS
Current Limit						
Current Limit Threshold				1.8		A

PARAMETER	SYM	Test Condition	Min	TYP	MAX	Units
Internal Switch						
Rdson of Control FET				400		mohm
Rdson of Synchronous FET				300		mohm
Enable						
En low Threshold voltage					0.4	V
En high Threshold voltage			1.4			V
Thermal Shutdown						
Thermal shutdown trip point				155		°C
Hysteresis				15		°C

PIN DESCRIPTIONS

PIN SYMBOL	PIN DESCRIPTION
SW	SW output. Junction of the internal high-side and low-side power MOSFETs, and output inductor.
GND	Ground Connection for Chip. Connect GND with large copper areas to the input and output supply returns, and negative terminals of the input and output capacitors.
VOUT	Sense output voltage .
VIN	Supply voltage input for switcher.
EN	Enable input. Set this pin to GND or less than 0.4V will shut down the regulator. Enable signal can not be high when VIN is low.

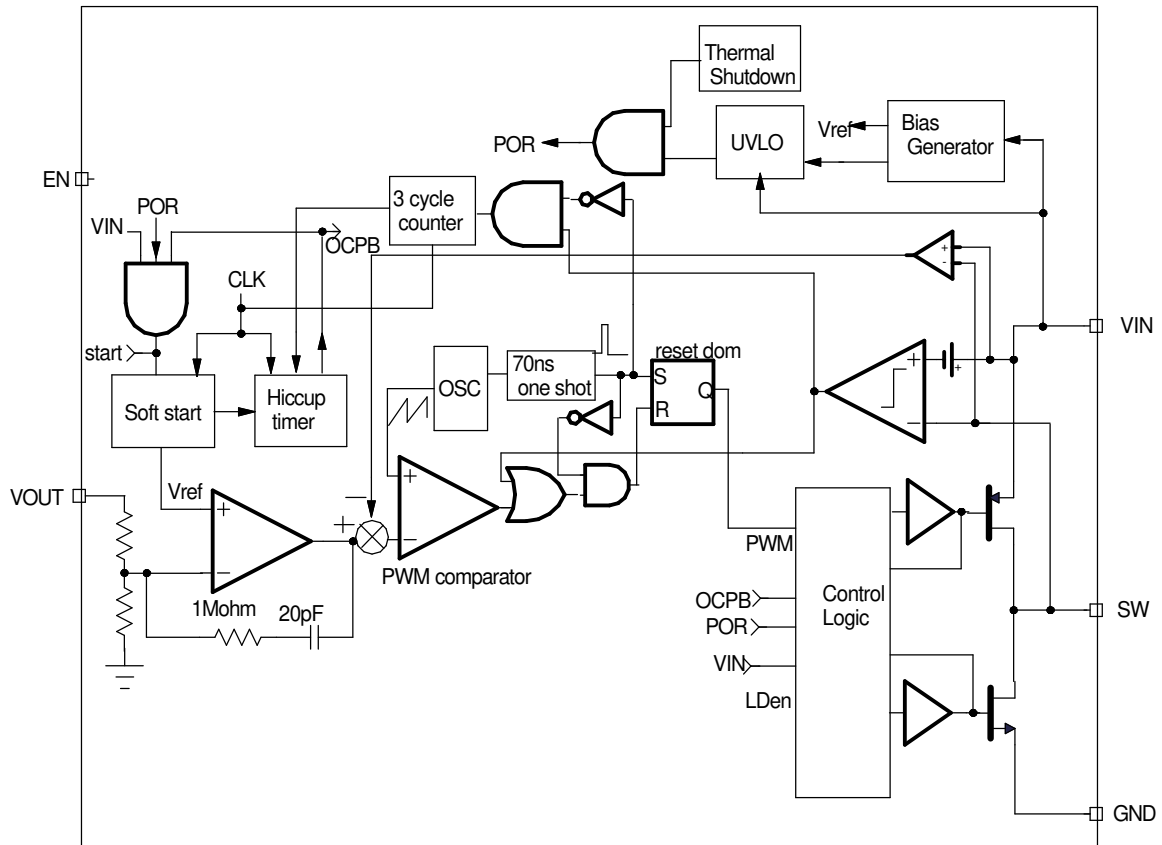
BLOCK DIAGRAM


Figure 2 - Simplified block diagram of the NX4108-33

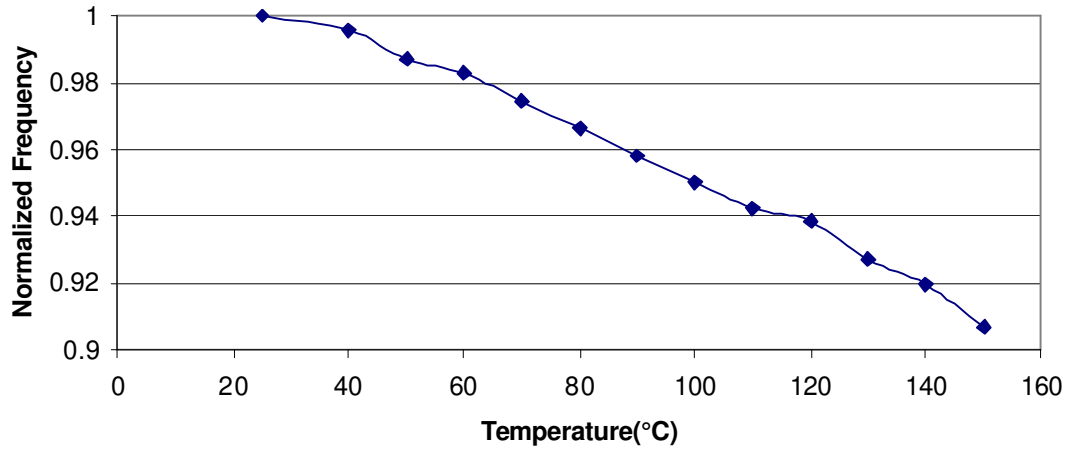
Typical Operating Characteristics**Normalized Frequency vs Temperature**

Fig.3- Normalized frequency vs temperature

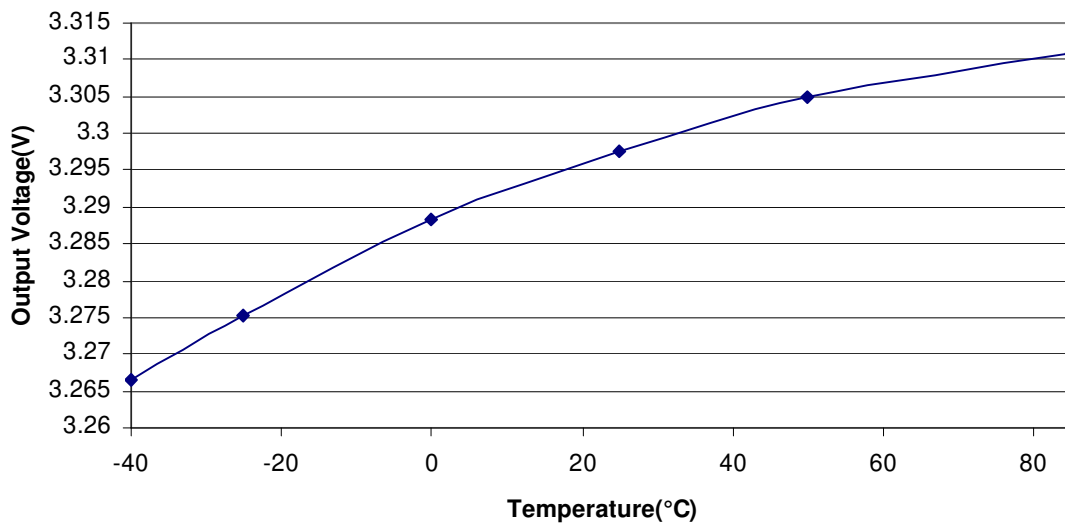
Output Voltage vs. Temperature

Fig.4- Output voltage vs temperature (VIN=5V, NO LOAD)

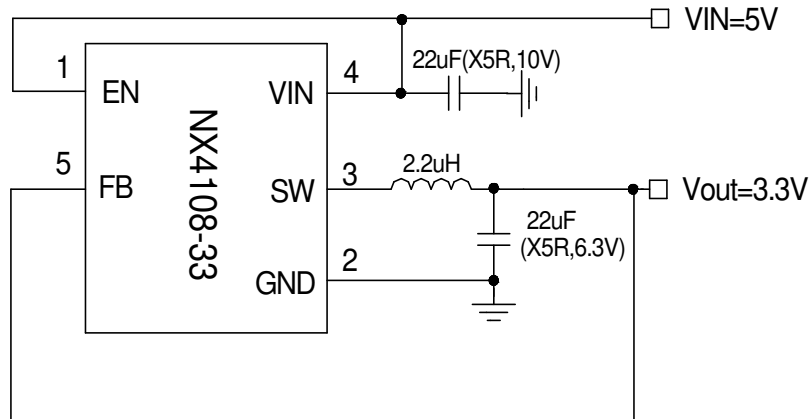
Typical Application


Figure 5 - Demo board schematic

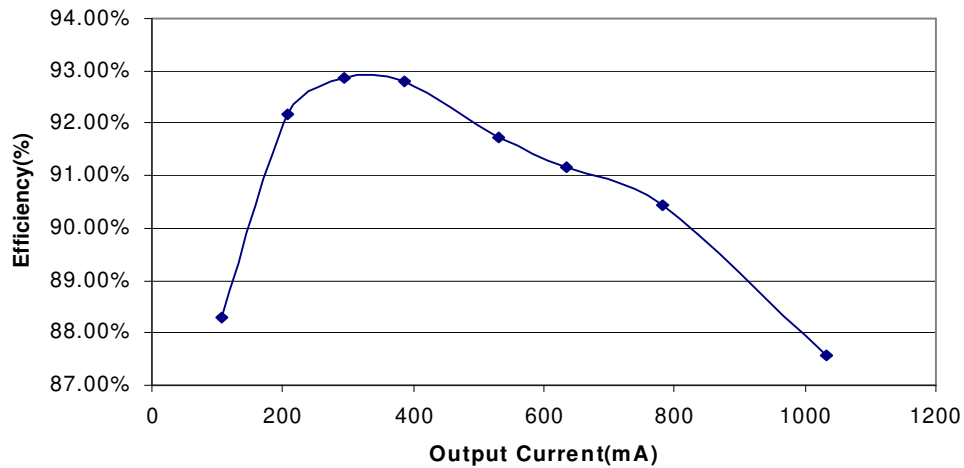
Efficiency vs. Output Current


Figure 6 - Efficiency

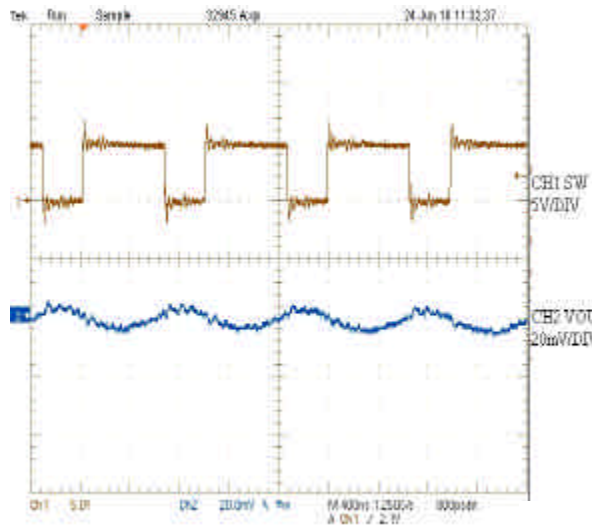
Demoboard waveforms


Figure 7 - Output ripple

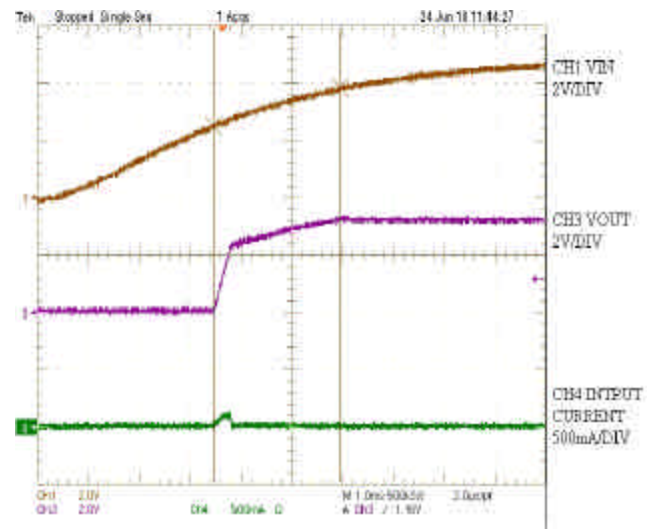


Figure 8 - Startup

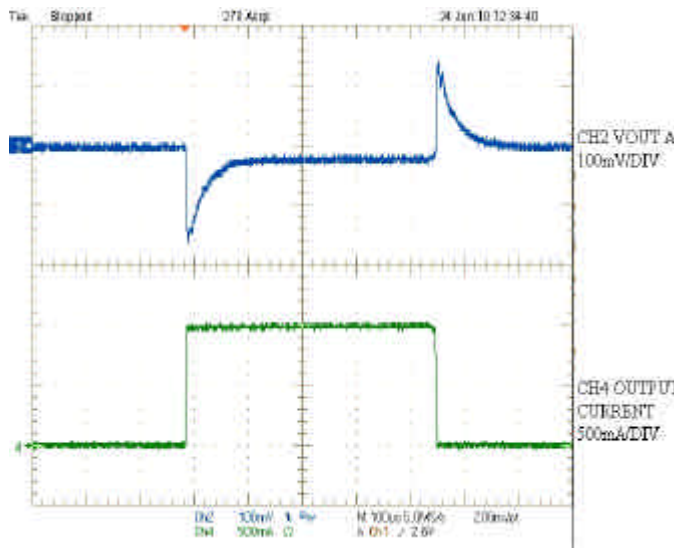


Figure 9 - Transient response

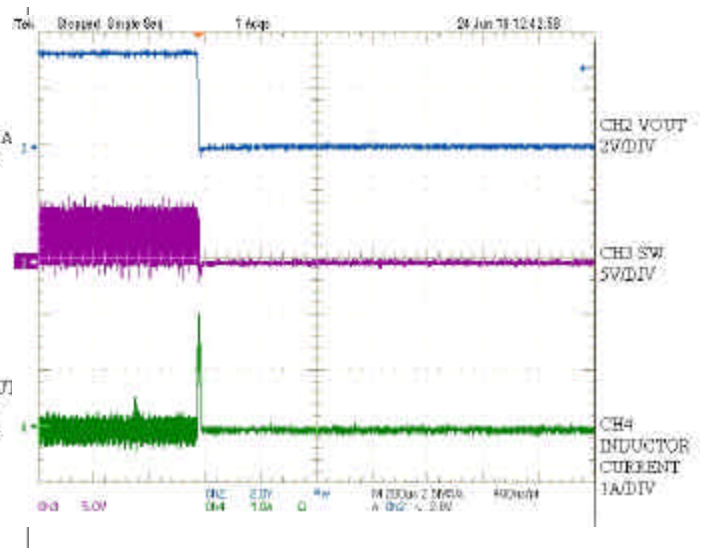
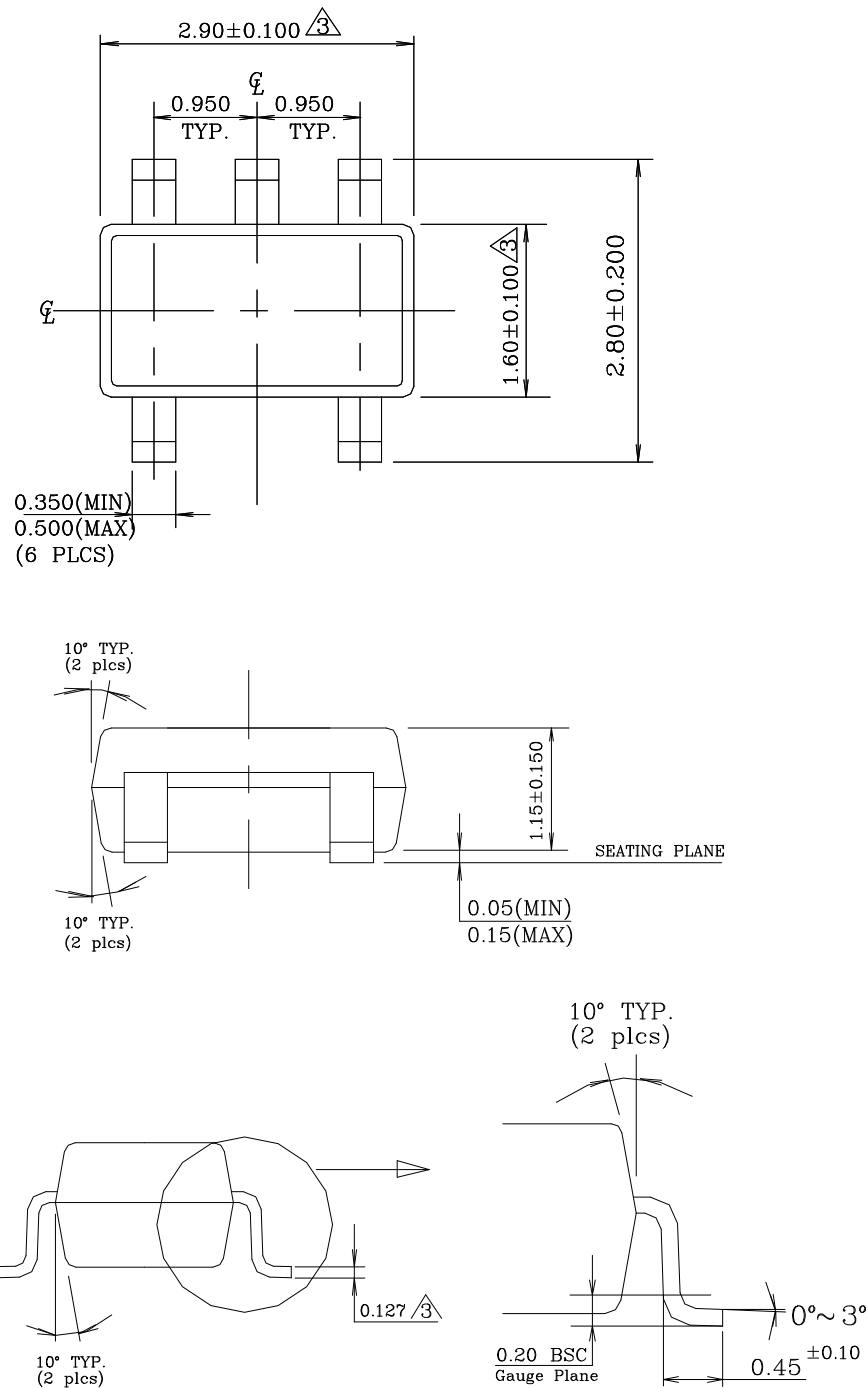



Figure 10 - Output short

SOT23-5 Outline Dimensions



NOTE:

1. Dimensions and tolerances are as per ANSI Y14.5M, 1982.
2. Package surface to be matte finish VDI 11~13.

 Dimensions are exclusive of mold flash and gate burr.