



Chipsmall Limited consists of a professional team with an average of over 10 year of expertise in the distribution of electronic components. Based in Hongkong, we have already established firm and mutual-benefit business relationships with customers from,Europe,America and south Asia,supplying obsolete and hard-to-find components to meet their specific needs.

With the principle of "Quality Parts,Customers Priority,Honest Operation,and Considerate Service",our business mainly focus on the distribution of electronic components. Line cards we deal with include Microchip,ALPS,ROHM,Xilinx,Pulse,ON,Everlight and Freescale. Main products comprise IC,Modules,Potentiometer,IC Socket,Relay,Connector.Our parts cover such applications as commercial,industrial, and automotives areas.

We are looking forward to setting up business relationship with you and hope to provide you with the best service and solution. Let us make a better world for our industry!



Contact us

Tel: +86-755-8981 8866 Fax: +86-755-8427 6832

Email & Skype: info@chipsmall.com Web: www.chipsmall.com

Address: A1208, Overseas Decoration Building, #122 Zhenhua RD., Futian, Shenzhen, China



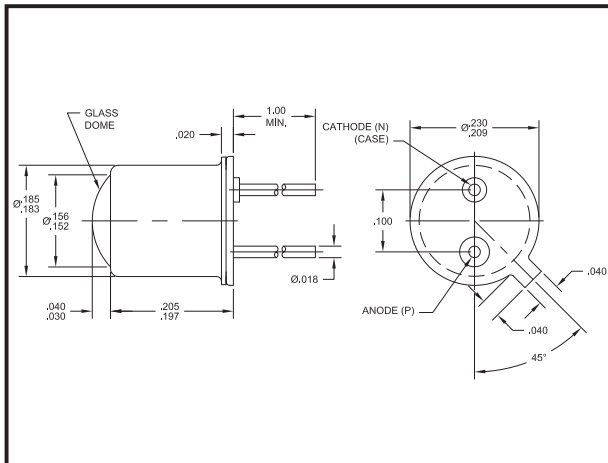

FEATURES

- High optical output
- 850nm peak emission
- Hermetically sealed TO-46 package
- Narrow angle for long distance applications

All surfaces are gold plated. Dimensions are nominal values in inches unless otherwise specified. Caps are welded to the case.



ELECTRO-OPTICAL CHARACTERISTICS AT 25°C

PARAMETERS	TEST CONDITIONS	MIN	TYP	MAX	UNITS
Total Power Output, P _O	I _F = 100mA	22	30		mW
Peak Emission Wavelength, λ _P	I _F = 20mA		850		nm
Spectral Bandwidth at 50%, Δλ	I _F = 20mA		40		nm
Half Intensity Beam Angle, θ	I _F = 20mA		8		Deg
Forward Voltage, V _F	I _F = 100mA		1.6	2	Volts
Reverse Breakdown Voltage, V _R	I _R = 10μA	5	30		Volts
Rise Time	I _{FP} = 50mA		20		nsec
Fall Time	I _{FP} = 50mA		20		nsec

ABSOLUTE MAXIMUM RATINGS AT 25°C CASE

Power Dissipation	200mW
Continuous Forward Current	100mA
Peak Forward Current (10μs, 200Hz) ¹	300mA
Reverse Voltage	5V
Lead Soldering Temperature (1/16" from case for 10sec)	260°C

¹Derate linearly above 25°C.

THERMAL PARAMETERS

Storage and Operating Temperature Range	-40°C to 100°C
Maximum Junction Temperature	100°C
Thermal Resistance, R _{THJA} ¹	400°C/W Typical
Thermal Resistance, R _{THJA} ²	135°C/W Typical

¹Heat transfer minimized by measuring in still air with minimum heat conducting through leads.

²Air circulating at a rapid rate to keep case temperature at 25°C.



750 Mitchell Road, Newbury Park, California 91320
 Phone: (805) 499-0335, Fax: (805) 499-8108
 Email: sales@optodiode.com, Website: www.optodiode.com

MAXIMUM RATINGS

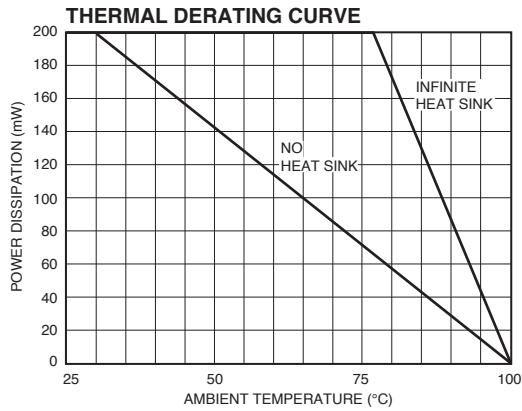

TYPICAL CHARACTERISTICS

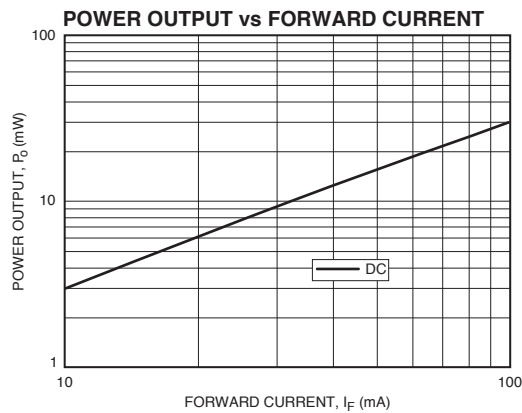
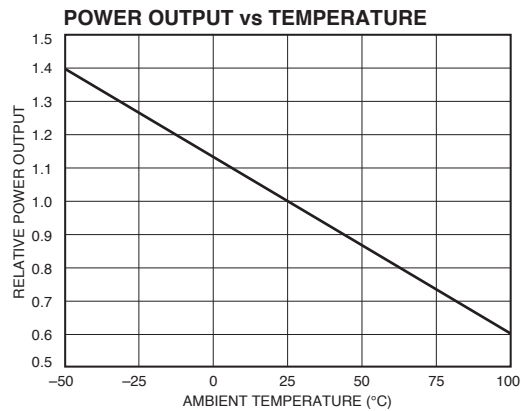
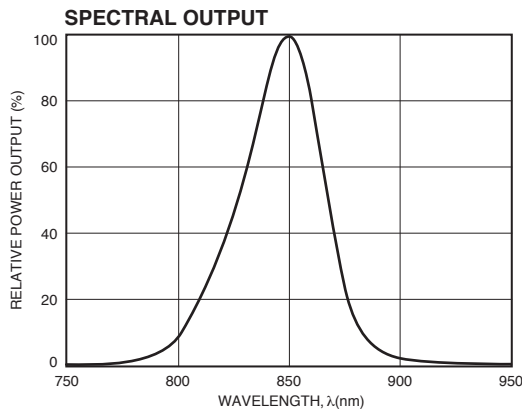
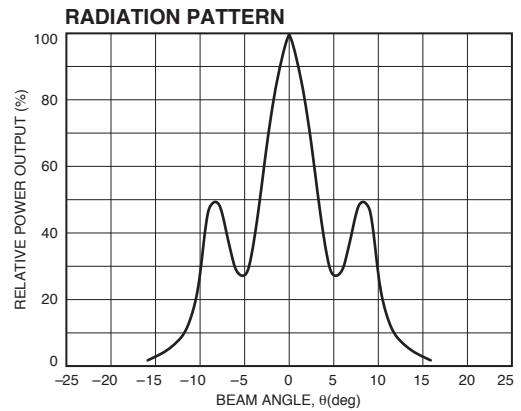
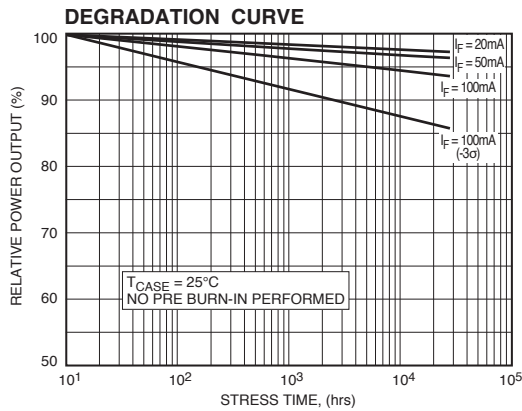

750 Mitchell Road, Newbury Park, California 91320
 Phone: (805) 499-0335, Fax: (805) 499-8108
 Email: sales@optodiode.com, Website: www.optodiode.com