



Chipsmall Limited consists of a professional team with an average of over 10 year of expertise in the distribution of electronic components. Based in Hongkong, we have already established firm and mutual-benefit business relationships with customers from,Europe,America and south Asia,supplying obsolete and hard-to-find components to meet their specific needs.

With the principle of “Quality Parts,Customers Priority,Honest Operation,and Considerate Service”,our business mainly focus on the distribution of electronic components. Line cards we deal with include Microchip,ALPS,ROHM,Xilinx,Pulse,ON,Everlight and Freescale. Main products comprise IC,Modules,Potentiometer,IC Socket,Relay,Connector.Our parts cover such applications as commercial,industrial, and automotives areas.

We are looking forward to setting up business relationship with you and hope to provide you with the best service and solution. Let us make a better world for our industry!



## Contact us

Tel: +86-755-8981 8866 Fax: +86-755-8427 6832

Email & Skype: info@chipsmall.com Web: www.chipsmall.com

Address: A1208, Overseas Decoration Building, #122 Zhenhua RD., Futian, Shenzhen, China



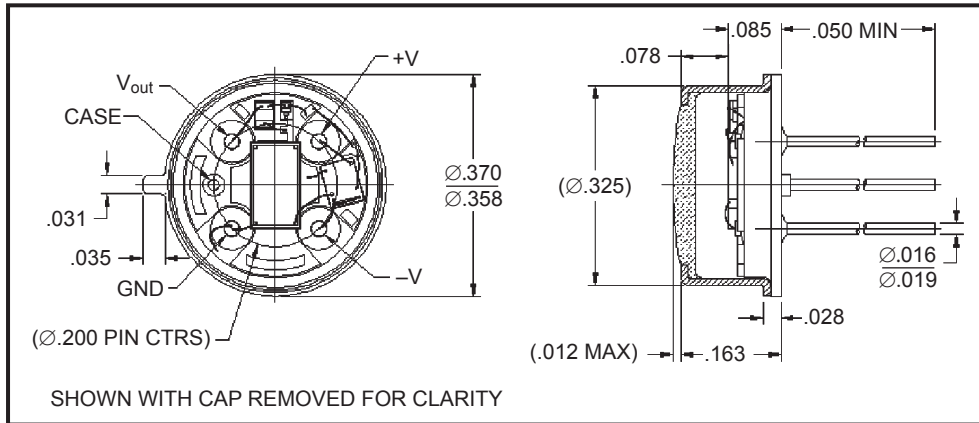

**FEATURES**

- Large active area
- Low noise
- High sensitivity
- Custom gains available
- Hermetically sealed TO-39
- Blue enhanced detector

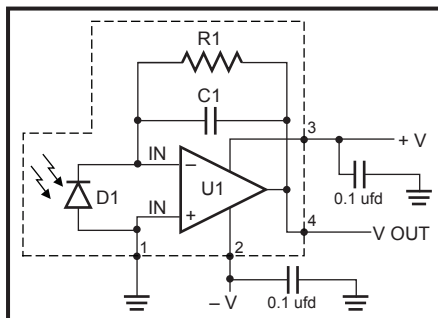

**ELECTRO-OPTICAL CHARACTERISTICS AT 23°C**

PARAMETERS	TEST CONDITIONS	MIN	TYP	MAX	UNITS
Dark Offset	$V_s = \pm 5 V$		1.2	$\pm 2$	mV
Dark Offset Noise	$V_s = \pm 5$ BW = 0.1 to 1000 Hz		198	250	$\mu V$ rms
Sensitivity	$V_s = \pm 5 V$ $\lambda = 450 \text{ nm}$	20	28		$V/\mu W$
Frequency Response (-3 db)	$V_s = \pm 5 V$ $\lambda = 940 \text{ nm}$	900	1000		Hz
NEP	$\lambda = 940 \text{ nm}$		0.08		$pW/\sqrt{Hz}$
Transimpedance Gain			100		$M\Omega$
Supply Current			850	950	$\mu A$

**THERMAL PARAMETERS**

Voltage Supplies	$\pm 5$ to $\pm 15V$
Power Dissipation	30 mW
Storage and Operating Temperature	$-25^\circ$ to $+100^\circ C$
Soldering Temperature (1/16" from case for 3 seconds max)	$+260^\circ C$



750 Mitchell Road, Newbury Park, California 91320  
 Phone: (805) 499-0335, Fax: (805) 499-8108  
 Email: sales@optodiode.com, Website: www.optodiode.com

