



Chipsmall Limited consists of a professional team with an average of over 10 year of expertise in the distribution of electronic components. Based in Hongkong, we have already established firm and mutual-benefit business relationships with customers from,Europe,America and south Asia,supplying obsolete and hard-to-find components to meet their specific needs.

With the principle of “Quality Parts,Customers Priority,Honest Operation,and Considerate Service”,our business mainly focus on the distribution of electronic components. Line cards we deal with include Microchip,ALPS,ROHM,Xilinx,Pulse,ON,Everlight and Freescale. Main products comprise IC,Modules,Potentiometer,IC Socket,Relay,Connector.Our parts cover such applications as commercial,industrial, and automotives areas.

We are looking forward to setting up business relationship with you and hope to provide you with the best service and solution. Let us make a better world for our industry!



Contact us

Tel: +86-755-8981 8866 Fax: +86-755-8427 6832

Email & Skype: info@chipsmall.com Web: www.chipsmall.com

Address: A1208, Overseas Decoration Building, #122 Zhenhua RD., Futian, Shenzhen, China



DATA SHEET

OLS449: Radiation-Tolerant Phototransistor Hermetic Surface-Mount Optocoupler

Features

- Radiation tolerant version of the 4N49U
- High current transfer ratio (CTR) is guaranteed:
 - Over $-55\text{ }^{\circ}\text{C}$ to $+125\text{ }^{\circ}\text{C}$ ambient temperature range
 - At LED current of 1mA
- 1000 V_{DC} electrical isolation
- Same reliable processing and construction as the OLS249, but with a higher CTR
- High-reliability screenings are available

Description

The OLS449 is specifically designed for high reliability and space applications that require optical isolation in radiation environments such as gamma, neutron, and proton radiation with a high CTR and low saturation V_{CE}. Each optocoupler consists of an LED and N-P-N silicon phototransistor that is electrically isolated, but optically coupled inside a hermetic six-pin Leadless Chip Carrier (LCC) package.

Electrical parameters are similar to the JEDEC registered 4N49 optocoupler, but with a higher CTR and better CTR degradation characteristics due to radiation exposure.

The OLS449 is designed for a low LED operating current while providing excellent radiation tolerance margins. The OLS449 has 100 percent high-reliability screenings available.

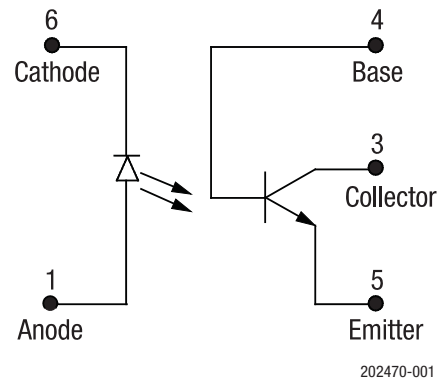

Figure 1. OLS449 Block Diagram

A functional block diagram of the OLS449 is shown in Figure 1. The absolute maximum ratings of the OLS449 are provided in Table 1. Electrical specifications are provided in Table 2.

Typical performance characteristics of the OLS449 are illustrated in Figures 2 through 4. A typical switching test circuit is shown in Figure 5 and package dimensions for the OLS449 are provided in Figure 6.

Table 1. OLS449 Absolute Maximum Ratings¹

Parameter	Symbol	Minimum	Maximum	Units
<i>Coupled</i>				
Input to output isolation voltage ²	V _{OC}	-1000	+1000	V
Storage temperature range	T _{STG}	-65	+150	°C
Operating temperature range	T _A	-55	+125	°C
Lead temperature range for 10 sec			240	°C
<i>Input Diode</i>				
Average input current	I _{DD}		40	mA
Peak forward current ³	I _F		1	A
Reverse voltage	V _R		2	V
Power dissipation	P _D		70	mW
<i>Output Detector</i>				
Collector to emitter voltage	V _{CE}		65	V
Emitter to base voltage	V _{EB}		7	V
Collector to base voltage	V _{CB}		65	V
Continuous collector current	I _{CC}		50	mA
Power dissipation ⁴	P _D		300	mW

¹ Exposure to maximum rating conditions for extended periods may reduce device reliability. There is no damage to device with only one parameter set at the limit and all other parameters set at or below their nominal value. Exceeding any of the limits listed here may result in permanent damage to the device.

² Measured between pins 1, 2, and 6 shorted together, and pins 3, 4, and 5 shorted together. T_A = 25 °C and duration = 1 s.

³ Value applies for P_w ≤ 1 μs, PRR ≤ 300 pps.

⁴ Derate linearly at 3 mW/°C above 25 °C.

ESD HANDLING: *Although this device is designed to be as robust as possible, electrostatic discharge (ESD) can damage this device. This device must be protected at all times from ESD when handling or transporting. Static charges may easily produce potentials of several kilovolts on the human body or equipment, which can discharge without detection. Industry-standard ESD handling precautions should be used at all times.*

Table 2. OLS449 Electrical Specifications¹
(T_A = 25 °C, Unless Otherwise Noted)

Parameter	Symbol	Test Condition	Min	Max	Units
On-State:					
Collector current	I _{C_ON}	I _F = 1 mA, V _{CE} = 5 V	15	40	mA
		I _F = +1 mA, V _{CE} = +5 V, T _A = -55 °C	+7		mA
		I _F = 1 mA, V _{CE} = 5 V, T _A = 125 °C	7		mA
Collector to base current	I _{CB_ON}	I _F = 10 mA, V _{CB} = 5 V	300		μA
Saturation voltage	V _{CE_SAT}	I _F = 1.0 mA, I _C = 5.0 mA		0.3	V
Breakdown voltage:					
Collector to emitter	BV _{CEO}	I _{CE} = 1 mA	65		V
Collector to base	BV _{CBO}	I _{CB} = 100 μA	65		V
Emitter to base	BV _{EBO}	I _{EB} = 100 μA	7		V
Off-state leakage current:					
Collector to emitter	I _{CE_OFF}	V _{CE} = 20 V		100	nA
		V _{CE} = 20 V, T _A = 125 °C		100	μA
Collector to base	I _{CB_OFF}	V _{CB} = 20 V		10	nA
Input:					
Forward voltage	V _F	I _F = +10.0 mA, T _A = -55 °C	+1.3	+1.9	V
		I _F = 10.0 mA	1.2	1.7	V
		I _F = 10.0 mA, T _A = 125 °C	1.1	1.6	V
Reverse current	I _R	V _R = 2 V		100	μA
Output resistance ²	R _{L_0}	V _{L_0} = ±1000 V _{DC}	10 ¹¹		Ω
Output capacitance ²	C _{L_0}	V _{L_0} = 0 V, f = 1 MHz		5	pF
Time:					
Rise	t _r	V _{CC} = 10 V, R _L = 100 Ω		25	μs
Fall	t _f	I _F = 5 mA		25	μs

¹ Performance is guaranteed only under the conditions listed in the above table.

² Measured between pins 1, 2, and 6 shorted together, and pins 3, 4, and 5 shorted together. T_A = 25 °C and duration = 1 s.

Typical Performance Characteristics
 ($T_A = -55\text{ }^\circ\text{C}$ to $+125\text{ }^\circ\text{C}$, Unless Otherwise Noted)

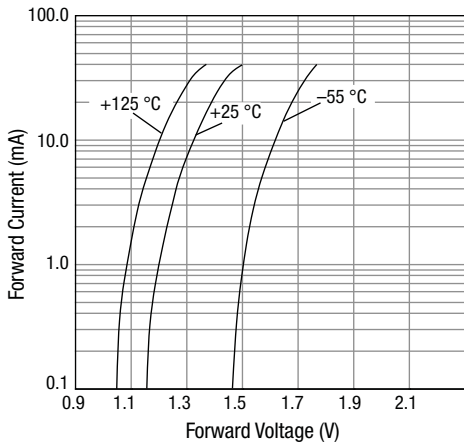

Figure 2. Forward Current vs Forward Voltage

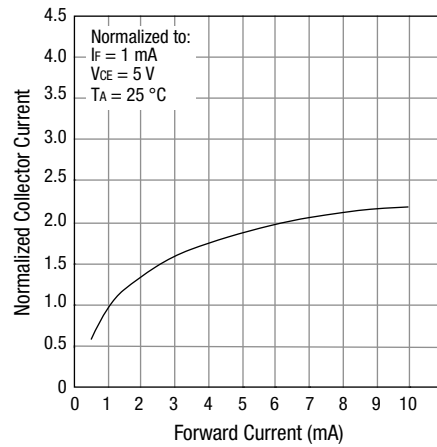

Figure 3. Normalized Collector Current vs Forward Current

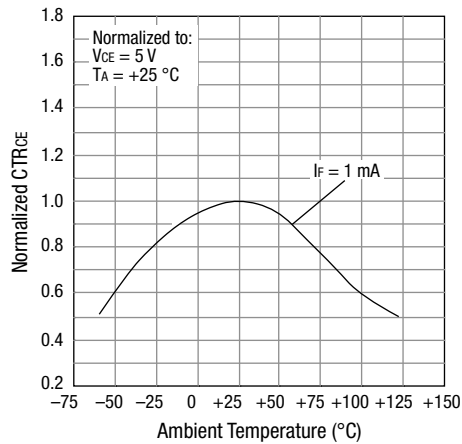

Figure 4. Normalized CTR_{CE} vs Temperature

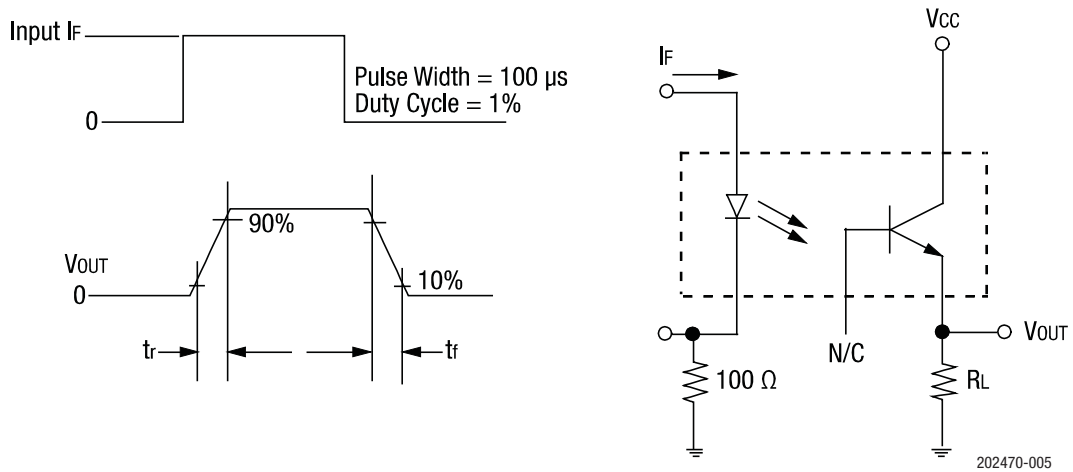

Figure 5. OLS449 Switching Test Circuit

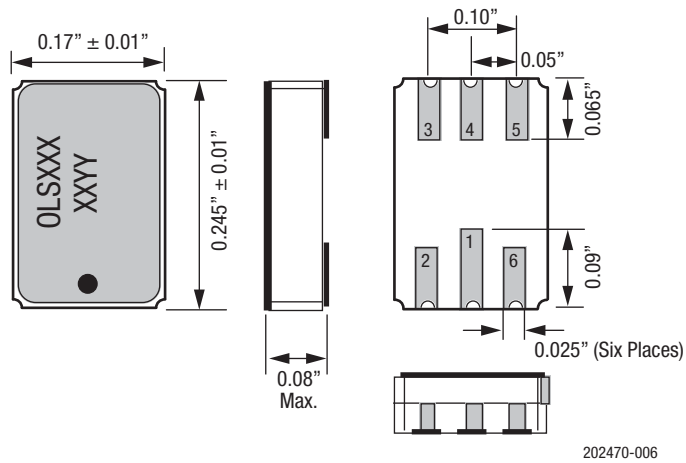

Figure 6. OLS449 Package Dimensions

Ordering Information

Model Name	Manufacturing Part Number
OLS449: Radiation-Tolerant, Phototransistor Hermetic Surface-Mount Optocoupler	OLS449

Copyright © 2012-2015, 2017 Isolink, Inc. All Rights Reserved.

Information in this document is provided in connection with Isolink, Inc. ("Isolink"), a wholly-owned subsidiary of Skyworks Solutions, Inc. These materials, including the information contained herein, are provided by Isolink as a service to its customers and may be used for informational purposes only by the customer. Isolink assumes no responsibility for errors or omissions in these materials or the information contained herein. Isolink may change its documentation, products, services, specifications or product descriptions at any time, without notice. Isolink makes no commitment to update the materials or information and shall have no responsibility whatsoever for conflicts, incompatibilities, or other difficulties arising from any future changes.

No license, whether express, implied, by estoppel or otherwise, is granted to any intellectual property rights by this document. Isolink assumes no liability for any materials, products or information provided hereunder, including the sale, distribution, reproduction or use of Isolink products, information or materials, except as may be provided in Isolink Terms and Conditions of Sale.

THE MATERIALS, PRODUCTS AND INFORMATION ARE PROVIDED "AS IS" WITHOUT WARRANTY OF ANY KIND, WHETHER EXPRESS, IMPLIED, STATUTORY, OR OTHERWISE, INCLUDING FITNESS FOR A PARTICULAR PURPOSE OR USE, MERCHANTABILITY, PERFORMANCE, QUALITY OR NON-INFRINGEMENT OF ANY INTELLECTUAL PROPERTY RIGHT; ALL SUCH WARRANTIES ARE HEREBY EXPRESSLY DISCLAIMED. ISOLINK DOES NOT WARRANT THE ACCURACY OR COMPLETENESS OF THE INFORMATION, TEXT, GRAPHICS OR OTHER ITEMS CONTAINED WITHIN THESE MATERIALS. ISOLINK SHALL NOT BE LIABLE FOR ANY DAMAGES, INCLUDING BUT NOT LIMITED TO ANY SPECIAL, INDIRECT, INCIDENTAL, STATUTORY, OR CONSEQUENTIAL DAMAGES, INCLUDING WITHOUT LIMITATION, LOST REVENUES OR LOST PROFITS THAT MAY RESULT FROM THE USE OF THE MATERIALS OR INFORMATION, WHETHER OR NOT THE RECIPIENT OF MATERIALS HAS BEEN ADVISED OF THE POSSIBILITY OF SUCH DAMAGE.

Customers are responsible for their products and applications using Isolink products, which may deviate from published specifications as a result of design defects, errors, or operation of products outside of published parameters or design specifications. Customers should include design and operating safeguards to minimize these and other risks. Isolink assumes no liability for applications assistance, customer product design, or damage to any equipment resulting from the use of Isolink products outside of stated published specifications or parameters.

Isolink is a trademark of Isolink Inc. in the United States and other countries. Skyworks and the Skyworks symbol are trademarks or registered trademarks of Skyworks Solutions, Inc., in the United States and other countries. Third-party brands and names are for identification purposes only, and are the property of their respective owners.