



Chipsmall Limited consists of a professional team with an average of over 10 year of expertise in the distribution of electronic components. Based in Hongkong, we have already established firm and mutual-benefit business relationships with customers from,Europe,America and south Asia,supplying obsolete and hard-to-find components to meet their specific needs.

With the principle of “Quality Parts,Customers Priority,Honest Operation,and Considerate Service”,our business mainly focus on the distribution of electronic components. Line cards we deal with include Microchip,ALPS,ROHM,Xilinx,Pulse,ON,Everlight and Freescale. Main products comprise IC,Modules,Potentiometer,IC Socket,Relay,Connector.Our parts cover such applications as commercial,industrial, and automotives areas.

We are looking forward to setting up business relationship with you and hope to provide you with the best service and solution. Let us make a better world for our industry!



## Contact us

Tel: +86-755-8981 8866 Fax: +86-755-8427 6832

Email & Skype: info@chipsmall.com Web: www.chipsmall.com

Address: A1208, Overseas Decoration Building, #122 Zhenhua RD., Futian, Shenzhen, China



# UM10370

## User Manual for the PCF8883 Evaluation Kit OM11055

Rev. 02 — 2 December 2009

User manual

### Document information

Info	Content
<b>Keywords</b>	Capacitive switch, sensor, proximity switch, PCF8883, OM11055, PCF8883 evaluation board
<b>Abstract</b>	The OM11055 is a PCF8883 evaluation board which can be used to demonstrate and evaluate the PCF8883 capacitive proximity switch. The PCB is designed to make it easy to adjust the switch's sensitivity. The board can be powered using a Mini USB cable or a 9V battery.

**Revision history**

Rev	Date	Description
02	20091202	Fully updated version to reflect the change of the evaluation kit. Revision 1 was written for the preliminary evaluation board which was marked "MA142_EVALBOARD.BRD". Revision 2 is valid for the new evaluation kit OM11055 (not marked as such on the board).
01	20090731	Initial release

**Contact information**

For additional information, please visit: <http://www.nxp.com>

For sales office addresses, please send an email to: [salesaddresses@nxp.com](mailto:salesaddresses@nxp.com)

## 1. Introduction

---

This user manual describes the OM11055 evaluation kit. This board was developed in order to provide a tool for application engineers and development engineers wishing to try and evaluate the single channel PCF8883 capacitive proximity switch. A LED displays the status of the switch; test points facilitate measurements of important signals.

The desired capacitive sensor area can vary in terms of material, form, size and switching distance. Each particular switch configuration demands a suitable electrical circuit for the input signal. This board allows to easily change the input circuit and the two capacitors which define the sensitivity and reaction speed of the sensor in a typical application. This offers the opportunity to rapidly evaluate many possible switching configurations.

### Features:

- Simple demonstration of the single channel PCF8883 capacitive proximity switch
- Jumper to select one of the three possible switch modes of the PCF8883
- Evaluate different sensor sizes (four different sensor plates included on the board) or off board user defined sensors
- Two power supply options: via USB cable or a 9V battery
- Provisions for through-hole components allowing them to be easily changed
- Contents of the kit:
  - One PCF8883 evaluation board
  - One 3 ft USB A-B Mini Cable
- All documentation is available from the NXP website:  
<http://www.standardics.nxp.com/support/boards/pcf8883>

## 2. Quick start

---

The OM11055 is an evaluation board for the single channel PCF8883 capacitive proximity switch.

1. Apply power to the board by connecting the supplied mini USB cable to the PCF8883 board and the other end into a PC or a USB power adapter. Alternatively a 9V battery can be used. The capacitive proximity sensor is now active.
2. With no jumpers on J9 (timed mode), touching the sense plate CP1 will turn on the green output LED (LD1) for about two seconds.

Please read this manual completely for configuration options and modes.



### 3. Board description and layout

Below the top view of the board is shown.

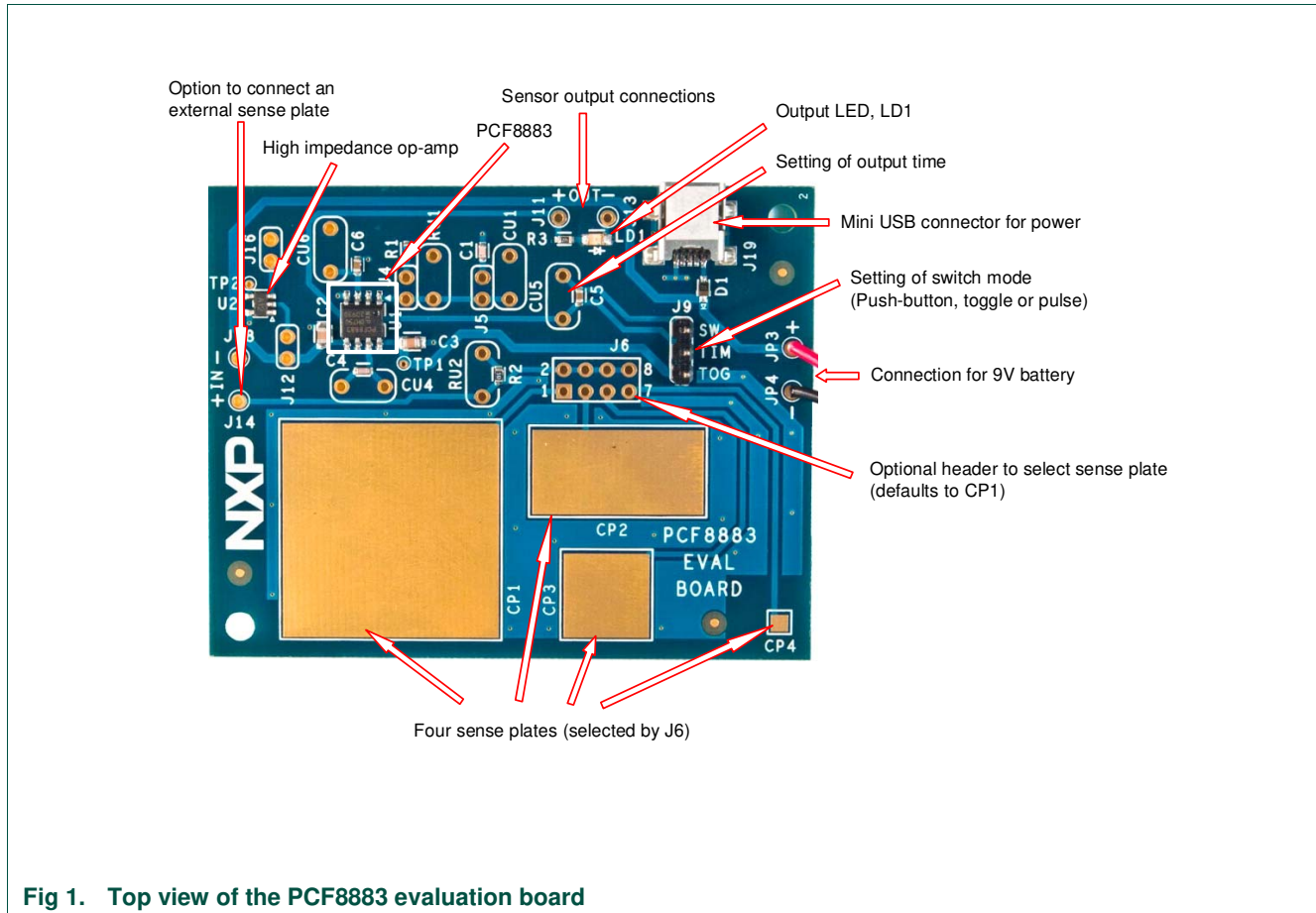

Fig 1. Top view of the PCF8883 evaluation board

The lower half is dominated by four sensor areas of different size. The actual circuit is on the upper half of the board. Arrows indicate the parts of interest which are described more in detail in subsequent sections.

#### 3.1 Setting the PCF8883 operation modes

The OM11055 allows the user to set one of three output switching behaviour modes, using jumper J9. Refer to Fig 2:

- With no jumper on J9, the PCF8883 will operate in pulse mode. The output is activated for a defined time at each capacitive event. This defined time is determined by C5.
- With the jumper across the “TOG” and “TIM” pins, the PCF8883 will operate in toggle mode (touch on, touch off).
- With the jumper across the “SW” and “TIM” pins, the PCF8883 will operate in momentary switch mode (push-button). The output is active as long as the capacitive event lasts.



Fig 2. Selection of operating mode using jumper J9

## 4. User configurable settings

The OM11055 kit allows the user to configure the PCF8883 sensor for evaluation in a specific application.

### 4.1 Sensor plate selection

The OM11055 board includes four sensor plates on the board itself and provisions to connect the PCF8883 to an external sensor. The board connects CP1 to the PCF8883 by default. To enable the other sensor options:

1. Cut the trace that shorts J6 pins 1 & 2 on the underside of the board.
2. Solder in a user supplied 8-pin header (0.1" pitch) at J6.
3. To select sensor plate CP4, connect a user-supplied jumper across J6, pins 7 & 8; to select CP3, jumper pins 5 & 6 of J6, etc.

To use an off board sensing plate, connect the plate at J14 & J18 using coax cable. The coaxial shield must be connected to the input pin which is marked '-'. In this case do not jumper any pins on J6.

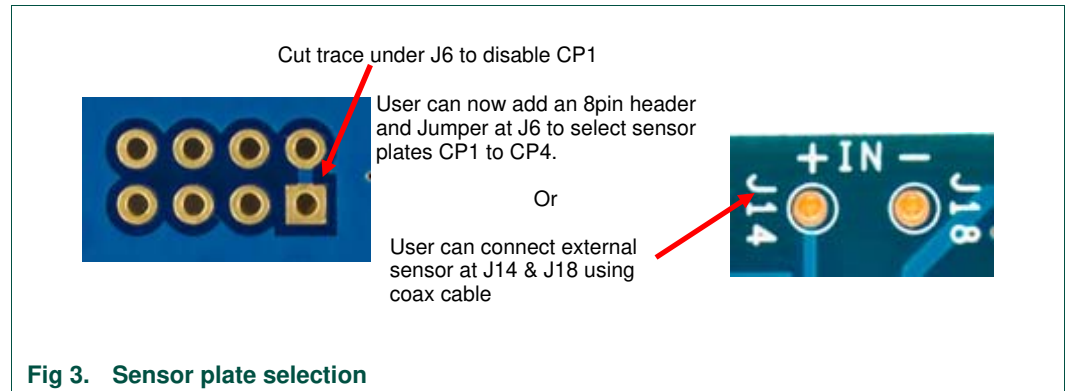
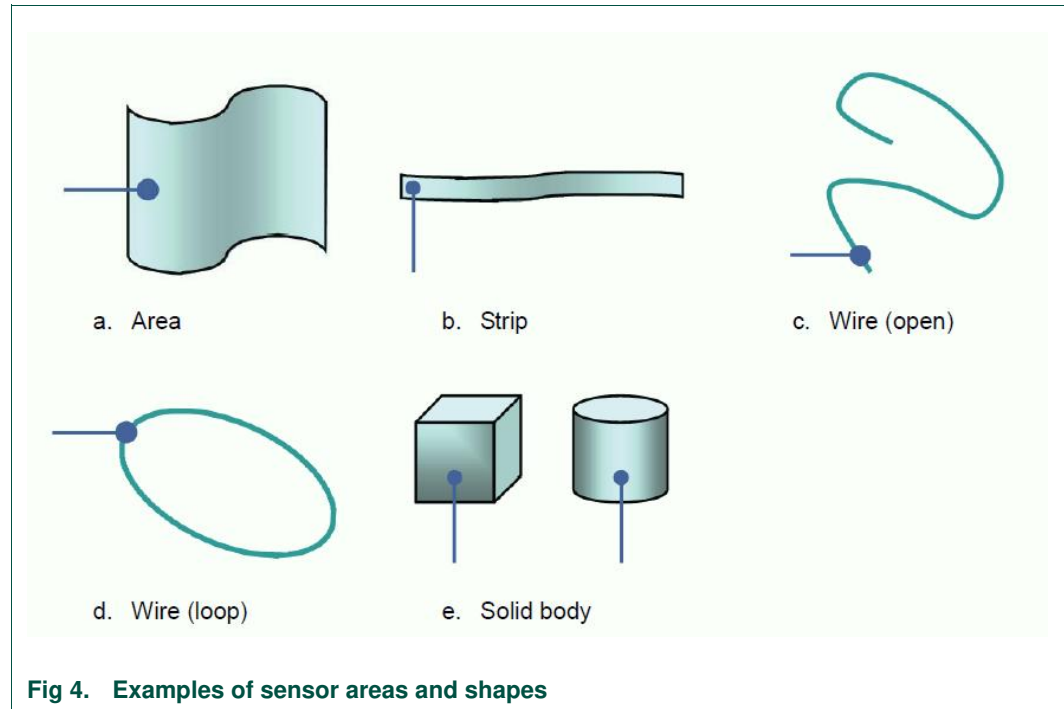

Fig 3. Sensor plate selection

The size and form of the sensor plate can be varied to obtain optimal switching behaviour or to shape the sensor for a given application.

The following figure shows some creative examples of how the switch can be used with sensors of various size and shape.



### 4.2 Sensitivity settings

The OM11055 board allows for easy modifications to the circuit to change the switch's sensitivity. It can be difficult to remove and install surface mount capacitors and resistors without damaging the board. Therefore the OM11055 board includes holes to add conventional through-hole passive components which enable quick evaluation of different values. To remove the SMD components R1 and C1 from the circuit, cut the trace shorts on the underside of the PCB at J4 and J5. Refer to the PCF8883 datasheet and the application note AN10832 for details on adjusting the sensitivity.

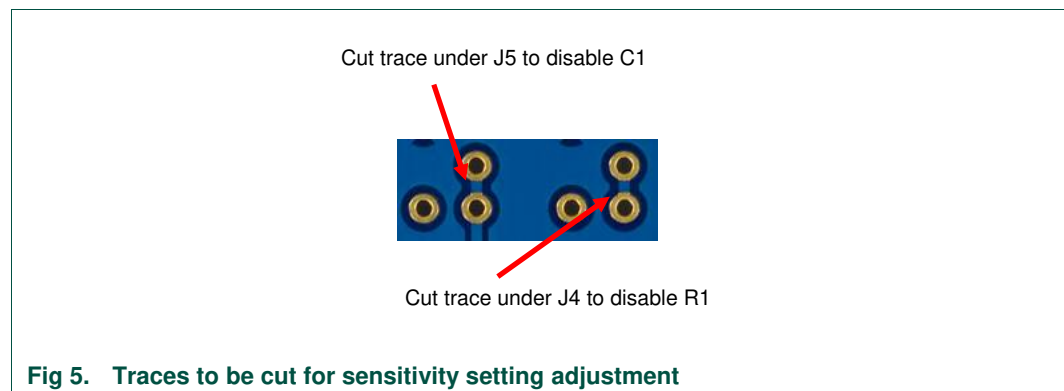

### 4.3 Power supply options

Power to the OM11055 PCB can be supplied using a mini USB cable (provided) or a 9V battery. The 9V battery connector can be removed and a user provided power supply could be connected at JP3 & JP4 for evaluation of a specific application. Using an external power supply also allows for easy measuring of the power consumption.

**Warning:** There is no protection against reverse polarity of the external power supply.

### 4.4 High impedance op-amp

A high input impedance rail-to-rail input and output op-amp (U2) is included on the board to measure the voltage at the CPC pin of the PCF8883. A capacitor is connected between pin CPC and Vss. The value of this capacitor is used to adjust the sensitivity of the switch. Since this is a very high impedance node, measuring directly with a probe would disturb the control loop. Therefore this voltage buffer has been included on the board. By default, this op-amp is not connected, as it would add to power consumption measurements. To enable U2, install two pin headers and jumpers at J12 and J16.

**Remark 1:** Always first provide power to op-amp U2 (jumper J12) before connecting the input to pin CPC of the PCF8883 (J16). Reversing this sequence could result in a CMOS latch up.

**Remark 2:** The capacitor  $C_{CPC}$  must be a good quality X7R type to minimize charge leakage.

## 5. Sensor adjustment

It is recommended to start the evaluation of the application using the pre-assembled components on the board since these have typical values and were tuned for use with the default connected sensor plate CP1. This should give an adequate response in most cases. In cases where the switch does not respond or responds unreliably, it is likely that the input capacitance exceeds the specified input range. The voltage measured on  $C_{CPC}$ , via testpoint TP2, should ideally be approximately  $\frac{1}{2} \cdot V_{DDREG}$  (note:  $\frac{1}{2} \cdot V_{DDREG}$  which is half the internally regulated supply voltage, not  $\frac{1}{2} \cdot V_{DD}$ ). The bias point can be optimized by first changing  $C_F$  (and possibly also  $R_C$ ) according to step 1 in the 5-step table below. Once the switch works properly, further optimizations can be done by adjusting  $C_{CPC}$  and  $C_{LIN}$ . Details concerning optimization of the biasing are given in application note AN10832.

The circuit has three parameters that influence the switching behaviour. These are listed below in order of their influence:

- Switch sensitivity, set by  $C_{CPC}$
- Calibration of the total capacitance on the sensor input using resistor  $R_C$  and capacitor  $C_F$
- Switching speed, set by  $C_{CLIN}$



Table 1. Optimizing step by step

Step	Component	Description	Min	Typ	Max
1	$C_{IN}$ ( $C_F$ )	$C_{IN}$ is the <b>total input capacitance</b> ( $C_{Sensor} + C_{cable} + C_F$ ). $C_F$ should be chosen such that $C_{IN}$ is about 30 pF. This can be checked by measuring the voltage over $C_{CPC}$ which should then be about $\frac{1}{2} V_{DD}$ .	10 pF	30 pF	60 pF
2	$R_S$	$R_S$ and $C_F$ form a low pass filter. The typical values are likely to be correct for most applications.	-	6.8 k $\Omega$	-
3	$R_C$	This resistance compensates large input capacitances (long coaxial cable, larger sensor plate area). Smaller resistor values should be used with larger input capacitances.	5 k $\Omega$	39 k $\Omega$	50 k $\Omega$
4	$C_{CPC}$	$C_{CPC}$ determines the <b>sensitivity</b> of the sensor. If the sensitivity is increased, the possibility of incorrect switching due to interfering electrical fields is also increased. This parameter has a strong influence on the switching characteristic.	90 nF	470 nF	2500 nF
5	$C_{CLIN}$	$C_{CLIN}$ determines the internal sampling frequency and therefore the <b>reaction time</b> of the switch. Smaller values of $C_{CLIN}$ correspond to shorter reaction times. Shorter reaction times lead to increased current consumption.	0 pF	22 pF	100 nF

## 6. Board schematic

On the next page the schematic of the Rev “A” OM11055 PCB is shown. Revision “A” is identified by the fact that there is no revision number on the PCB. The schematic is also available as a separate .PDF document on our website. Make sure to check our website periodically for updates.

## 7. References and resource URLs

The documents below provide further useful information.

1. PCF8883 product datasheet.
2. AN10832; PCF8883 – capacitive proximity switch with auto-calibration.

Table 2. Resource URLs

Item	Resource	Description and location
1	OM11055 eval kit document package	Includes: <ul style="list-style-type: none"> <li>• This document</li> <li>• Board schematic and BOM</li> <li>• Links to datasheets and application notes</li> <li>• Location: <a href="http://www.standardics.nxp.com/support/boards/PCF8883">http://www.standardics.nxp.com/support/boards/PCF8883</a></li> </ul>
2	PCF8883 webpage	Links to the datasheets and application notes <a href="http://www.nxp.com/pip/PCF8883_1.html">http://www.nxp.com/pip/PCF8883_1.html</a>

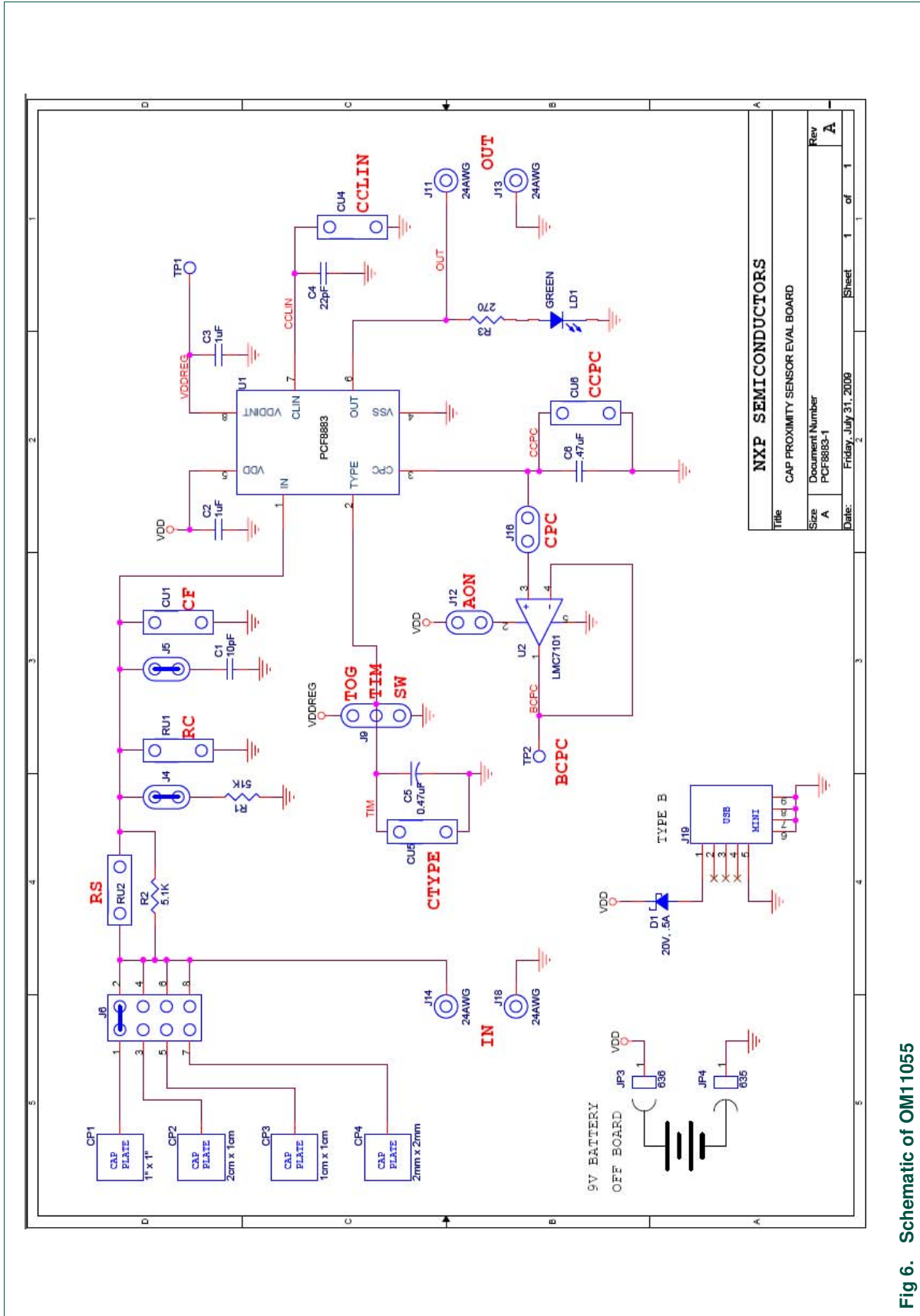

Fig 6. Schematic of OM11055

## 8. Legal information

### 8.1 Definitions

**Draft** — The document is a draft version only. The content is still under internal review and subject to formal approval, which may result in modifications or additions. NXP Semiconductors does not give any representations or warranties as to the accuracy or completeness of information included herein and shall have no liability for the consequences of use of such information.

### 8.2 Disclaimers

**General** — Information in this document is believed to be accurate and reliable. However, NXP Semiconductors does not give any representations or warranties, expressed or implied, as to the accuracy or completeness of such information and shall have no liability for the consequences of use of such information.

**Right to make changes** — NXP Semiconductors reserves the right to make changes to information published in this document, including without limitation specifications and product descriptions, at any time and without notice. This document supersedes and replaces all information supplied prior to the publication hereof.

**Suitability for use** — NXP Semiconductors products are not designed, authorized or warranted to be suitable for use in medical, military, aircraft, space or life support equipment, nor in applications where failure or malfunction of a NXP Semiconductors product can reasonably be expected

to result in personal injury, death or severe property or environmental damage. NXP Semiconductors accepts no liability for inclusion and/or use of NXP Semiconductors products in such equipment or applications and therefore such inclusion and/or use is for the customer's own risk.

**Applications** — Applications that are described herein for any of these products are for illustrative purposes only. NXP Semiconductors makes no representation or warranty that such applications will be suitable for the specified use without further testing or modification.

**Export control** — This document as well as the item(s) described herein may be subject to export control regulations. Export might require a prior authorization from national authorities.

### 8.3 Trademarks

Notice: All referenced brands, product names, service names and trademarks are property of their respective owners.

## 9. Contents

---

<b>1.</b>	<b>Introduction .....</b>	<b>3</b>
<b>2.</b>	<b>Quick start.....</b>	<b>3</b>
<b>3.</b>	<b>Board description and layout.....</b>	<b>4</b>
3.1	Setting the PCF8883 operation modes .....	4
<b>4.</b>	<b>User configurable settings .....</b>	<b>5</b>
4.1	Sensor plate selection .....	5
4.2	Sensitivity settings.....	6
4.3	Power supply options .....	7
4.4	High impedance op-amp .....	7
<b>5.</b>	<b>Sensor adjustment .....</b>	<b>7</b>
<b>6.</b>	<b>Board schematic .....</b>	<b>8</b>
<b>7.</b>	<b>References and resource URLs .....</b>	<b>8</b>
<b>8.</b>	<b>Legal information .....</b>	<b>10</b>
8.1	Definitions .....	10
8.2	Disclaimers.....	10
8.3	Trademarks.....	10
<b>9.</b>	<b>Contents.....</b>	<b>11</b>

---

Please be aware that important notices concerning this document and the product(s) described herein, have been included in the section 'Legal information'.

---



© NXP B.V. 2009. All rights reserved.

For more information, please visit: <http://www.nxp.com>  
For sales office addresses, email to: [salesaddresses@nxp.com](mailto:salesaddresses@nxp.com)

Date of release: 2 December 2009  
Document identifier: UM10370\_2