



Chipsmall Limited consists of a professional team with an average of over 10 year of expertise in the distribution of electronic components. Based in Hongkong, we have already established firm and mutual-benefit business relationships with customers from,Europe,America and south Asia,supplying obsolete and hard-to-find components to meet their specific needs.

With the principle of "Quality Parts,Customers Priority,Honest Operation,and Considerate Service",our business mainly focus on the distribution of electronic components. Line cards we deal with include Microchip,ALPS,ROHM,Xilinx,Pulse,ON,Everlight and Freescale. Main products comprise IC,Modules,Potentiometer,IC Socket,Relay,Connector.Our parts cover such applications as commercial,industrial, and automotives areas.

We are looking forward to setting up business relationship with you and hope to provide you with the best service and solution. Let us make a better world for our industry!



Contact us

Tel: +86-755-8981 8866 Fax: +86-755-8427 6832

Email & Skype: info@chipsmall.com Web: www.chipsmall.com

Address: A1208, Overseas Decoration Building, #122 Zhenhua RD., Futian, Shenzhen, China





NXP PCI Development Board OM4965/PNX1005E/2

PCI Development Platform for HD video processing based on PNX1005

Based on the latest PNX1005 from NXP Semiconductors, the OM4965 development board enables a software engineer to develop a range of algorithms and applications on the PNX1005, while using a standard and easy development environment on a PC. The development board comes with a range of inputs and outputs for audio and video, in both analog and digital way, providing the developer with the flexibility, needed to develop a wide range of software components.

Key features

- ▶ Based on PNX1005 TriMedia DSP media processor.
- ▶ HDMI up to 1080p/60 input and output
- ▶ Analog 4 channel composite video input
- ▶ Audio analog stereo input and output
- ▶ Ethernet
- ▶ USB
- ▶ Standard PCI form factor
- ▶ On board connectors for GPIO, EJTAG, I2C
- ▶ Schematics, Gerber files available

Key benefits

- ▶ Easily integrates in any standard PC
- ▶ PCI connection allows for fast debugging, access to files and network on the PC
- ▶ HDMI in/out enables zero-loss video inputs and outputs

Applications

- ▶ Video compression and decompression algorithms
- ▶ Video analytics for security
- ▶ Video optimization : intra-frame calculation and enhanced deinterlacing
- ▶ Algorithms for multi-channel acoustic procession
- ▶ USB and Network components

Block diagram

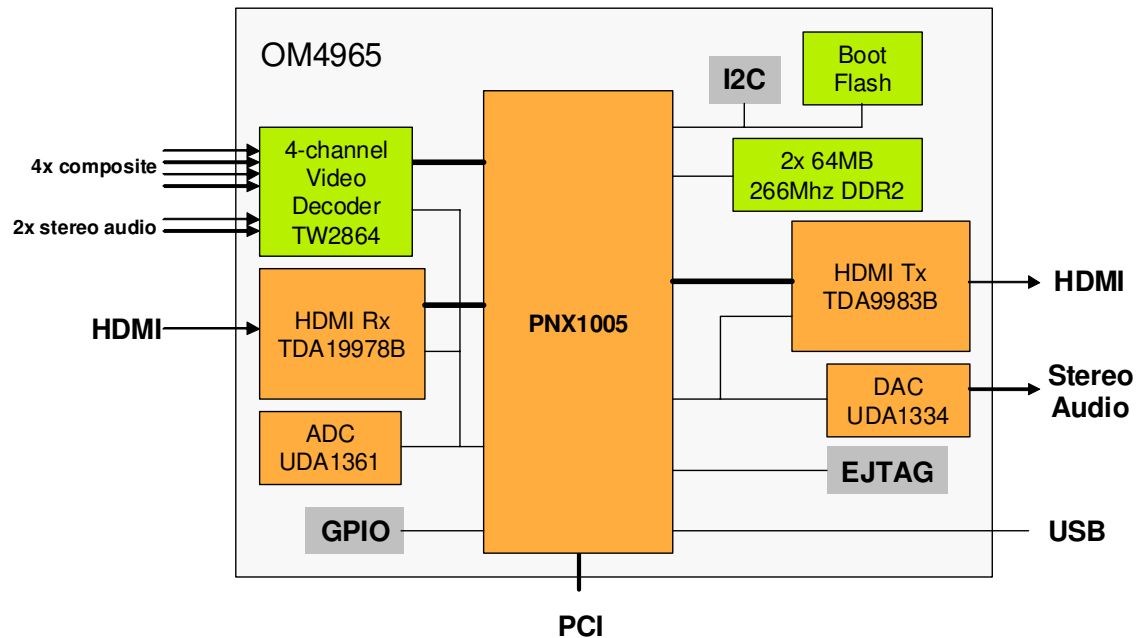

Front and side view

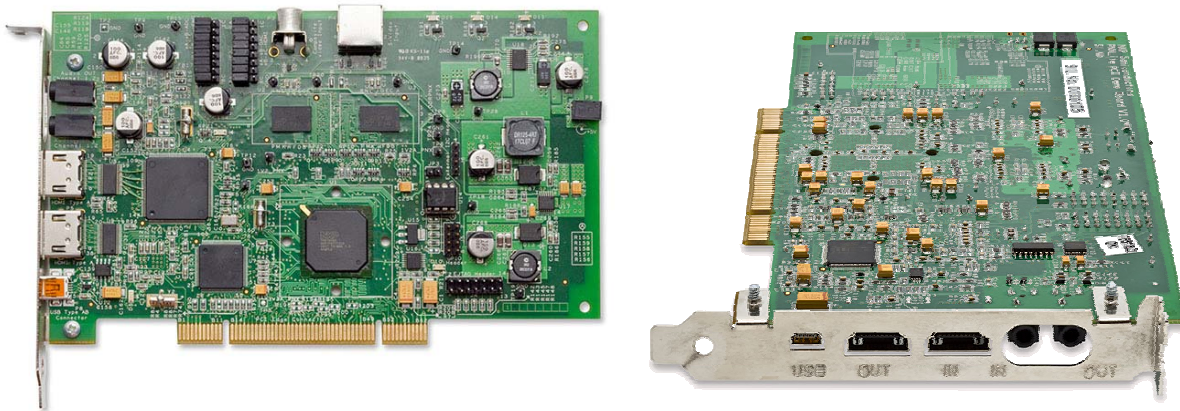

Specifications

- ▶ Processor: PNX1005E/400 400Mhz
- ▶ Memory: 128 MB DDR2 333Mhz DRAM operating at 266Mhz clock (533Mhz data rate)
- ▶ Analog audio/video input : Techwell TW2864 4-channel video decoder
- ▶ Digital audio/video input : NXP TDA19978B HDMI receiver (up to 1080p with 8 channel audio)
- ▶ Video audio/output : NXP TDA9983B HDMI transmitter (up to 1080p with 8 channel audio)
- ▶ Analog audio input/output: NXP UDA1361 and UDA1334 stereo ADC and DAC
- ▶ USB 2.0 High-Speed OTG with a mini-AB connector
- ▶ General Purpose I/O : 8 GPIO lines on 1" pitch IDC header
- ▶ EJTAG interface, I2C interface and jumper blocks
- ▶ PCI Interface : Universal 3.3/5V signaling card, PCI 2.2 compliant, supports 66Mhz operation
- ▶ Dimensions: Full height, half length PCI card