



Chipsmall Limited consists of a professional team with an average of over 10 year of expertise in the distribution of electronic components. Based in Hongkong, we have already established firm and mutual-benefit business relationships with customers from,Europe,America and south Asia,supplying obsolete and hard-to-find components to meet their specific needs.

With the principle of "Quality Parts,Customers Priority,Honest Operation,and Considerate Service",our business mainly focus on the distribution of electronic components. Line cards we deal with include Microchip,ALPS,ROHM,Xilinx,Pulse,ON,Everlight and Freescale. Main products comprise IC,Modules,Potentiometer,IC Socket,Relay,Connector.Our parts cover such applications as commercial,industrial, and automotives areas.

We are looking forward to setting up business relationship with you and hope to provide you with the best service and solution. Let us make a better world for our industry!



Contact us

Tel: +86-755-8981 8866 Fax: +86-755-8427 6832

Email & Skype: info@chipsmall.com Web: www.chipsmall.com

Address: A1208, Overseas Decoration Building, #122 Zhenhua RD., Futian, Shenzhen, China



AN11035

50 Ohm FM LNA for embedded Antenna in Portable applications with BGU7003W

Rev. 1.0 — 15 July 2011

Application note

Document information

Info	Content
Keywords	BGU7003W, LNA, FM, embedded Antenna
Abstract	The document provides circuit, layout, BOM and performance information on FM band using BGU7003W



Revision history

Rev	Date	Description
1.0	20110715	Initial document

Contact information

For more information, please visit: <http://www.nxp.com>

For sales office addresses, please send an email to: salesaddresses@nxp.com

1. Introduction

„Music“ as mobile value proposition has become increasingly popular in recent years. Transferring MP3 from the PC and playing on the mobile is now common, eased by decline in memory prices. This trend has re-ignited interest in FM Radio on Mobile as people want to keep up with the news, listen to new music, in addition to playing their MP3 collection.

With NXP,s FM LNA’s consumers can listen to FM Radio on their mobile phone speaker. They amplify the weak signal solving impedance mismatch between embedded antennas and the FM Radio receiver.

2. Application Circuit

The FM LNA application circuit is built with BGU7003W (LNA MMIC). It needs 10 (11 components used in the EVB) external components for matching, biasing and decoupling. The layout has also additional foot print for 0402 components, those are reserved for different applications or ESD protection and matching purpose.

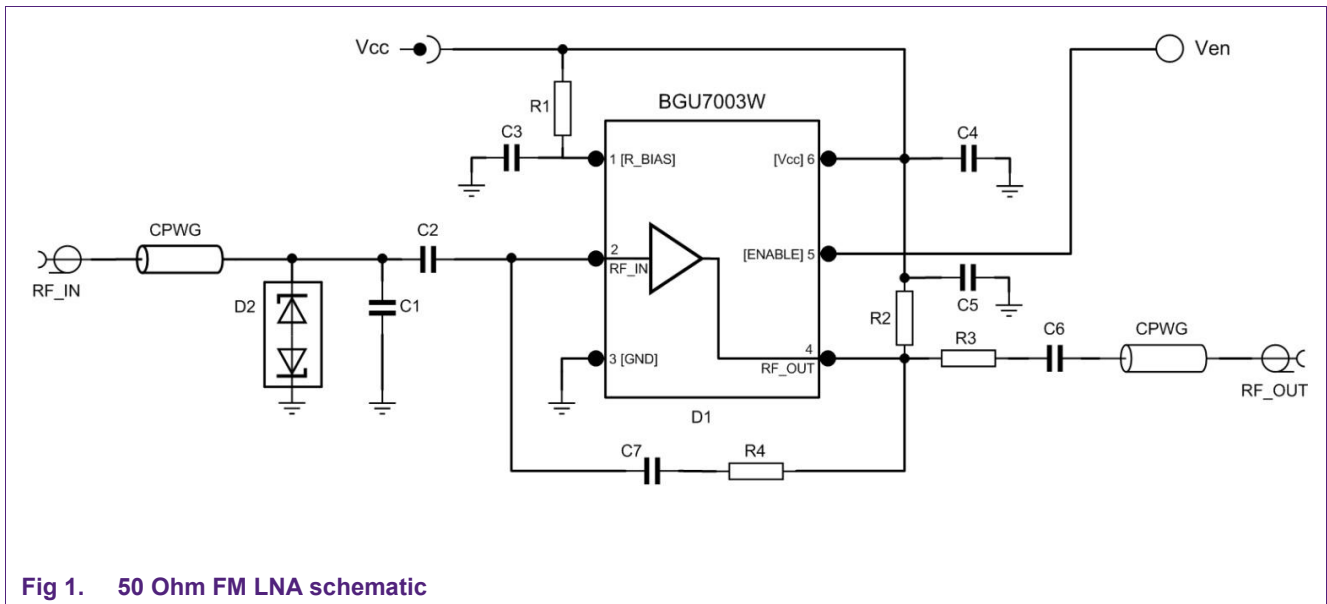

2.1 Components

Table 1. Bill of materials

Component	Position on Layout	Value	Unit	Type	Remark
C1	Z3	0.56	pF	MurataGRM1555	Stability (in case of using D2, C1 is not necessary)
C2, C6, C7	Z4, Z15, Z8	330	pF	MurataGRM1555	DC blocking
C3, C5, C4	Z6, Z9, Z20	47	nF		DC decoupling (C4 is not necessary)
R1	Z7	4.7	kΩ		Bias setting
R2	Z11	180	Ω		Stability / Matching
R3	Z13	10	Ω		Stability
R4	Z12	680	Ω		Feedback / Matching
	Z1, Z16, Z19, Z21	0	Ω		Jumper Reserved for ESD & matching
	Z5, Z10, Z14, Z17, Z18	NC			Not connected Reserved for ESD & matching
D1	D1			BGU7003W	
D2	Z2			PESD5V0F1BL	ESD Diode (optional)

2.2 PCB Layout

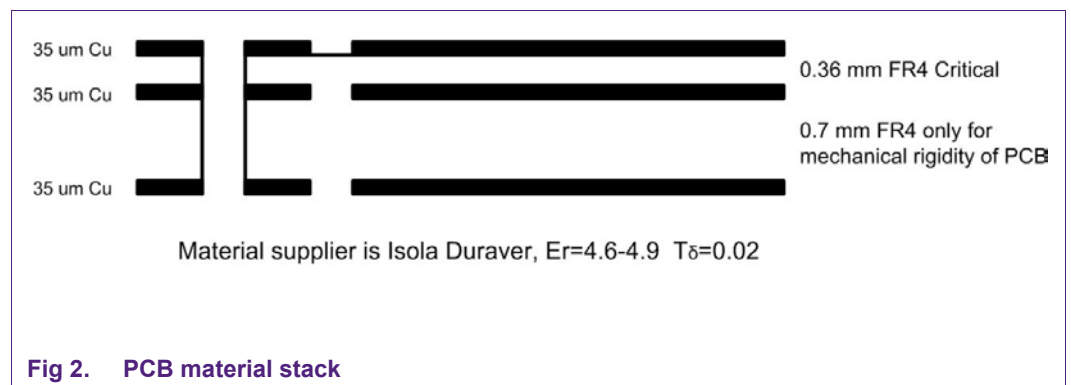

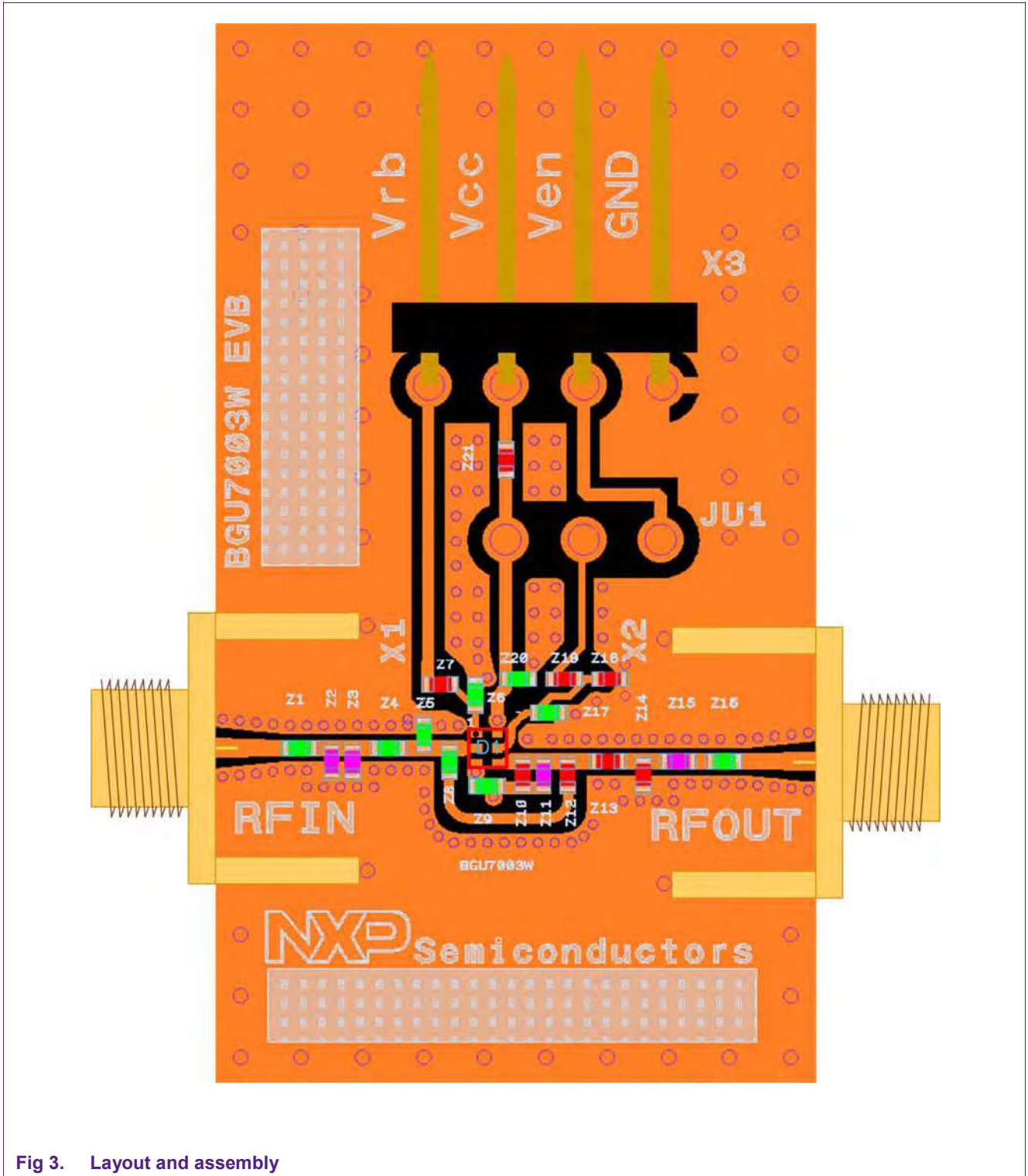

Fig 3. Layout and assembly

3. Measurement results

3.1 Measurement results

Table 2. Typical measurement results measured on the evaluation board

$T_{amb} = 25\text{ }^{\circ}\text{C}$; $V_{cc} = V_{en} = V_{rb} = 2.8\text{ V}$; $I_{CC(tot)} = 4.3\text{ mA}$ ^[1]; $f = 100\text{ MHz}$; $Z_S = Z_L = 50\text{ }\Omega$ unless otherwise specified. All measurements are done with SMA-connectors as reference plane.

Parameter	Symbol	Value	Unit	Remark
supply voltage	V_{cc}	2.8	V	
supply current	I_{CC} ^[1]	4.3	mA	
noise figure	NF	1.5	dB	
insertion power gain	$ S_{21} ^2$	15	dB	
input return loss	RL_{in}	9	dB	
output return loss	RL_{out}	14	dB	
input power at 1 dB gain compression	$P_{i(1dB)}$	-20	dBm	
output power at 1 dB gain compression	$P_{o(1dB)}$	-6	dBm	
input third-order intercept point	$IP3_I$ ^[2]	-12.5	dBm	
output third-order intercept point	$IP3_O$ ^[2]	2.5	dBm	

[1] $I_{CC(tot)} = I_{CC} + I_{RF_OUT} + I_{R_BIAS}$

[2] The third order intercept point is measured at -30 dBm per tone at RF_IN ($f_1 = 100\text{ MHz}$; $f_2 = 100.2\text{ MHz}$)

3.2 Graphs

All the measurements have done on the application board. The reference planes for the measurements are the SMA-connectors on the application board.

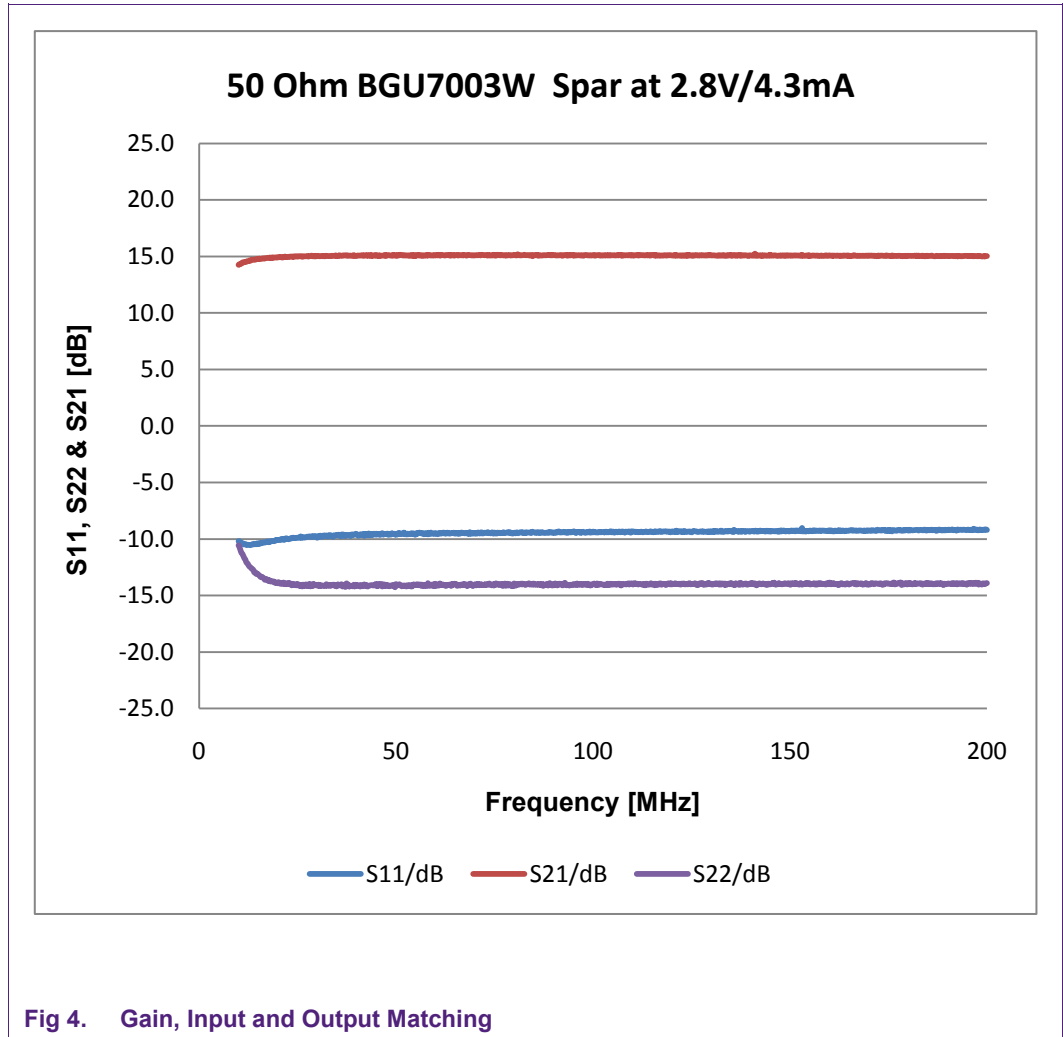

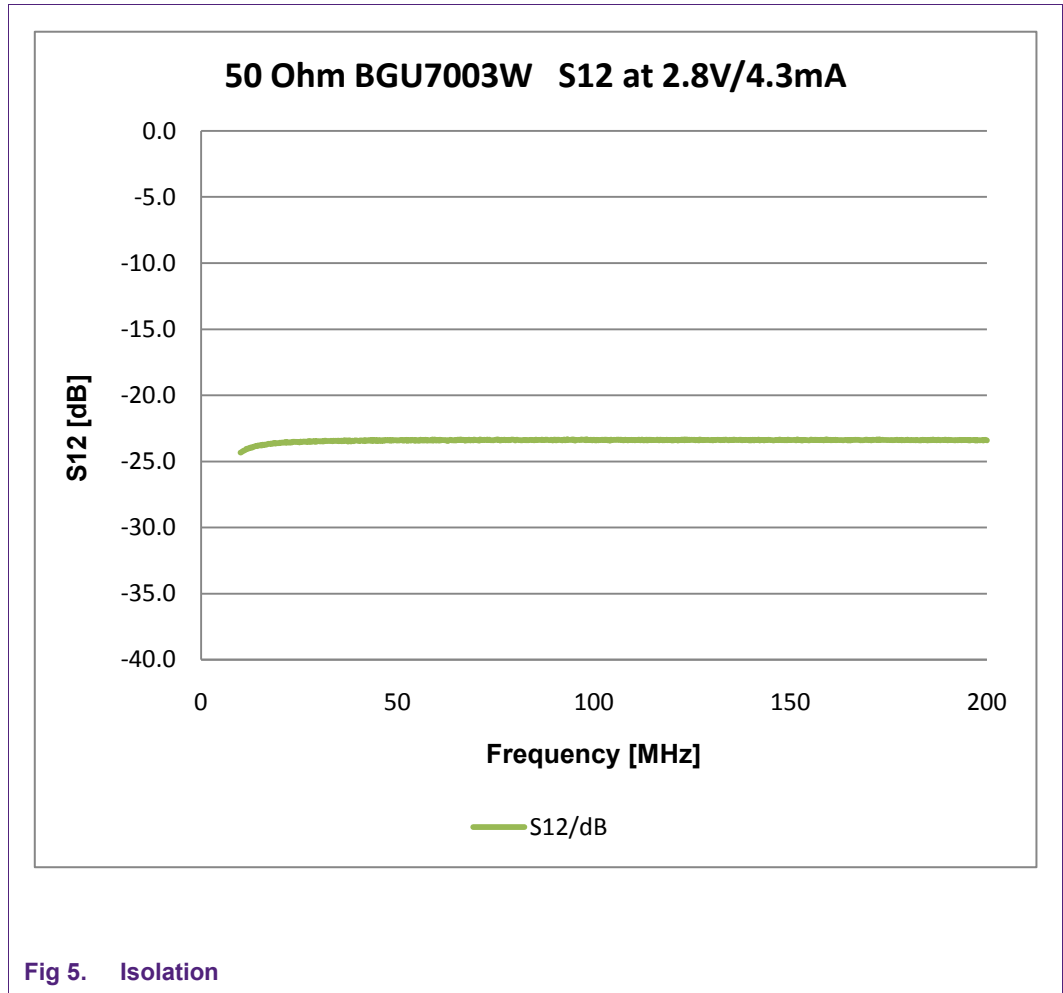

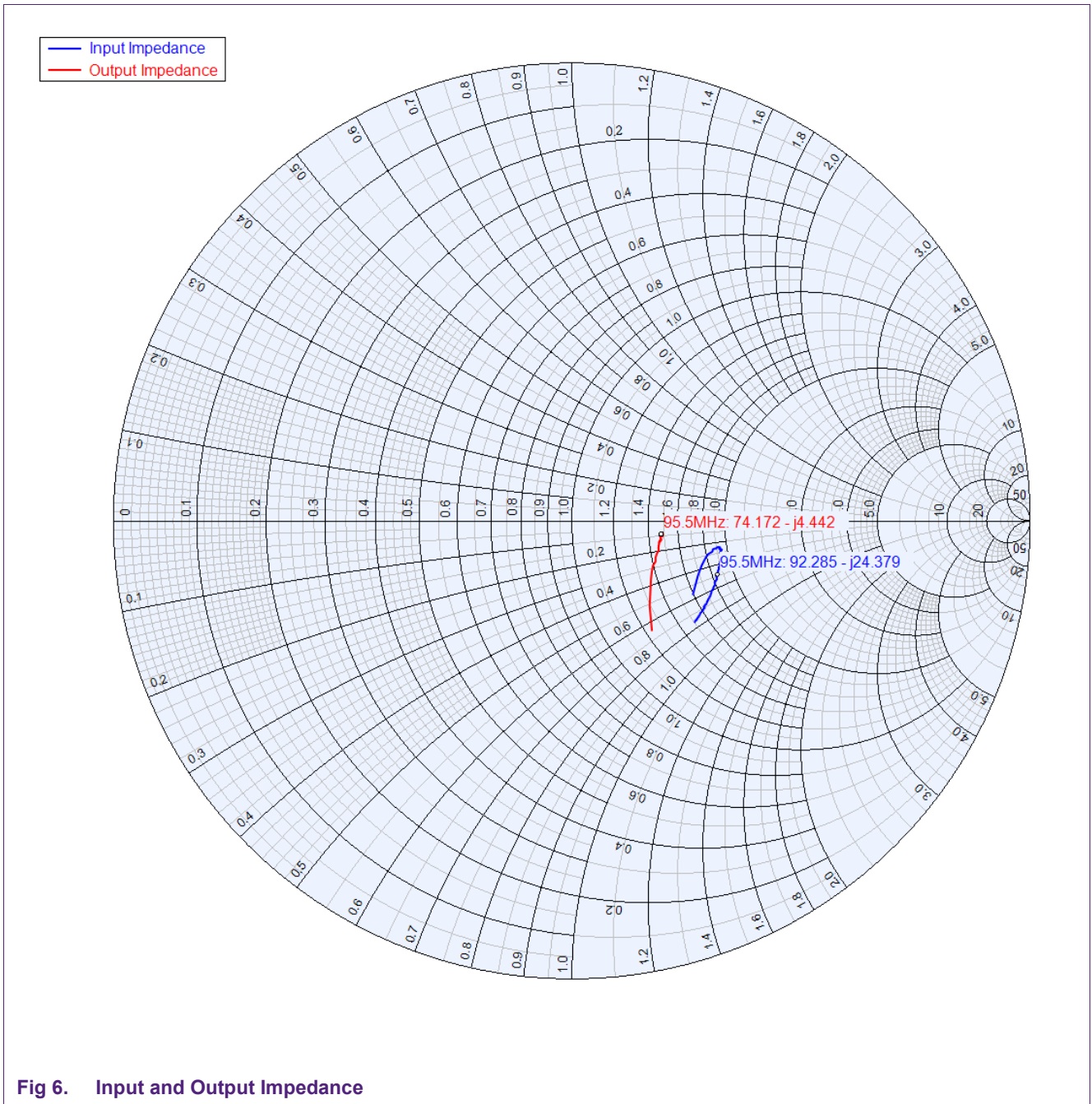
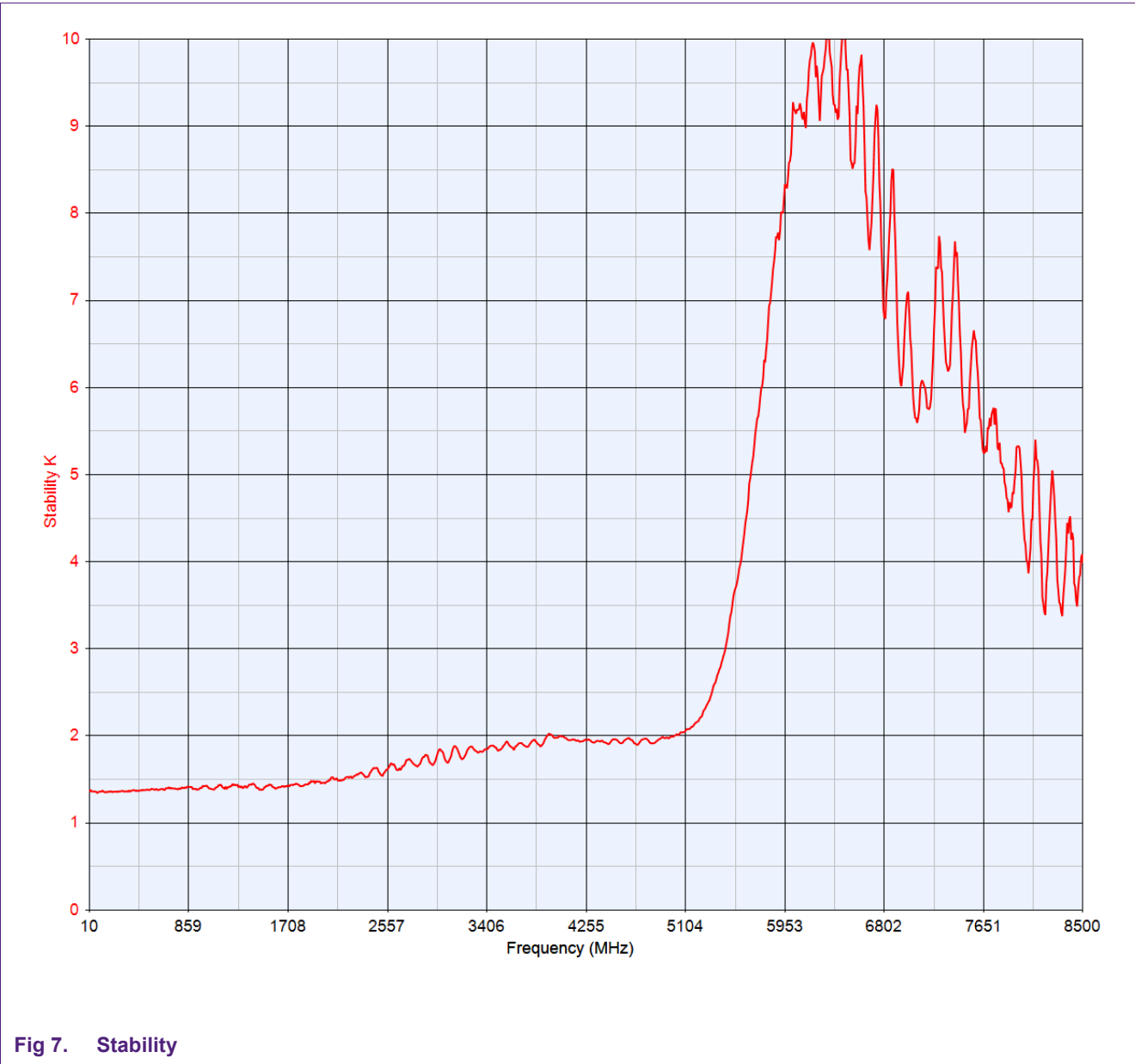

Fig 6. Input and Output Impedance



4. Legal information

4.1 Definitions

Draft — The document is a draft version only. The content is still under internal review and subject to formal approval, which may result in modifications or additions. NXP Semiconductors does not give any representations or warranties as to the accuracy or completeness of information included herein and shall have no liability for the consequences of use of such information.

4.2 Disclaimers

Limited warranty and liability — Information in this document is believed to be accurate and reliable. However, NXP Semiconductors does not give any representations or warranties, expressed or implied, as to the accuracy or completeness of such information and shall have no liability for the consequences of use of such information.

In no event shall NXP Semiconductors be liable for any indirect, incidental, punitive, special or consequential damages (including - without limitation - lost profits, lost savings, business interruption, costs related to the removal or replacement of any products or rework charges) whether or not such damages are based on tort (including negligence), warranty, breach of contract or any other legal theory.

Notwithstanding any damages that customer might incur for any reason whatsoever, NXP Semiconductors' aggregate and cumulative liability towards customer for the products described herein shall be limited in accordance with the Terms and conditions of commercial sale of NXP Semiconductors.

Right to make changes — NXP Semiconductors reserves the right to make changes to information published in this document, including without limitation specifications and product descriptions, at any time and without notice. This document supersedes and replaces all information supplied prior to the publication hereof.

Suitability for use — NXP Semiconductors products are not designed, authorized or warranted to be suitable for use in life support, life-critical or safety-critical systems or equipment, nor in applications where failure or malfunction of an NXP Semiconductors product can reasonably be expected to result in personal injury, death or severe property or environmental damage. NXP Semiconductors accepts no liability for inclusion and/or use of NXP Semiconductors products in such equipment or applications and therefore such inclusion and/or use is at the customer's own risk.

Applications — Applications that are described herein for any of these products are for illustrative purposes only. NXP Semiconductors makes no representation or warranty that such applications will be suitable for the specified use without further testing or modification.

Customers are responsible for the design and operation of their applications and products using NXP Semiconductors products, and NXP Semiconductors accepts no liability for any assistance with applications or

customer product design. It is customer's sole responsibility to determine whether the NXP Semiconductors product is suitable and fit for the customer's applications and products planned, as well as for the planned application and use of customer's third party customer(s). Customers should provide appropriate design and operating safeguards to minimize the risks associated with their applications and products.

NXP Semiconductors does not accept any liability related to any default, damage, costs or problem which is based on any weakness or default in the customer's applications or products, or the application or use by customer's third party customer(s). Customer is responsible for doing all necessary testing for the customer's applications and products using NXP Semiconductors products in order to avoid a default of the applications and the products or of the application or use by customer's third party customer(s). NXP does not accept any liability in this respect.

Export control — This document as well as the item(s) described herein may be subject to export control regulations. Export might require a prior authorization from national authorities.

Evaluation products — This product is provided on an "as is" and "with all faults" basis for evaluation purposes only. NXP Semiconductors, its affiliates and their suppliers expressly disclaim all warranties, whether express, implied or statutory, including but not limited to the implied warranties of non-infringement, merchantability and fitness for a particular purpose. The entire risk as to the quality, or arising out of the use or performance, of this product remains with customer.

In no event shall NXP Semiconductors, its affiliates or their suppliers be liable to customer for any special, indirect, consequential, punitive or incidental damages (including without limitation damages for loss of business, business interruption, loss of use, loss of data or information, and the like) arising out the use of or inability to use the product, whether or not based on tort (including negligence), strict liability, breach of contract, breach of warranty or any other theory, even if advised of the possibility of such damages.

Notwithstanding any damages that customer might incur for any reason whatsoever (including without limitation, all damages referenced above and all direct or general damages), the entire liability of NXP Semiconductors, its affiliates and their suppliers and customer's exclusive remedy for all of the foregoing shall be limited to actual damages incurred by customer based on reasonable reliance up to the greater of the amount actually paid by customer for the product or five dollars (US\$5.00). The foregoing limitations, exclusions and disclaimers shall apply to the maximum extent permitted by applicable law, even if any remedy fails of its essential purpose.

4.3 Trademarks

Notice: All referenced brands, product names, service names and trademarks are property of their respective owners.

5. List of figures

Fig 1. 50 Ohm FM LNA schematic.....3
Fig 2. PCB material stack4
Fig 3. Layout and assembly5
Fig 4. Gain, Input and Output Matching7
Fig 5. Isolation.....8
Fig 6. Input and Output Impedance.....9
Fig 7. Stability 10

6. List of tables

Table 1. Bill of materials.....4
Table 2. Typical measurement results measured on the
evaluation board6

7. Contents

1.	Introduction	3
2.	Application Circuit	3
2.1	Components	4
2.2	PCB Layout	4
3.	Measurement results	6
3.1	Measurement results	6
3.2	Graphs	7
4.	Legal information	11
4.1	Definitions	11
4.2	Disclaimers	11
4.3	Trademarks	11
5.	List of figures	12
6.	List of tables	13
7.	Contents	14

Please be aware that important notices concerning this document and the product(s) described herein, have been included in the section 'Legal information'.

© NXP B.V. 2011.

All rights reserved.

For more information, visit: <http://www.nxp.com>

For sales office addresses, please send an email to: salesaddresses@nxp.com

Date of release: 15 July 2011

Document identifier: AN11035