



Chipsmall Limited consists of a professional team with an average of over 10 year of expertise in the distribution of electronic components. Based in Hongkong, we have already established firm and mutual-benefit business relationships with customers from,Europe,America and south Asia,supplying obsolete and hard-to-find components to meet their specific needs.

With the principle of “Quality Parts,Customers Priority,Honest Operation,and Considerate Service”,our business mainly focus on the distribution of electronic components. Line cards we deal with include Microchip,ALPS,ROHM,Xilinx,Pulse,ON,Everlight and Freescale. Main products comprise IC,Modules,Potentiometer,IC Socket,Relay,Connector.Our parts cover such applications as commercial,industrial, and automotives areas.

We are looking forward to setting up business relationship with you and hope to provide you with the best service and solution. Let us make a better world for our industry!



Contact us

Tel: +86-755-8981 8866 Fax: +86-755-8427 6832

Email & Skype: info@chipsmall.com Web: www.chipsmall.com

Address: A1208, Overseas Decoration Building, #122 Zhenhua RD., Futian, Shenzhen, China



SPECIFICATION

- Part No.** : **OMB.433.B06F21**
- Description** : 433MHz 6dBi Omni Directional Outdoor Antenna with N Type Female Connector, U-Bolt, 1094mm Length
- Features** : Omni-Directional Radiation Pattern
Collinear
6dBi Peak gain, 433 MHz
Fiberglass Housing
Robust design for all weather operation
IP65 waterproof
Length: 1,094mm | Weight: 1,300g
N type Female connector
Wall mount bracket included
RoHS compliant



1. Introduction

The OMB.433.B06F21 is a 6dBi fiberglass omni-directional outdoor antenna, operating in 433 MHz ISM band. The antenna is designed for applications such as metering, industrial/environmental monitoring, remote asset monitoring and mesh network applications.

The OMB.433 operates at 433MHz, one of the most widely used license free ISM bands, with a 6dBi peak gain. The omni-directional antenna radiates uniformly in the azimuth providing coverage over long distances. Coupled with a very low VSWR, this characteristic provides the best performance because the antenna gives maximum coverage range in the horizontal plane over 360 degrees, thus minimizing the amount of nodes needed for a mesh network.

The UV resistant fiberglass housing enables the OMB antenna to be utilized in all kinds of harsh environments, making it more robust and safer than traditional whip antennas. It can be connected directly to the access point or telemetry unit, or can be mounted on wall or device surface via the N-type connector.

A smaller model, OMB.433.B03F21, with 3dBi peak gain, is also available.

2. Specification

ELECTRICAL	
Standard	ISM 433
Band	433 MHz
Antenna Type	Collinear Dipole Array
Peak Gain	6 dBi
Polarization	Vertical
Impedance	50 ohms
Max Input Power	100 watts
VSWR	1.5:1
Radiation	Omni-Directional
Vertical Beamwidth	36 Deg
Horizontal Beamwidth	360 Deg
Internal Material	Copper
Connector	N Type Female
MECHANICAL	
Length	1094 mm(Max)
Bracket Dimension	70 x 35mm(Max)
Antenna Weight	1300g
Mounting Accessories Weight	70g
Application	Indoor/Outdoor
Radome Material	White Fiberglass
Bracket Material	Aluminum
Mount Style	Pole Mount/Wall Mount
Mount Hardware Material	Stainless Steel
Wind Resistance	>150mph (>241km/h)
Waterproof	IP65

ENVIRONMENTAL	
Storage Temperature	-40°C to +85°C
Operating Temperature	-40°C to +85°C
Operating Humidity	10%~90% non-condensing
Storage Humidity	5%~90% non-condensing

3. Antenna Characteristics

3.1 VSWR

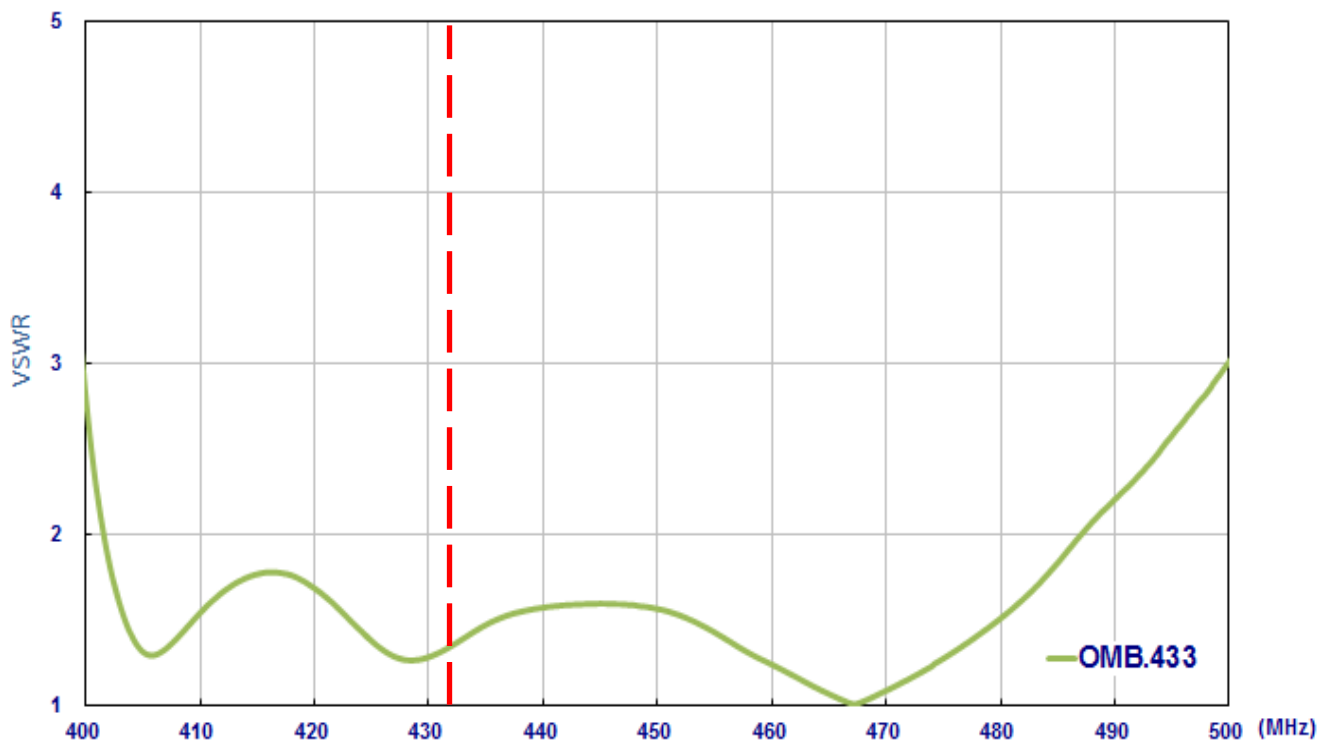

3.2 Peak Gain

E-plane

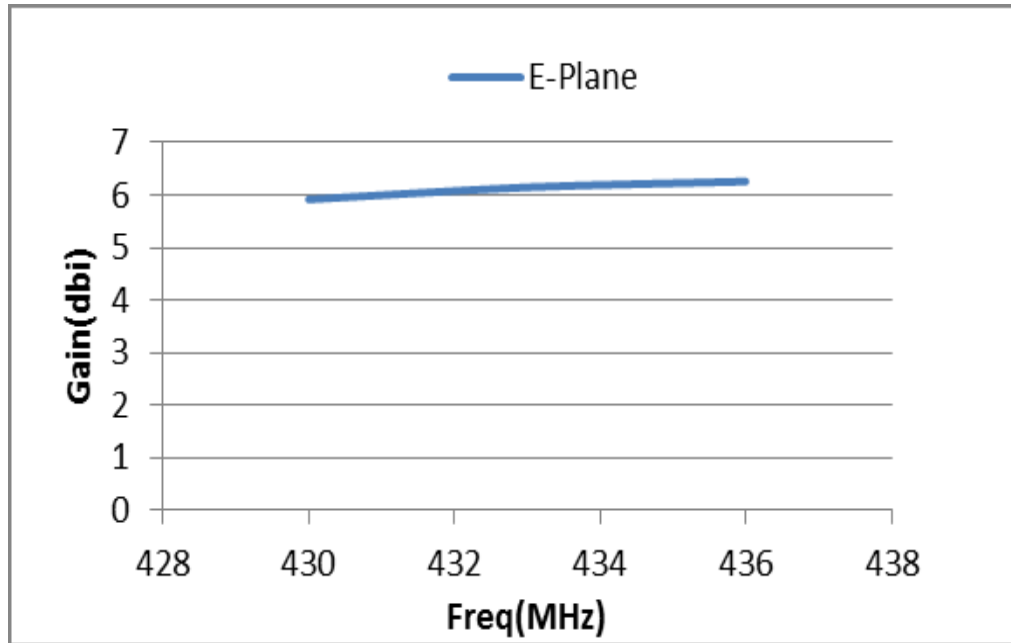

H-plane

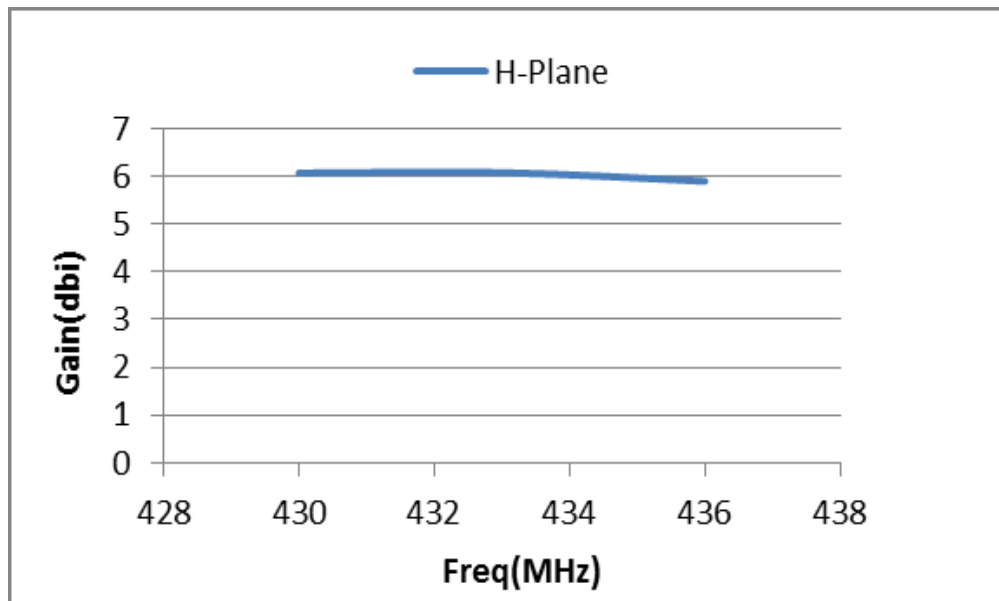

4. Antenna Radiation Pattern

4.1 Measurement Setup

Vertical Pattern – E plane

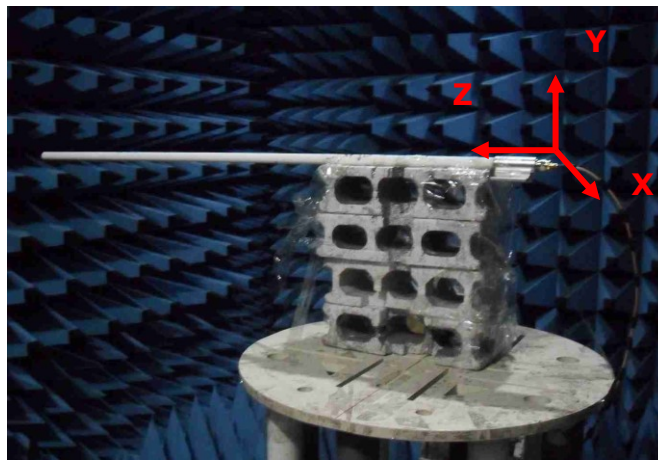

Horizontal Pattern – H plane

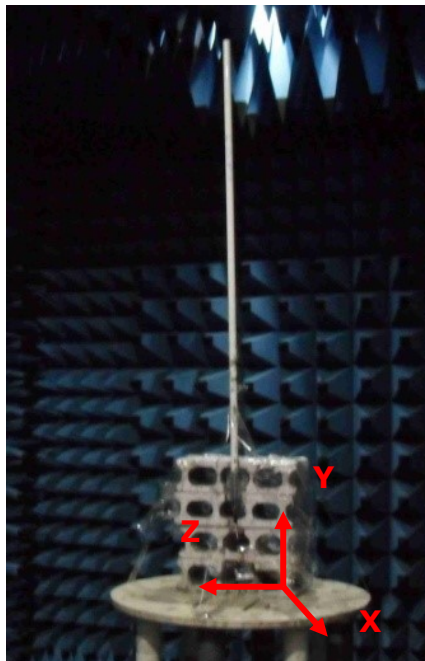

4.2 2D Radiation Pattern

Vertical Pattern – E plane

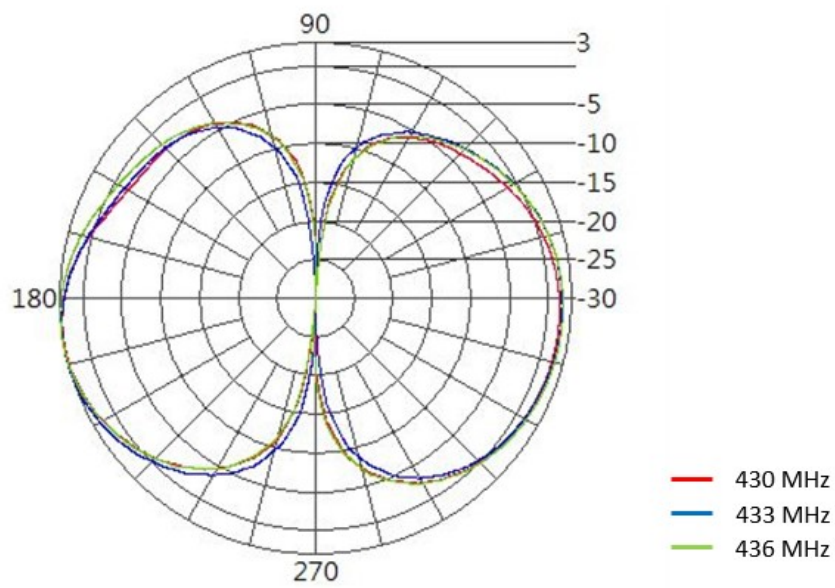

Horizontal Pattern – H plane

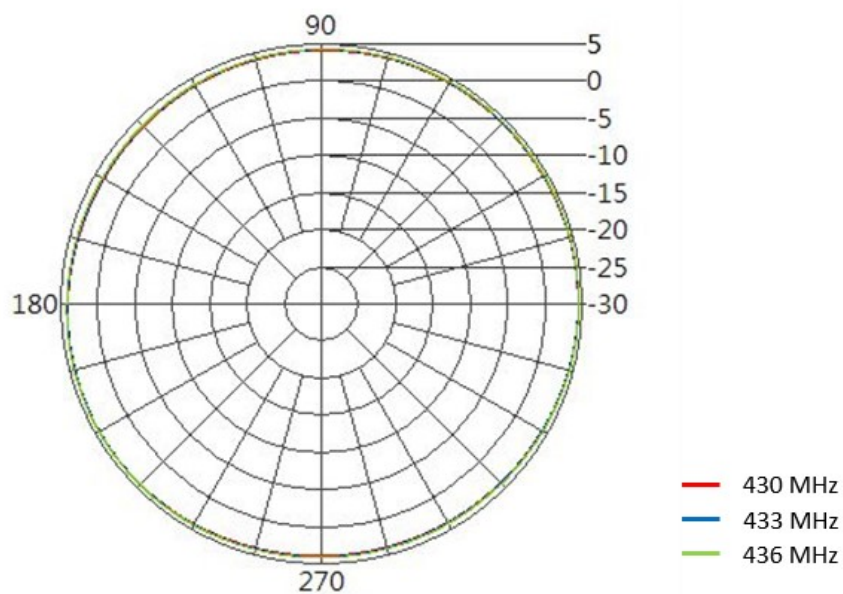

5. Mechanical Drawing (Unit: mm)

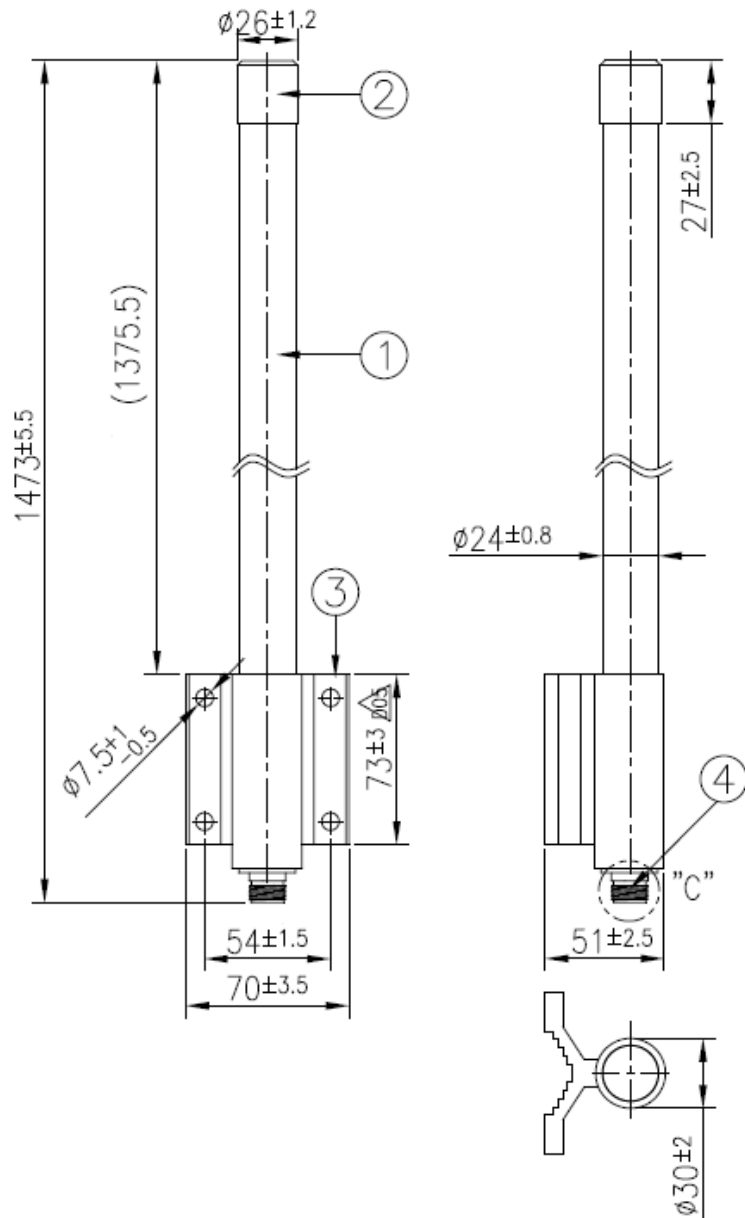
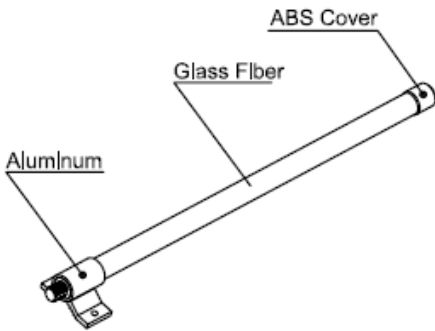

U Bolt(m6x1.0)

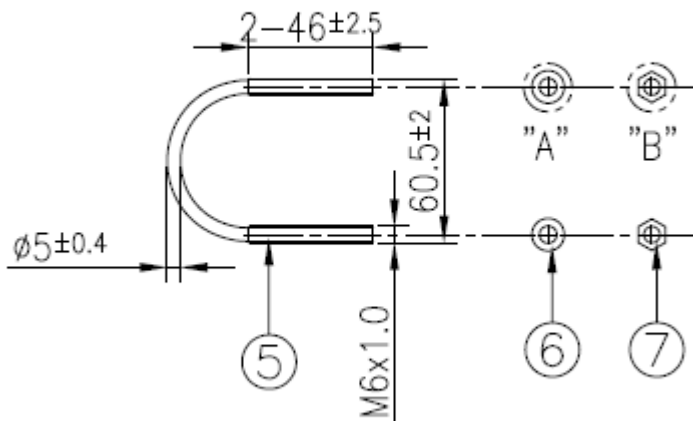

N Type(F)

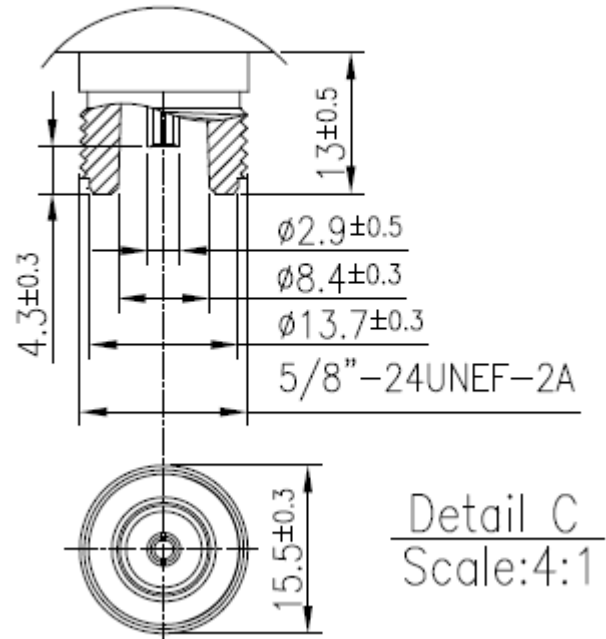

Detail C
Scale:4:1

Washer

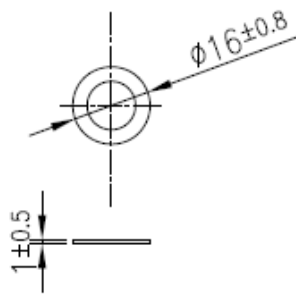

Detail A
Scale:2:1

Nut

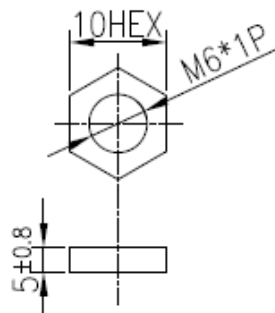

Detail B
Scale:2:1

	Name	P/N	Material	Finish	QTY
1	OMB.433 Antenna	001215A000021A	Fiberglass	White	1
2	Cover	000111K000021A	ABS	Sliver	1
3	Bracket	000312B000021A	Aluminum	Silver	1
4	N Type(F)	201211K000021A	Brass	Ni Plated	1
5	M6 U Bolt	000412B000021A	Stainless Steel	Sliver	2
6	M6 Washer	000411K010021A	Stainless Steel	Silver	4
7	M6 Nut	000411K020021A	Stainless Steel	Sliver	4



6. Packaging

OMB.433.B06F21

Packaging Specifications

1 OMB.433.B06F21 per PE Bag
 Bag Dimensions 130mm*1300mm
 1 PE Bag per Tube
 Tube Dimensions - Ø80mm*Height 1150mm
 Total Weight - 1.16Kg

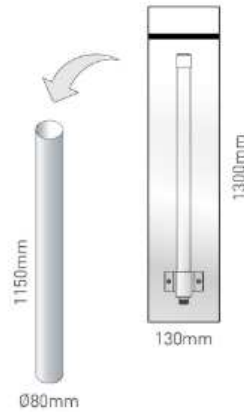

10 tubes per carton
 Carton Dimensions - 1160*410*180mm
 Weight - 13.12Kg

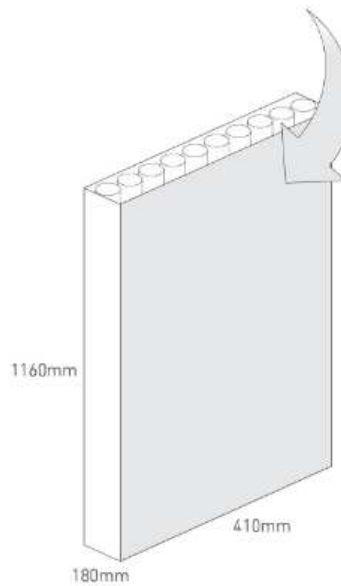

Pallet dimensions 1200*1100*1410mm
 14 Cartons per pallet

