



Chipsmall Limited consists of a professional team with an average of over 10 year of expertise in the distribution of electronic components. Based in Hongkong, we have already established firm and mutual-benefit business relationships with customers from,Europe,America and south Asia,supplying obsolete and hard-to-find components to meet their specific needs.

With the principle of “Quality Parts,Customers Priority,Honest Operation,and Considerate Service”,our business mainly focus on the distribution of electronic components. Line cards we deal with include Microchip,ALPS,ROHM,Xilinx,Pulse,ON,Everlight and Freescale. Main products comprise IC,Modules,Potentiometer,IC Socket,Relay,Connector.Our parts cover such applications as commercial,industrial, and automotives areas.

We are looking forward to setting up business relationship with you and hope to provide you with the best service and solution. Let us make a better world for our industry!



## Contact us

Tel: +86-755-8981 8866 Fax: +86-755-8427 6832

Email & Skype: info@chipsmall.com Web: www.chipsmall.com

Address: A1208, Overseas Decoration Building, #122 Zhenhua RD., Futian, Shenzhen, China



The Wakefield- Vette omniKlip heat sink series are a configurable and patented (Pat. Pending) high performance, low cost and compact solutions for TO-220, TO-247 and TO-264 , or similar packages. This powerful heat sink provides tool and fixture free assembly operation, largest surface areas and smallest space occupation. It is the ideal type of heat sink for high power density and small size (1U or 2U) electronic packaging with forced convention cooling.

**Features & Benefits**

• **Minimum assembly cost and labor**

Spring Clips make the mounting holes, fasteners, tools and fixtures obsolete in assembly operations & reduce costs.

• **Maximum Repeatability**

Constant spring force over repeated assembly/disassembly

• **Maximum Reliability**

Resilient spring action locks electronic component in place. Fewer parts in assembly and no fasteners and washers required. Prevent short circuit by eliminating metal particles generated from hardware or thread tapping

• **Design Flexibility**

Maximum flexibility for dynamic device locations and power up grading. **“Configure-to-Fit”** gives designers total freedom to configure heat sink needed to fit their dynamic design environments.

**Specifications**

- **Heat Sink:** Aluminum Alloy 6063-T5 or Equivalent with black anodized finish.
- **Spring Clip:** Music Wire, Per ASTM A228 with bright nickel plating
- **Solder Foot:** Cold-rolled Steel, Per ASTM A-366 with pure tin over copper strike. RoHS compliant.

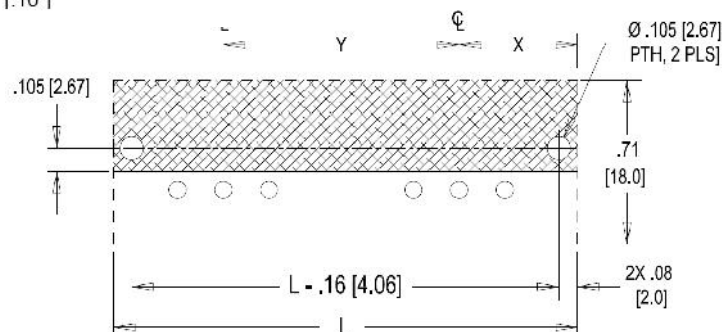
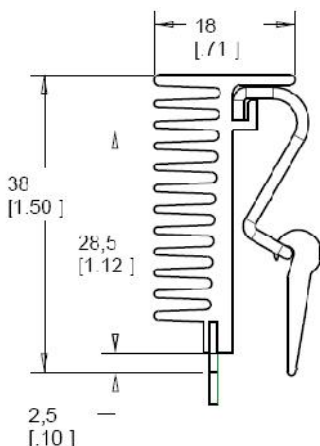

WkV Part Number	Description	Related Clip	Package Cooled	Length	Width	Height Off Base (Height of Fin)
OMNI-UNI-18-25	OmniKlip Heat Sink , 18mm wide, 25mm long, black anodized for TO-247 & TO-264	OMNI-UC	TO-247, TO-264	0.984" (25.00mm)	1.500" (38.10mm)	0.710" (18.03mm)
OMNI-UNI-18-50	OmniKlip Heat Sink , 18mm wide, 50mm long, black anodized for TO-247 & TO-264	OMNI-UC	TO-247, TO-264	1.969" (50.00mm)	1.500" (38.10mm)	0.710" (18.03mm)
OMNI-UNI-18-75	OmniKlip Heat Sink, 18mm wide, 75mm long, black anodized for TO-247 & TO 264	OMNI-UC	TO-247, TO-264	2.95" (75.00mm)	1.500" (38.10mm)	0.710" (18.03mm)
OMNI-220-18-25-1C	OmniKlip Heat Sink w/1 clip, 18mm wide, 25mm long, black anodized for TO-220		TO-220	0.984" (25.00mm)	1.500" (38.10mm)	0.710" (18.03mm)
OMNI-220-18-50-2C	OmniKlip Heat Sink w/2 clips, 18mm wide, 50mm long, black anodized for TO-220		TO-220	1.969" (50.00mm)	1.500" (38.10mm)	0.710" (18.03mm)
OMNI-220-18-75-3C	OmniKlip Heat Sink w/3 clips, 18mm wide, 75mm long, black anodized for TO-220		TO-220	2.95" (75.00mm)	1.500" (38.10mm)	0.710" (18.03mm)

**THERMAL PERFORMANCE (OMNI-UNI-18)**

Two TO-247 devices with Sil-pad 900s, L = 50mm [2.0"]

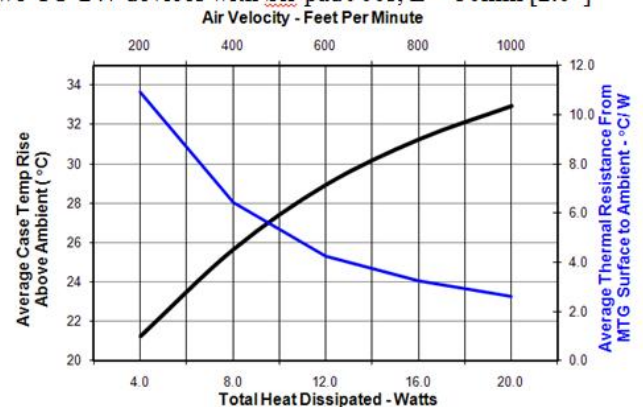



**OMNI-UNI-32-L Series Heat Sink**



WkV Part Number	Description	Related Cross Sell Part	Package Cooled	Shape	Length	Width	Height Off Base (Height of Fin)
OMNI-UNI-32-58	Omniklip Heat Sink for 2 universal 2 clips, 32mm wide, 58mm long, black anodized for any TO except TO220	OMNI-UC, OMNI-220C	TO-247, TO-264	Rectangular, Fins	2.28" (58mm)	1.25" (32mm)	1.62 (46.3mm)

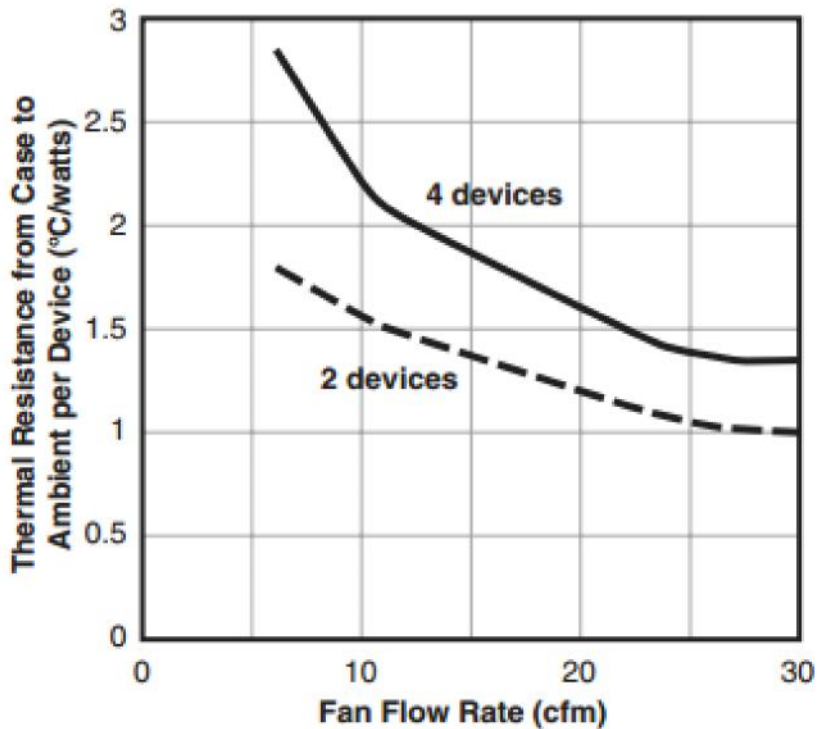
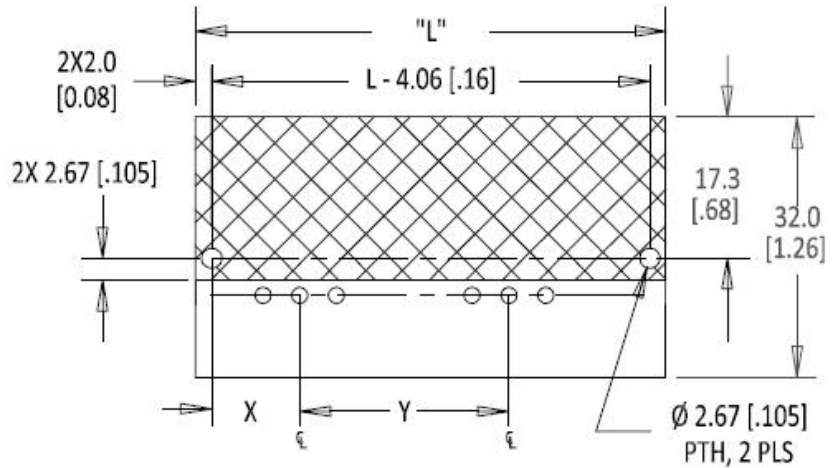
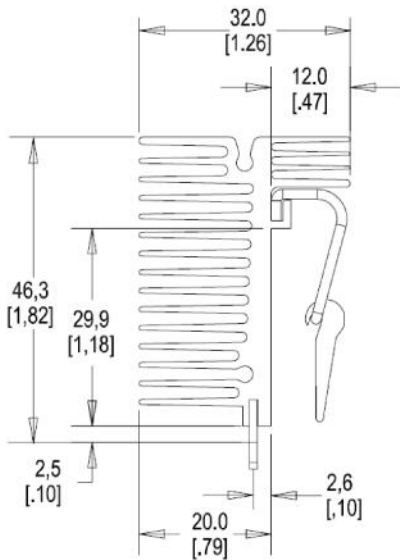



**OMNI-UNI-41-L Series Heat Sink**

WkV Part Number	Description	Related Cross Sell Part	Package Cooled	Shape	Length	Width	Height Off Base (Height of Fin)
OMNI-UNI-41-75	OmniKlip Heat Sink for 2 universal clips, 41mm wide, 75mm long, black anodized for any TO except TO220	OMNI-UC, OMNI-220C	TO-247, TO-264	Rectangular, Fins	2.95" (75mm)	1.61" (41mm)	1.62 (46.3mm)

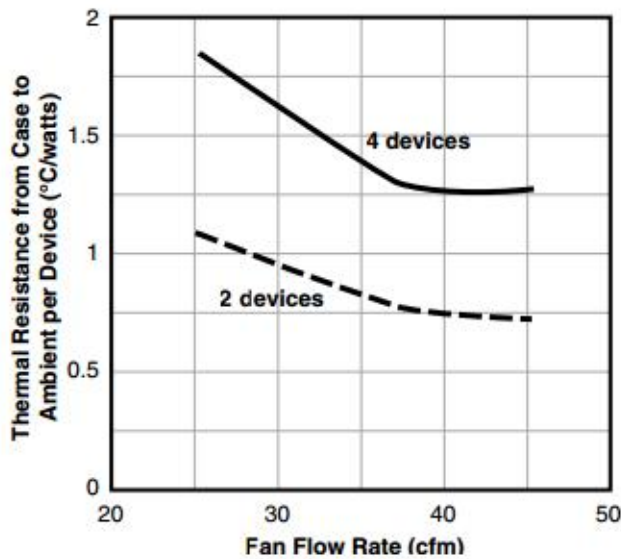
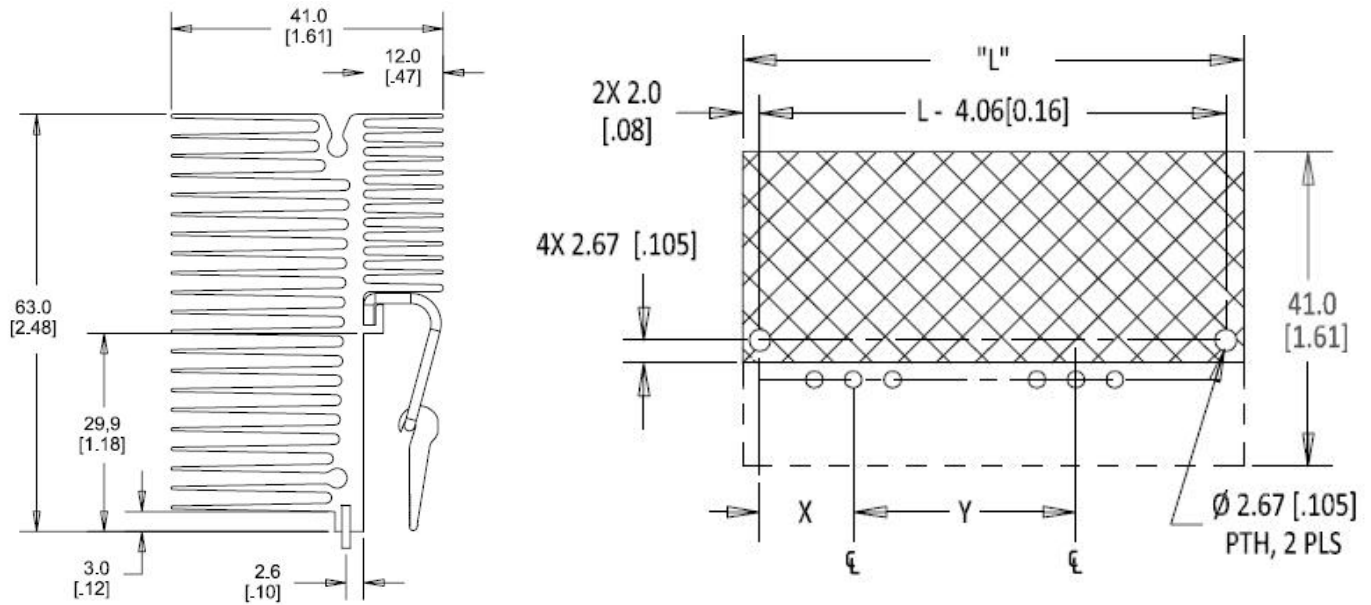



### Clips

Part Number	Description
OMNI-UC	Universal Clip for OmniKlip Heat Sink for any TO except T0220
OMNI-220C	Clip for OmniKlip Heat Sink for TO 220

Universal Clip mechanism is rotating the bar by 180°. The eccentric circle will raise 0.09". This deformation will exert the force on the components.

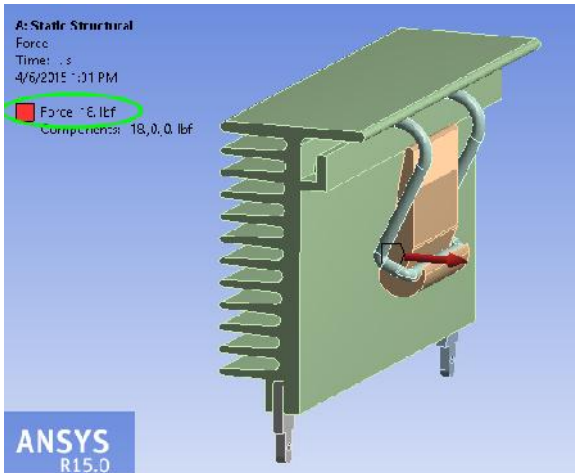
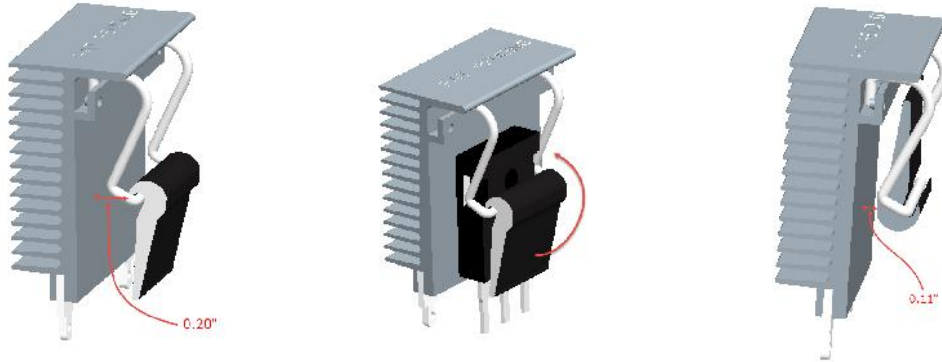

omniKlip assembly model in ANSYS, with 18 lbf load applied to the clip

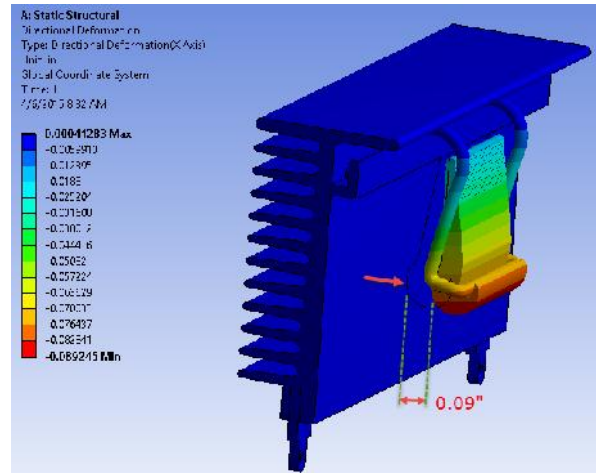

Under the 18 lbf, the clip deformed 0.09" from its original position to the final

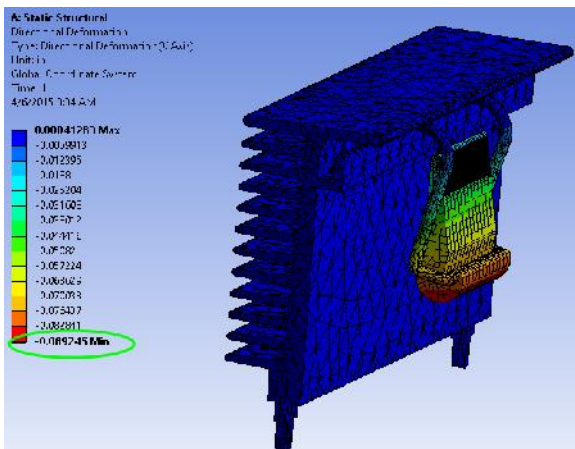

Directional deformation plot as shown

With the FEA analysis and simulation, the force applied to the TO-series components will be at least 18 lbs.

**Additional Configurations**

**Contact Wakefield-Vette for more information or visit [www.wakefield-vette.com](http://www.wakefield-vette.com)**

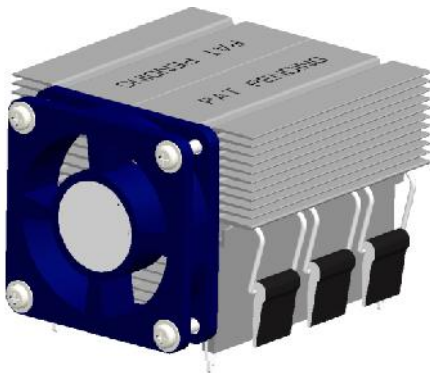

Back to Back Mounting with 60mm Fan  
(OMNI-UNI-41-L Series Heat Sink)

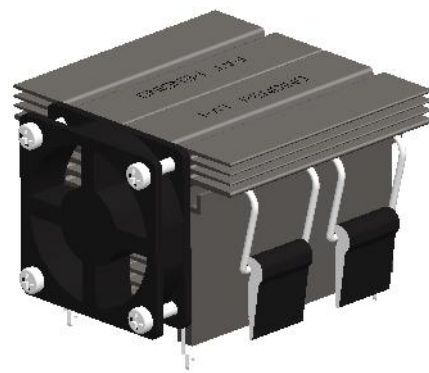

Back to Back Mounting with 40mm Fan  
(OMNI-UNI-32-L Series Heat Sink)

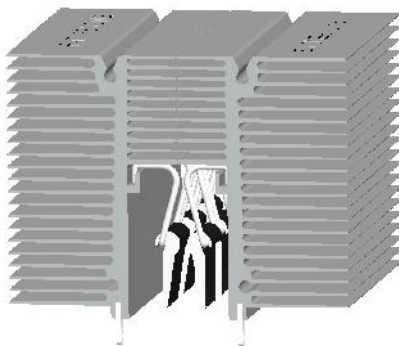

Face to Face Mounting (Space Saver)  
(OMNI-UNI-41-L Series Heat Sink)

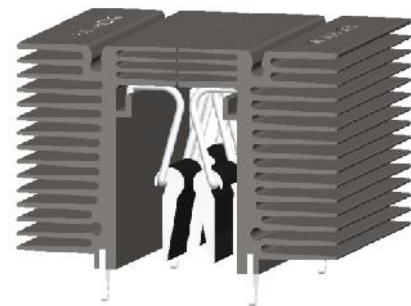

Face to Face Mounting (Space Saver)  
(OMNI-UNI-32-L Series Heat Sink)