



Chipsmall Limited consists of a professional team with an average of over 10 year of expertise in the distribution of electronic components. Based in Hongkong, we have already established firm and mutual-benefit business relationships with customers from,Europe,America and south Asia,supplying obsolete and hard-to-find components to meet their specific needs.

With the principle of “Quality Parts,Customers Priority,Honest Operation,and Considerate Service”,our business mainly focus on the distribution of electronic components. Line cards we deal with include Microchip,ALPS,ROHM,Xilinx,Pulse,ON,Everlight and Freescale. Main products comprise IC,Modules,Potentiometer,IC Socket,Relay,Connector.Our parts cover such applications as commercial,industrial, and automotives areas.

We are looking forward to setting up business relationship with you and hope to provide you with the best service and solution. Let us make a better world for our industry!



Contact us

Tel: +86-755-8981 8866 Fax: +86-755-8427 6832

Email & Skype: info@chipsmall.com Web: www.chipsmall.com

Address: A1208, Overseas Decoration Building, #122 Zhenhua RD., Futian, Shenzhen, China



Infrared Light Emitting Diode in 1210 SMD Package OP225



- 850nm Wavelength
- Narrow Beam Angle
- High Power
- Water Clear dome lensed
- EIA Standard Package

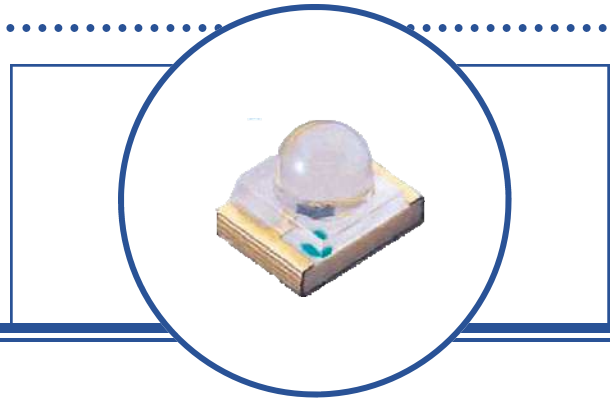

Description:

The OP225 is a GaAlAs infrared LED mounted in an SMT package. The OP225 incorporates an integral molded lens which enables a narrow beam angle and provides an even emission pattern. The narrow irradiance pattern provides high on-axis intensity for excellent coupling efficiency. The OP225 LED is mechanically and spectrally matched to the OP525 series photosensors. The package is compatible with most automated mounting equipment.

Applications

- Non-Contact Position Sensing
- Datum detection
- Machine automation
- Light curtains
- Counters
- Optical encoders
- IrDA
- Reflective and Transmissive Sensors

Relative Radiant Intensity vs.
Angular Displacement

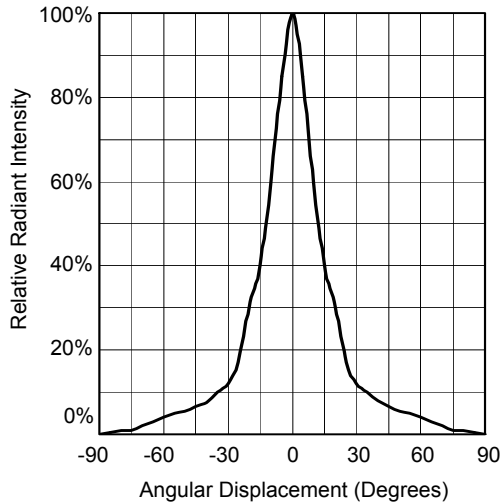

Package Dimension

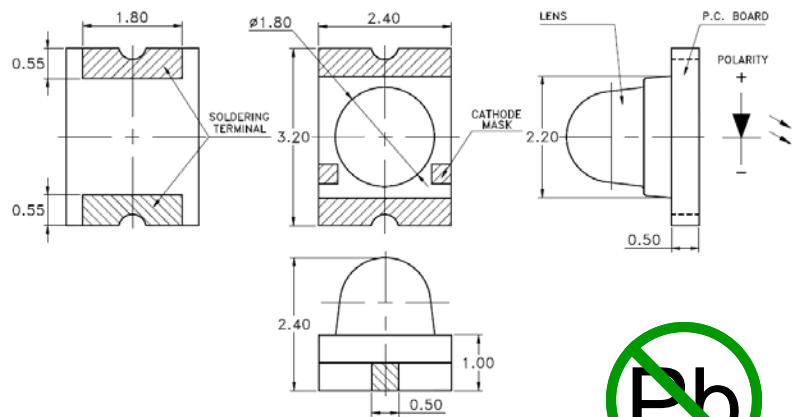

Dimensions in mm



RoHS



OPTEK reserves the right to make changes at any time in order to improve design and to supply the best product possible.

Infrared Light Emitting Diode in 1210 SMD Package OP225



Absolute Maximum Ratings ($T_A = 25^\circ\text{C}$ unless otherwise noted)

PARAMETER	SYMBOL	MAXIMUM	UNITS
Continuous Forward Current	I_F	50	mA
Power Dissipation	P_d	75	mW
Reverse Voltage	I_R	5	V
Peak Forward Current (1 μs pulse width, 300 pps)	I_{FP}	1	A
Lead Soldering Temperature (1.6mm to epoxy for 5 sec.)	T_{SOL}	260°	C
Operating Temperature Range	T_{OPR}	-40°C to +85°C	
Storage Temperature Range	T_{STG}	-55°C to +85°C	

Notes:

- Solder time less than 5 seconds at temperature extreme.
- De-rate linearly at 2.17 mW/°C above 25°C.

Electrical Characteristics ($T_A = 25^\circ\text{C}$ unless otherwise noted)

SYMBOL	PARAMETER	MIN	TYP	MAX	UNITS	CONDITIONS
E_e	Radiant Intensity	20	45		mW/sr	$I_F = 100\text{mA}$ (300pps, 10us pulse)
V_F	Forward Voltage	1.30	1.45	1.65	V	$I_F = 20\text{mA}$
I_R	Reverse Current			10	μA	$V_R = 5.0\text{V}$
λ_P	Peak Emission Wavelength		850		nm	$I_F = 10\text{mA}$
Θ_{HP}	Emission Angle at Half Power Points		20		Deg.	$I_F = 20\text{mA}$
t_r, t_f	Rise and Fall Time		30		ns	$I_{F(PK)} = 100\text{mA}$, PW = 10 μs , 10% D.C.

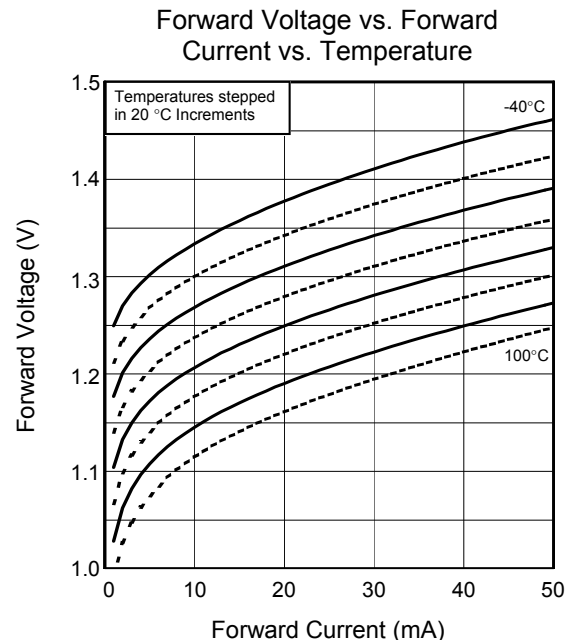
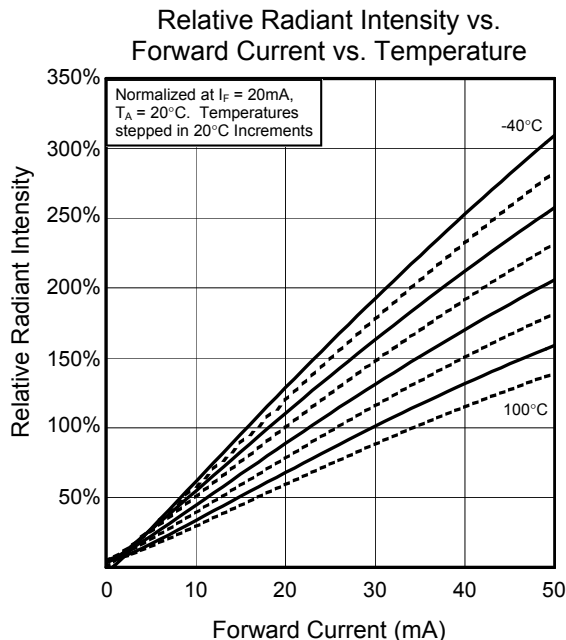

OPTEK reserves the right to make changes at any time in order to improve design and to supply the best product possible.

