



Chipsmall Limited consists of a professional team with an average of over 10 year of expertise in the distribution of electronic components. Based in Hongkong, we have already established firm and mutual-benefit business relationships with customers from,Europe,America and south Asia,supplying obsolete and hard-to-find components to meet their specific needs.

With the principle of "Quality Parts,Customers Priority,Honest Operation,and Considerate Service",our business mainly focus on the distribution of electronic components. Line cards we deal with include Microchip,ALPS,ROHM,Xilinx,Pulse,ON,Everlight and Freescale. Main products comprise IC,Modules,Potentiometer,IC Socket,Relay,Connector.Our parts cover such applications as commercial,industrial, and automotives areas.

We are looking forward to setting up business relationship with you and hope to provide you with the best service and solution. Let us make a better world for our industry!



Contact us

Tel: +86-755-8981 8866 Fax: +86-755-8427 6832

Email & Skype: info@chipsmall.com Web: www.chipsmall.com

Address: A1208, Overseas Decoration Building, #122 Zhenhua RD., Futian, Shenzhen, China



FEATURES

- Low offset voltage: 75 μV maximum
- Low offset voltage drift: 1.0 $\mu\text{V}/^\circ\text{C}$ maximum
- Very low bias current
- 25°C: 150 pA maximum
- 40°C to +85°C: 300 pA maximum
- Very high open-loop gain: 2000 V/mV minimum
- Low supply current (per amplifier): 625 μA maximum
- Operates from $\pm 2\text{ V}$ to $\pm 20\text{ V}$ supplies
- High common-mode rejection: 114 dB minimum

APPLICATIONS

- Strain gage and bridge amplifiers
- High stability thermocouple amplifiers
- Instrumentation amplifiers
- Photocurrent monitors
- High gain linearity amplifiers
- Long-term integrators/filters
- Sample-and-hold amplifiers
- Peak detectors
- Logarithmic amplifiers
- Battery-powered systems

GENERAL DESCRIPTION

The OP497 is a quad op amp with precision performance in the space-saving, industry standard 16-lead SOIC package. Its combination of exceptional precision with low power and extremely low input bias current makes the quad OP497 useful in a wide variety of applications.

Precision performance of the OP497 includes very low offset ($<50\ \mu\text{V}$) and low drift ($<0.5\ \mu\text{V}/^\circ\text{C}$). Open-loop gain exceeds 2000 V/mV ensuring high linearity in every application. Errors due to common-mode signals are eliminated by its common-mode rejection of $>120\ \text{dB}$. The OP497 has a power supply rejection of $>120\ \text{dB}$ which minimizes offset voltage changes experienced in battery-powered systems. The supply current of the OP497 is $<625\ \mu\text{A}$ per amplifier, and it can operate with supply voltages as low as $\pm 2\text{ V}$.

The OP497 uses a superbeta input stage with bias current cancellation to maintain picoamp bias currents at all temperatures. This is in contrast to FET input op amps whose bias currents start in the picoamp range at 25°C but double for every 10°C rise in temperature to reach the nanoamp range above 85°C. The input bias current of the OP497 is $<100\ \text{pA}$ at 25°C.

Rev. E

Information furnished by Analog Devices is believed to be accurate and reliable. However, no responsibility is assumed by Analog Devices for its use, nor for any infringements of patents or other rights of third parties that may result from its use. Specifications subject to change without notice. No license is granted by implication or otherwise under any patent or patent rights of Analog Devices. Trademarks and registered trademarks are the property of their respective owners.

PIN CONNECTIONS

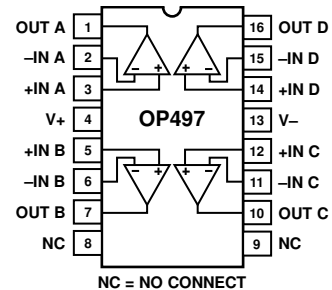

Figure 1. 16-Lead Wide Body SOIC (RW-16)

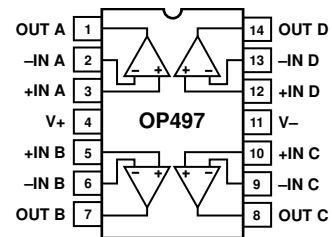

Figure 2. 14-Lead PDIP (N-14)

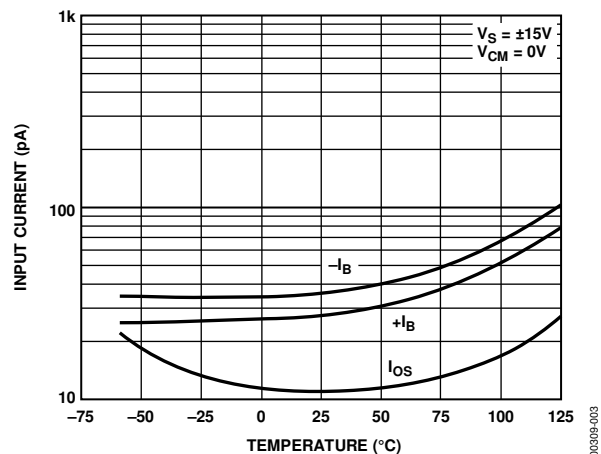

Figure 3. Input Bias, Offset Current vs. Temperature

Combining precision, low power, and low bias current, the OP497 is ideal for a number of applications, including instrumentation amplifiers, log amplifiers, photodiode preamplifiers, and long-term integrators. For a single device, see the [OP97](#) data sheet, and for a dual device, see the [OP297](#) data sheet.

OP497* PRODUCT PAGE QUICK LINKS

Last Content Update: 02/23/2017

COMPARABLE PARTS

View a parametric search of comparable parts.

DOCUMENTATION

Application Notes

- AN-649: Using the Analog Devices Active Filter Design Tool

Data Sheet

- OP497: Military Data Sheet
- OP497: Precision Picoampere Input Current Quad Operational Amplifier Data Sheet

TOOLS AND SIMULATIONS

- Analog Filter Wizard
- Analog Photodiode Wizard
- OP497 SPICE Macro-Model

DESIGN RESOURCES

- OP497 Material Declaration
- PCN-PDN Information
- Quality And Reliability
- Symbols and Footprints

DISCUSSIONS

View all OP497 EngineerZone Discussions.

SAMPLE AND BUY

Visit the product page to see pricing options.

TECHNICAL SUPPORT

Submit a technical question or find your regional support number.

DOCUMENT FEEDBACK

Submit feedback for this data sheet.

TABLE OF CONTENTS

Features	1	AC Performance	10
Applications.....	1	Guarding And Shielding	11
General Description	1	Open-Loop Gain Linearity	11
Pin Connections	1	Applications Circuit	12
Revision History	2	Precision Absolute Value Amplifier.....	12
Specifications.....	3	Precision Current Pump.....	12
Absolute Maximum Ratings.....	4	Precision Positive Peak Detector.....	12
Thermal Resistance	4	Simple Bridge Conditioning Amplifier	12
ESD Caution.....	4	Nonlinear Circuits.....	13
Typical Performance Characteristics	5	Outline Dimensions	14
Applications Information	10	Ordering Guide	15

REVISION HISTORY

2/09—Rev. D to Rev. E

Deleted 14-Lead CERDIP.....	Throughout
Changes to Features Section and General Description Section.....	1
Delete Military Processed Devices Text, SMD Part Number, ADI Part Number Table, and Dice Characteristics Figure	3
Changes to Table 1.....	3
Changes to Absolute Maximum Ratings Section	4
Changes to Figure 12.....	6
Changes to Figure 18 and Figure 19.....	7
Changes to Figure 26 and Figure 28.....	8
Deleted OP497 Spice Macro-Model Section.....	10
Changes to Applications Information Section.....	10
Moved Figure 33	10
Deleted Table I. OP497 SPICE Net-List.....	11
Changes to Open-Loop Gain Linearity Section and Figure 35	11
Changes to Figure 40.....	13
Updated Outline Dimensions	14
Changes to Ordering Guide	15

11/01—Rev. C to Rev. D

Edits to Pin Connection Headings.....	1
Deleted Wafer Test Limits	3
Edits to Absolute Maximum Ratings	5
Edits to Outline Dimensions.....	16
Edits to Ordering Guide	17

SPECIFICATIONS

T_A = 25°C, V_S = ±15 V, unless otherwise noted.

Table 1.

Parameter	Symbol	Condition	F Grade			G Grade			Unit
			Min	Typ	Max	Min	Typ	Max	
INPUT CHARACTERISTICS									
Offset Voltage	V _{OS}		40	75		80	150		μV
		-40°C ≤ +85°C	70	150		120	250		μV
Average Input Offset Voltage Drift	TCV _{OS}	T _{MIN} - T _{MAX}	0.4	1.0		0.6	1.5		μV/°C
Long-Term Input Offset Voltage Stability			0.1			0.1			μV/Month
Input Bias Current	I _B	V _{CM} = 0 V	40	150		60	200		pA
		-40° ≤ T _A ≤ +85°C	60	200		80	300		pA
Average Input Bias Current Drift	TC _{IB}	-40° ≤ T _A ≤ +85°C	0.3			0.3			pA/°C
Input Offset Current	I _{OS}	V _{CM} = 0 V	30	150		50	200		pA
		-40° ≤ T _A ≤ +85°C	50	200		80	300		pA
Average Input Offset Current Drift	T _{CIOS}		0.3			0.4			pA/°C
Input Voltage Range ¹	IVR		±13	±14		±13	±14		V
		T _{MIN} - T _{MAX}	±13	±13.5		±13	±13.5		V
Common-Mode Rejection	CMR	V _{CM} = ±13 V	114	135		114	135		dB
		T _{MIN} - T _{MAX}	108	120		108	120		dB
Large Signal Voltage Gain	A _{VO}	V _O = ±10 V, R _L = 2 kΩ	1500	4000		1200	4000		V/mV
		-40° ≤ T _A ≤ +85°C	800	2000		800	2000		V/mV
Input Resistance Differential Mode	R _{IN}		30			30			MΩ
Input Resistance Common Mode	R _{INCM}		500			500			GΩ
Input Capacitance	C _{IN}		3			3			pF
OUTPUT CHARACTERISTICS									
Output Voltage Swing	V _O	R _L = 2 kΩ	±13	±13.7		±13	±13.7		V
		R _L = 10 kΩ, T _{MIN} - T _{MAX}	±13	±14		±13	±14		V
		R _L = 10 kΩ	±13	±13.5		±13	±13.5		V
Short Circuit	I _{SC}			±25			±25		mA
POWER SUPPLY									
Power Supply Rejection Ratio	PSRR	V _S = ±2 V to ±20 V	114	135		114	135		dB
		V _S = ±2.5 V to ±20 V, T _{MIN} - T _{MAX}	108	120		108	120		dB
Supply Current (per Amplifier)	I _{SY}	No load		525	625		525	625	μA
		T _{MIN} - T _{MAX}		580	750		580	750	μA
Supply Voltage Range	V _S	Operating range	±2		±20	±2		±20	V
		T _{MIN} - T _{MAX}	±2.5		±20	±2.5		±20	V
DYNAMIC PERFORMANCE									
Slew Rate	SR		0.05	0.15		0.05	0.15		V/μs
Gain Bandwidth Product	GBW			500			500		kHz
Channel Separation	CS	V _O = 20 V p-p, f ₀ = 10 Hz		150			150		dB
NOISE PERFORMANCE									
Voltage Noise	e _n p-p	0.1 Hz to 10 Hz		0.3			0.3		μV/p-p
Voltage Noise Density	e _n	e _n = 10 Hz		17			17		nV/√Hz
		e _n = 1 kHz		15			15		nV/√Hz
Current Noise Density	i _n	i _n = 10 Hz		20			20		fA/√Hz

¹ Guaranteed by CMR test.

OP497

ABSOLUTE MAXIMUM RATINGS

Absolute maximum ratings apply to packaged parts.

Table 2.

Parameter	Rating
Supply Voltage	±20 V
Input Voltage ¹	20 V
Differential Input Voltage ¹	40 V
Output Short-Circuit Duration	Indefinite
Storage Temperature Range	−65°C to +150°C
Operating Temperature Range	−40°C to +85°C
Junction Temperature Range	−65°C to +150°C
Lead Temperature (Soldering, 60 sec)	300°C

¹For supply voltages less than ±20 V, the absolute maximum input voltage is equal to the supply voltage.

Stresses above those listed under Absolute Maximum Ratings may cause permanent damage to the device. This is a stress rating only; functional operation of the device at these or any other conditions above those indicated in the operational section of this specification is not implied. Exposure to absolute maximum rating conditions for extended periods may affect device reliability.

THERMAL RESISTANCE

θ_{JA} is specified for the worst-case mounting conditions, that is, θ_{JA} is specified for a device in socket for the PDIP package, and θ_{JA} is specified for a device soldered to the printed circuit board (PCB) for the SOIC package.

Table 3.

Package Type	θ_{JA}	θ_{JC}	Unit
14-Lead PDIP (N-14)	76	33	°C/W
16-Lead SOIC (RW-16)	92	23	°C/W

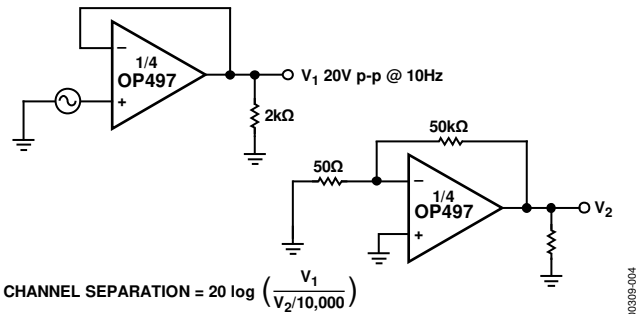

Figure 4. Channel Separation Test Circuit

ESD CAUTION



ESD (electrostatic discharge) sensitive device. Charged devices and circuit boards can discharge without detection. Although this product features patented or proprietary protection circuitry, damage may occur on devices subjected to high energy ESD. Therefore, proper ESD precautions should be taken to avoid performance degradation or loss of functionality.

TYPICAL PERFORMANCE CHARACTERISTICS

$T_A = 25^\circ\text{C}$, $V_S = \pm 15\text{ V}$, unless otherwise noted.

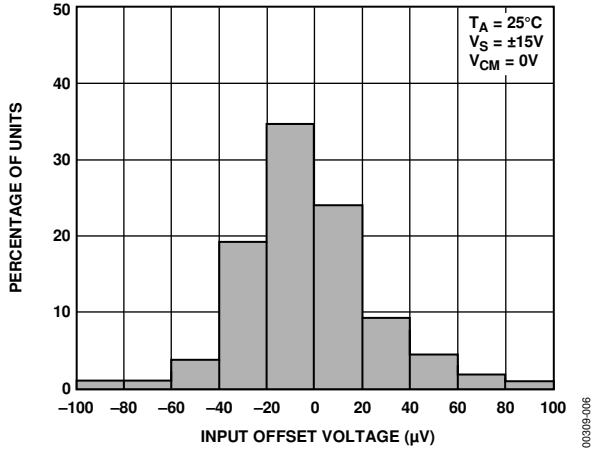

Figure 5. Typical Distribution of Input Offset Voltage

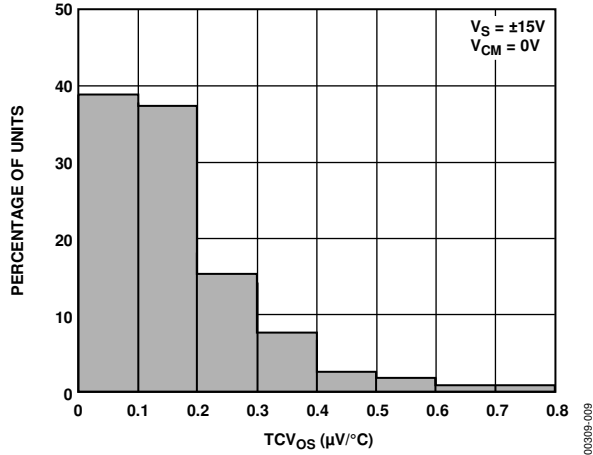

Figure 8. Typical Distribution of TCV_{OS}

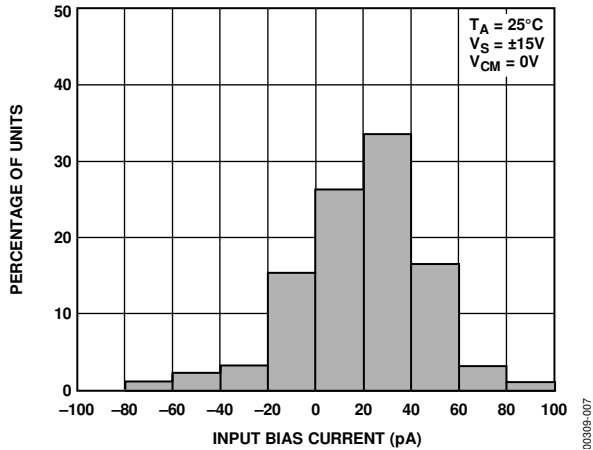

Figure 6. Typical Distribution of Input Bias Current

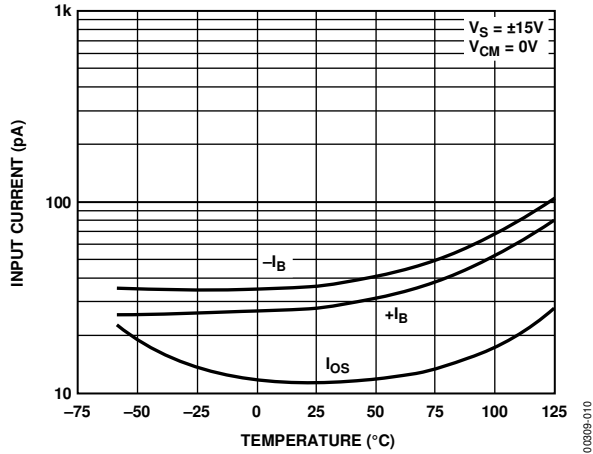

Figure 9. Input Bias, Offset Current vs. Temperature

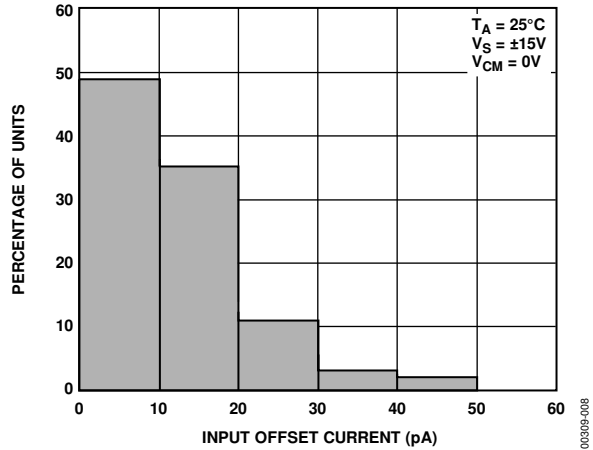

Figure 7. Typical Distribution of Input Offset Current

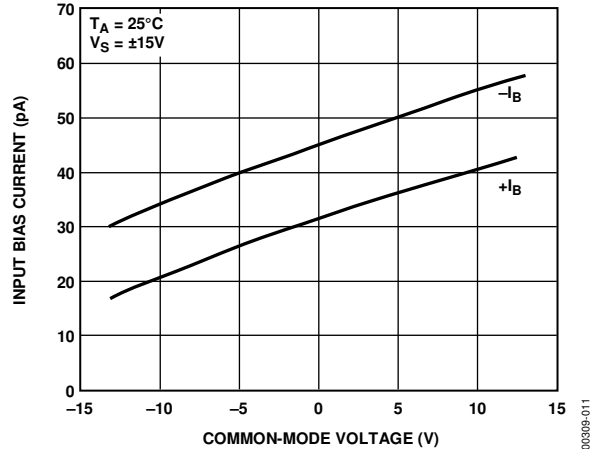

Figure 10. Input Bias Current vs. Common-Mode Voltage

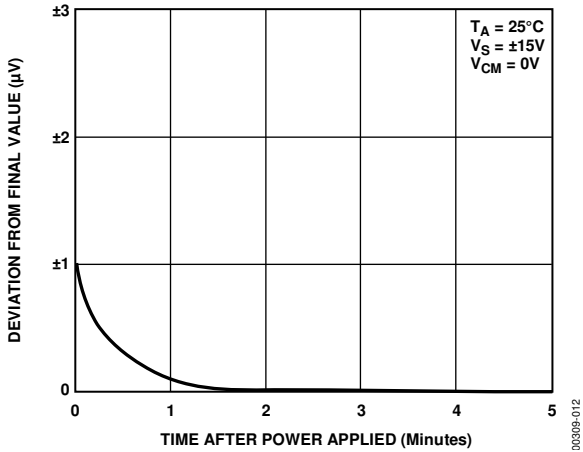

Figure 11. Input Offset Voltage Warm-Up Drift

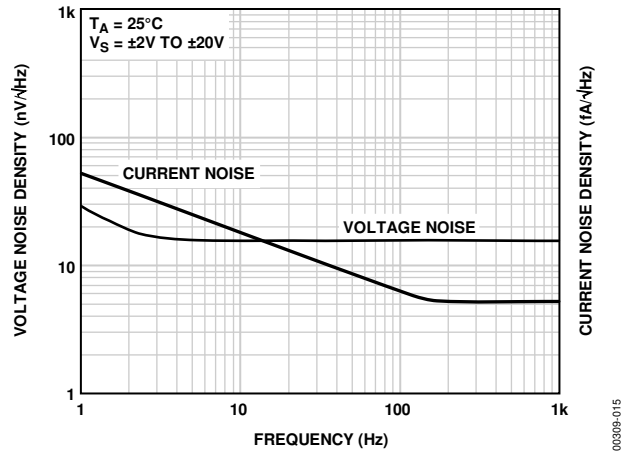

Figure 14. Voltage Noise Density vs. Frequency

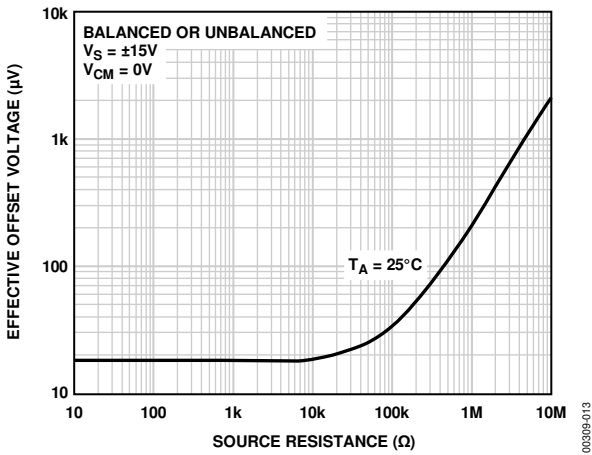

Figure 12. Effective Offset Voltage vs. Source Resistance

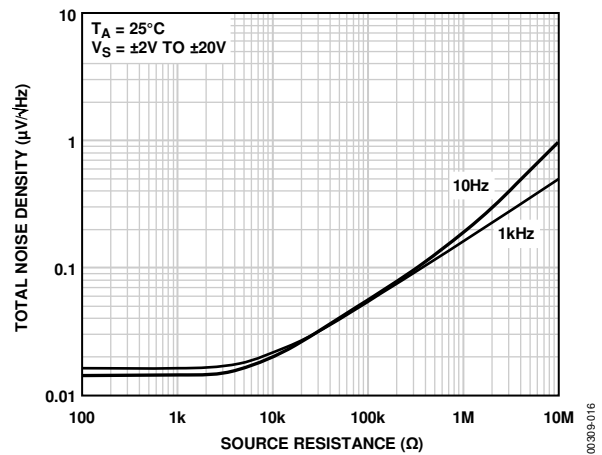

Figure 15. Total Noise Density vs. Source Resistance

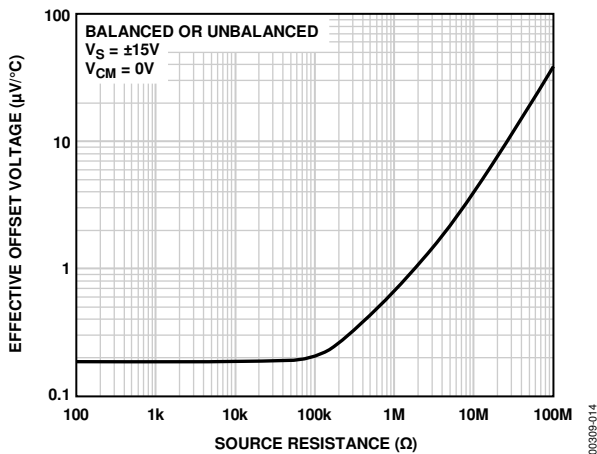

Figure 13. Effective TCV_{05} vs. Source Resistance

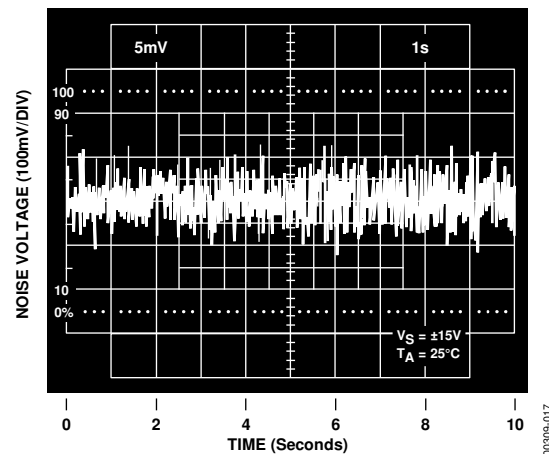

Figure 16. 0.1 Hz to 10 Hz Noise Voltage

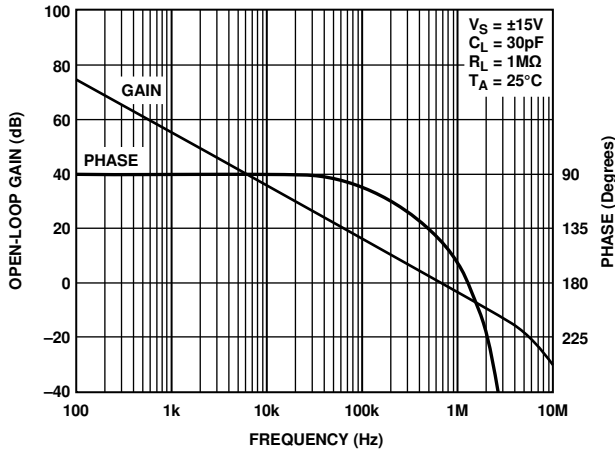

Figure 17. Open-Loop Gain and Phase vs. Frequency

00309-018

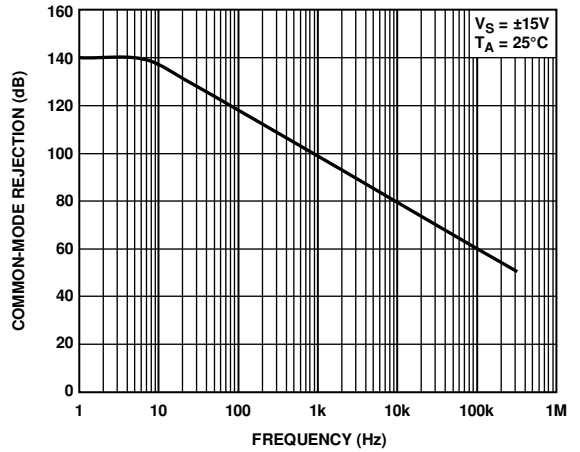

Figure 20. Common-Mode Rejection vs. Frequency

00309-021

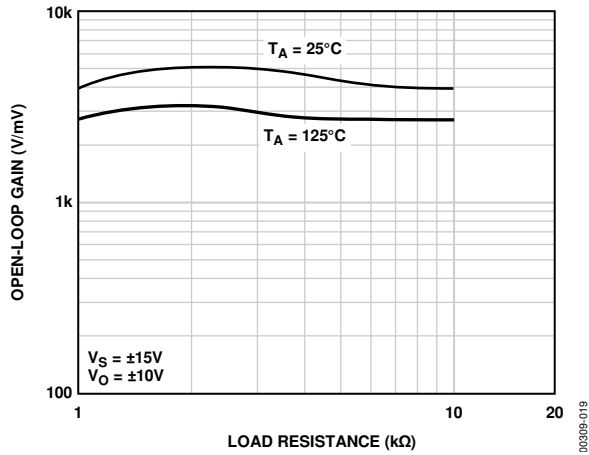

Figure 18. Open-Loop Gain vs. Load Resistance

00309-019

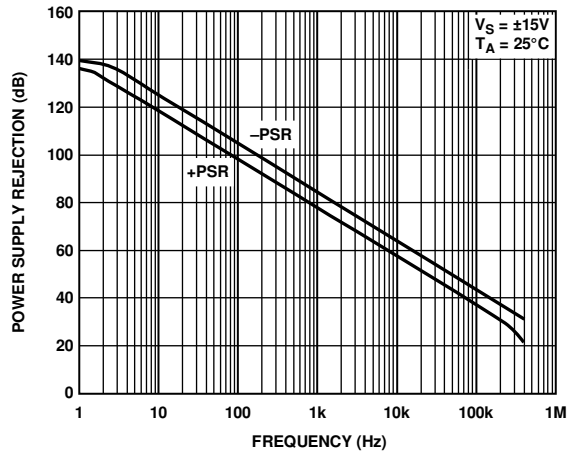

Figure 21. Power Supply Rejection vs. Frequency

00309-022

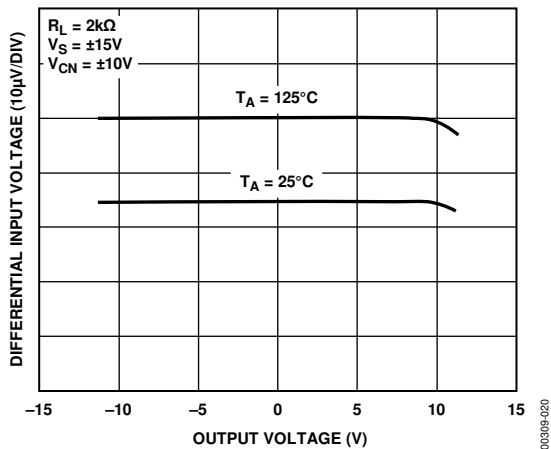

Figure 19. Open-Loop Gain Linearity

00309-020

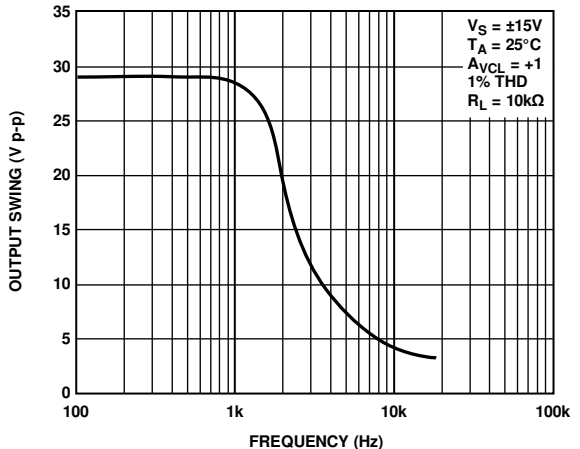

Figure 22. Maximum Output Swing vs. Frequency

00309-023

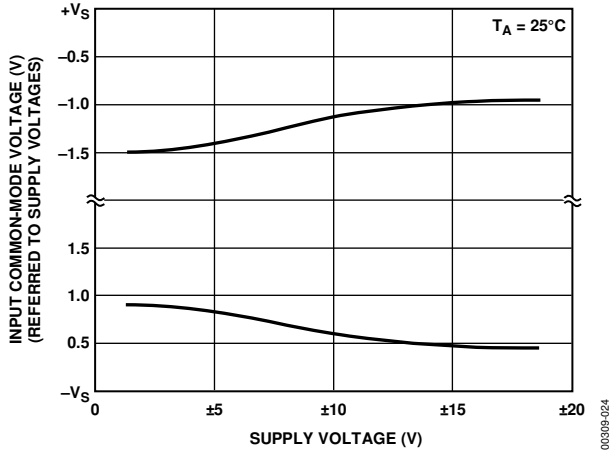

Figure 23. Input Common-Mode Voltage Range vs. Supply Voltage

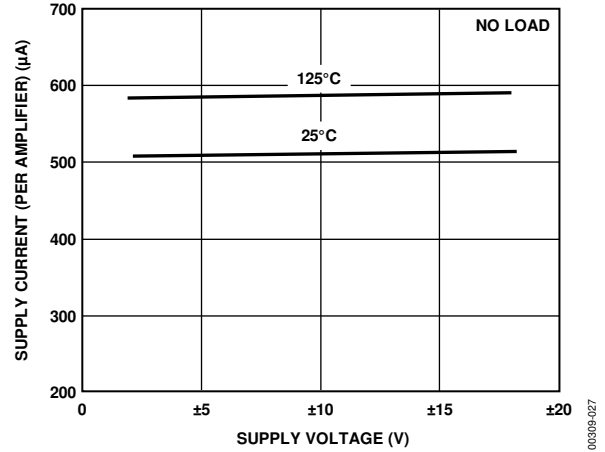

Figure 26. Supply Current (per Amplifier) vs. Supply Voltage

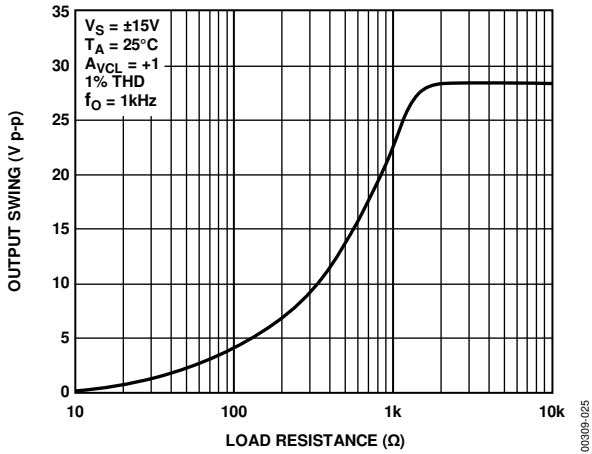

Figure 24. Maximum Output Swing vs. Load Resistance

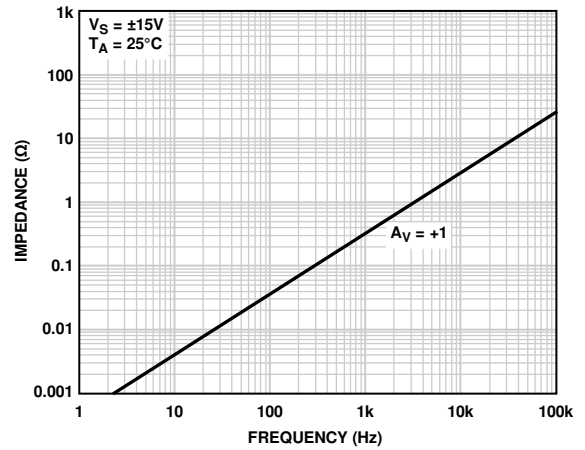

Figure 27. Closed-Loop Output Impedance vs. Frequency

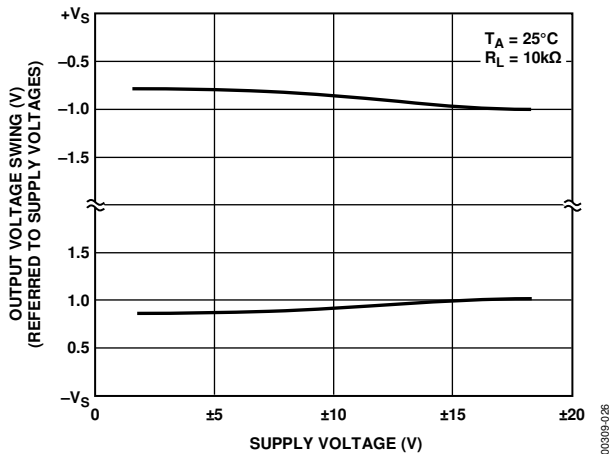

Figure 25. Output Voltage Swing vs. Supply Voltage

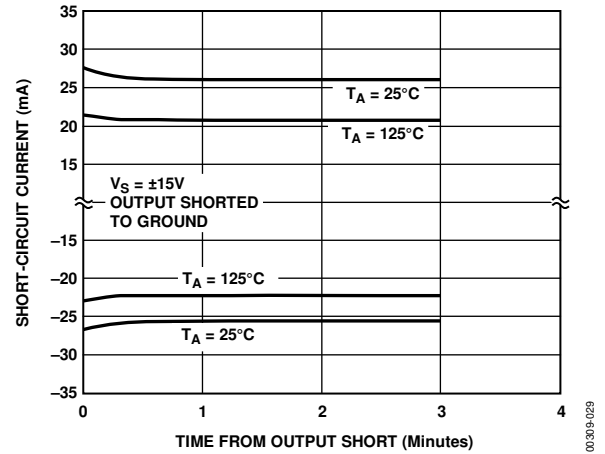

Figure 28. Short-Circuit Current vs. Time at Various Temperatures

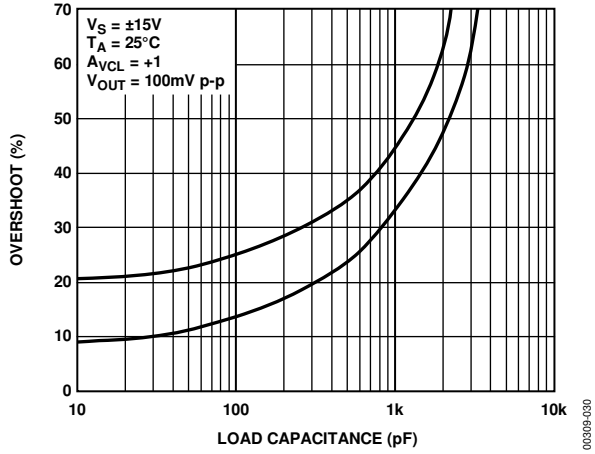

Figure 29. Small-Signal Overshoot vs. Load Capacitance

APPLICATIONS INFORMATION

Extremely low bias current makes the OP497 attractive for use in sample-and-hold amplifiers, peak detectors, and log amplifiers that must operate over a wide temperature range. Balancing input resistances is not necessary with the OP497. High source resistance, even when unbalanced, only minimally degrades the offset voltage and TCV_{os} .

The input pins of the OP497 are protected against large differential voltage by back-to-back diodes and current-limiting resistors. Common-mode voltages at the inputs are not restricted and may vary over the full range of the supply voltages used.

The OP497 requires very little operating headroom about the supply rails and is specified for operation with supplies as low as ± 2 V. Typically, the common-mode range extends to within 1 V of either rail. When using a 10 k Ω load, the output typically swings to within 1 V of the rails.

AC PERFORMANCE

The ac characteristics of the OP497 are highly stable over its full operating temperature range. Figure 30 shows the unity-gain small signal response. Extremely tolerant of capacitive loading on the output, the OP497 displays excellent response even with 1000 pF loads (see Figure 31).

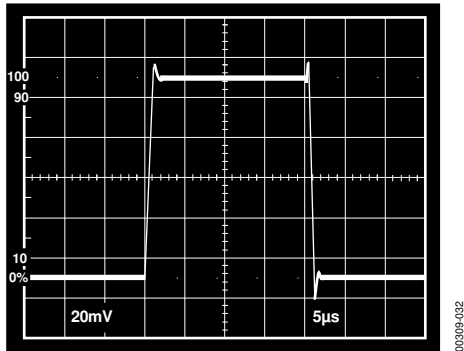

Figure 30. Small Signal Transient Response ($C_{LOAD} = 100$ pF, $A_{VCL} = +1$)

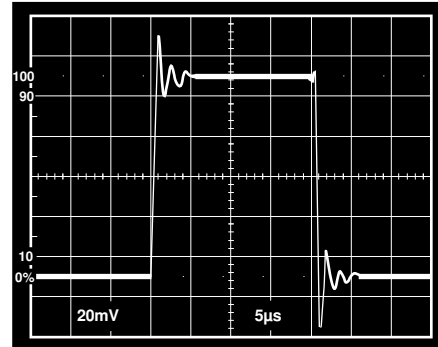

Figure 31. Small Signal Transient Response ($C_{LOAD} = 1000$ pF, $A_{VCL} = +1$)

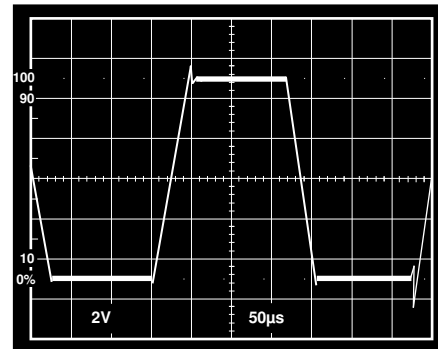

Figure 32. Large Signal Transient Response ($A_{VCL} = +1$)

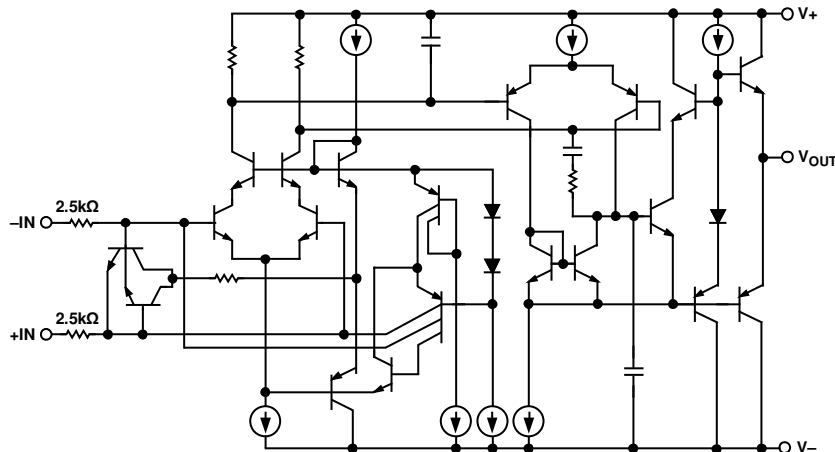

Figure 33. Simplified Schematic Showing One Amplifier

GUARDING AND SHIELDING

To maintain the extremely high input impedances of the OP497, care must be taken in circuit board layout and manufacturing. Board surfaces must be kept scrupulously clean and free of moisture. Conformal coating is recommended to provide a humidity barrier. Even a clean PCB can have 100 pA of leakage currents between adjacent traces; therefore, use guard rings around the inputs. Guard traces are operated at a voltage close to that on the inputs, as shown in Figure 34, so that leakage currents become minimal. In noninverting applications, connect the guard ring to the common-mode voltage at the inverting input. In inverting applications, both inputs remain at ground; therefore, the guard trace should be grounded. Place guard traces on both sides of the circuit board.

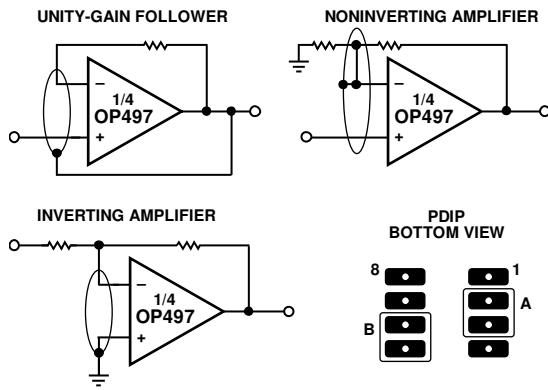

Figure 34. Guard Ring Layout and Connections

OPEN-LOOP GAIN LINEARITY

The OP497 has both an extremely high gain of 2000 V/mV typical and constant gain linearity. This enhances the precision of the OP497 and provides for very high accuracy in high closed-loop gain applications. Figure 35 illustrates the typical open-loop gain linearity of the OP497.

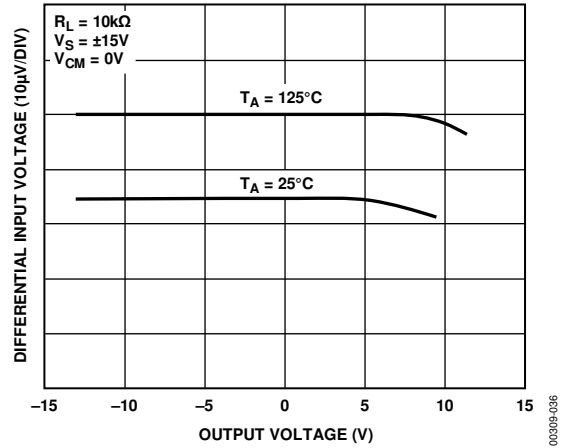

Figure 35. Open-Loop Gain Linearity

APPLICATIONS CIRCUIT

PRECISION ABSOLUTE VALUE AMPLIFIER

The circuit in Figure 36 is a precision absolute value amplifier with an input impedance of 30 M Ω . The high gain and low TC V_{OS} of the OP497 ensure accurate operation with microvolt input signals. In this circuit, the input always appears as a common-mode signal to the op amps. The CMR of the OP497 exceeds 120 dB, yielding an error of less than 2 ppm.

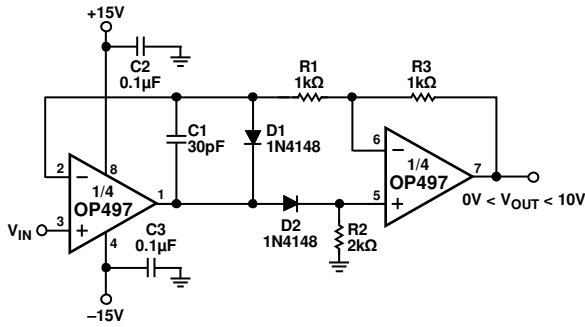

Figure 36. Precision Absolute Value Amplifier

PRECISION CURRENT PUMP

Maximum output current of the precision current pump shown in Figure 37 is ± 10 mA. Voltage compliance is ± 10 V with ± 15 V supplies. Output impedance of the current transmitter exceeds 3 M Ω with linearity better than 16 bits.

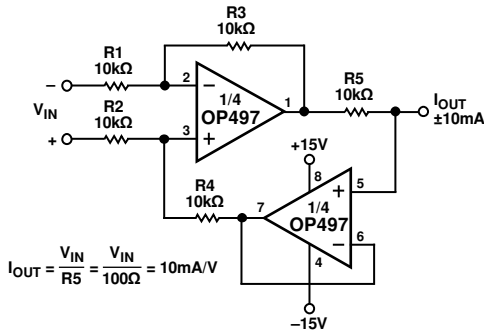

Figure 37. Precision Current Pump

PRECISION POSITIVE PEAK DETECTOR

In Figure 38, the C_H must be of polystyrene, Teflon[®], or polyethylene to minimize dielectric absorption and leakage. The droop rate is determined by the size of C_H and the bias current of the OP497.

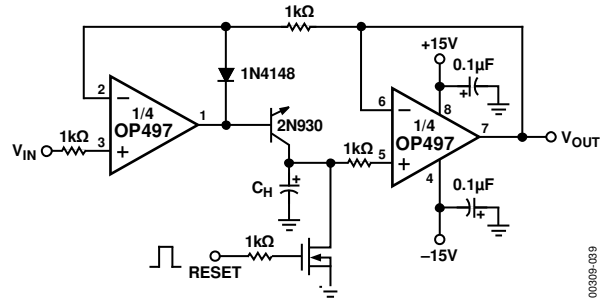

Figure 38. Precision Positive Peak Detector

SIMPLE BRIDGE CONDITIONING AMPLIFIER

Figure 39 shows a simple bridge conditioning amplifier using the OP497. The transfer function is

$$V_{OUT} = V_{REF} \left(\frac{\Delta R}{R + \Delta R} \right) \frac{R_F}{R}$$

The REF43 provides an accurate and stable reference voltage for the bridge. To maintain the highest circuit accuracy, R_F should be 0.1% or better with a low temperature coefficient.

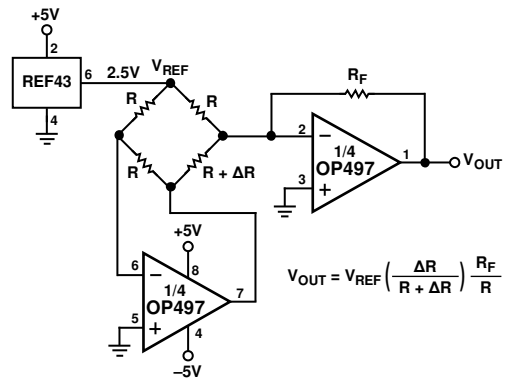

Figure 39. Simple Bridge Conditioning Amplifier Using the OP497

NONLINEAR CIRCUITS

Due to its low input bias currents, the OP497 is an ideal log amplifier in nonlinear circuits, such as the squaring amplifier and square root amplifier circuits shown in Figure 40 and Figure 41. Using the squaring amplifier circuit in Figure 40 as an example, the analysis begins by writing a voltage loop equation across Transistors Q1, Q2, Q3, and Q4.

$$V_{T1} I_n \left(\frac{I_{IN}}{I_{S1}} \right) + V_{T2} I_n \left(\frac{I_{IN}}{I_{S2}} \right) = V_{T3} I_n \left(\frac{I_{O}}{I_{S3}} \right) + V_{T4} I_n \left(\frac{I_{REF}}{I_{S4}} \right)$$

All the transistors in the MAT04 are precisely matched and at the same temperature; therefore, the I_S and V_T terms cancel, giving

$$2InI_{IN} = InI_{O} + InI_{REF} = In (I_{O} \times I_{REF})$$

Exponentiating both sides of the thick equation lead to

$$I_{O} = \frac{(I_{IN})^2}{I_{REF}}$$

Op amp A2 forms a current-to-voltage converter which results in $V_{OUT} = R2 \times I_{O}$. Substituting $(V_{IN}/R1)$ for I_{IN} and the previous equation for I_{O} yields

$$V_{OUT} = \left(\frac{R2}{I_{REF}} \right) \left(\frac{V_{IN}}{R1} \right)^2$$

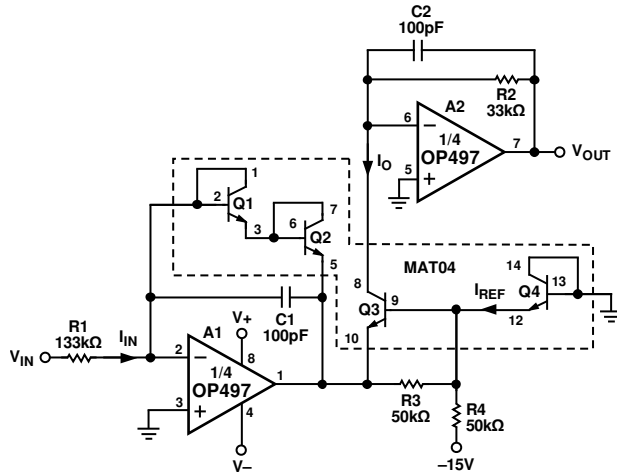

Figure 40. Squaring Amplifier

A similar analysis made for the square root amplifier circuit in Figure 41 leads to its transfer function

$$V_{OUT} = R2 \sqrt{\frac{(V_{IN})(I_{REF})}{R1}}$$

In these circuits, I_{REF} is a function of the negative power supply. To maintain accuracy, the negative supply should be well regulated. For applications where very high accuracy is required, a voltage reference can be used to set I_{REF} . An important consideration for the squaring circuit is that a sufficiently large input voltage can force the output beyond the operating range of the output op amp. Resistor R4 can be changed to scale I_{REF} , or R1 and R2 can be varied to keep the output voltage within the usable range.

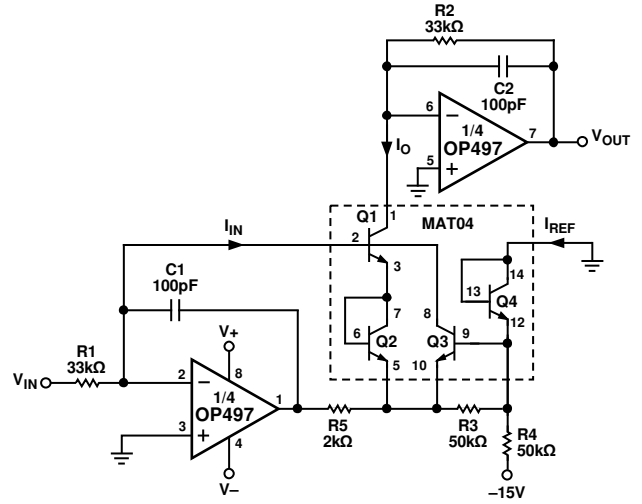
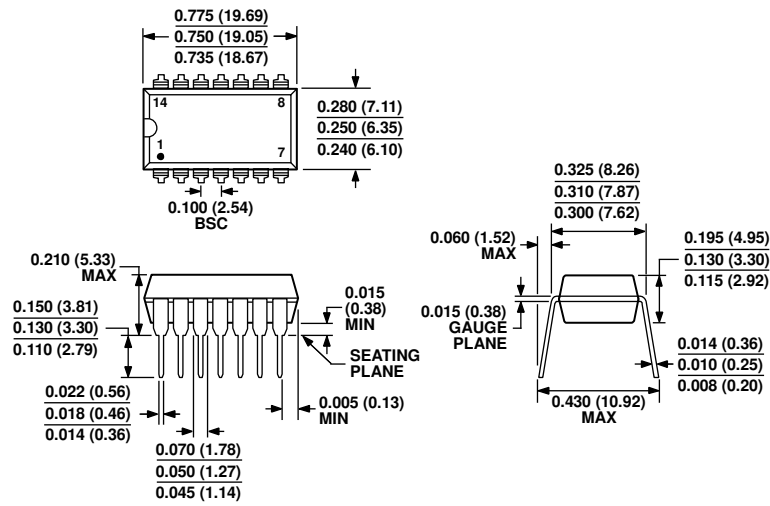

Figure 41. Square Root Amplifier

Unadjusted accuracy of the square root circuit is better than 0.1% over an input voltage range of 100 mV to 10 V. For a similar input voltage range, the accuracy of the squaring circuit is better than 0.5%.

OUTLINE DIMENSIONS



COMPLIANT TO JEDEC STANDARDS MS-001
 CONTROLLING DIMENSIONS ARE IN INCHES; MILLIMETER DIMENSIONS (IN PARENTHESES) ARE ROUNDED-OFF INCH EQUIVALENTS FOR REFERENCE ONLY AND ARE NOT APPROPRIATE FOR USE IN DESIGN. CORNER LEADS MAY BE CONFIGURED AS WHOLE OR HALF LEADS.

Figure 42. 14-Lead Plastic Dual In-Line Package [PDIP] Narrow Body (N-14)

Dimensions shown in inches and (millimeters)

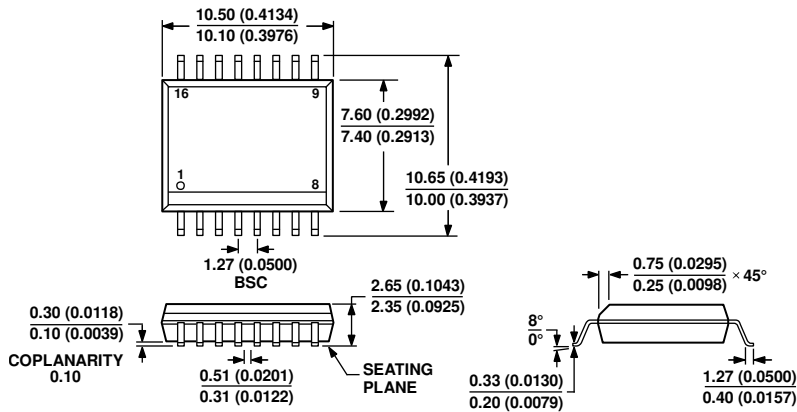

COMPLIANT TO JEDEC STANDARDS MS-013-AA
 CONTROLLING DIMENSIONS ARE IN MILLIMETERS; INCH DIMENSIONS (IN PARENTHESES) ARE ROUNDED-OFF MILLIMETER EQUIVALENTS FOR REFERENCE ONLY AND ARE NOT APPROPRIATE FOR USE IN DESIGN.

Figure 43. 16-Lead Standard Small Outline Package [SOIC_W] Wide Body (RW-16)

Dimensions shown in millimeters and (inches)

070606-A

032707-B

ORDERING GUIDE

Model	Temperature Range	Package Description	Package Option
OP497FP	-40°C to +85°C	14-Lead Plastic Dual In-Line Package [PDIP]	N-14
OP497FPZ ¹	-40°C to +85°C	14-Lead Plastic Dual In-Line Package [PDIP]	N-14
OP497GP	-40°C to +85°C	14-Lead Plastic Dual In-Line Package [PDIP]	N-14
OP497GPZ ¹	-40°C to +85°C	14-Lead Plastic Dual In-Line Package [PDIP]	N-14
OP497FS	-40°C to +85°C	16-Lead Standard Small Outline Package [SOIC_W]	RW-16
OP497FS-REEL	-40°C to +85°C	16-Lead Standard Small Outline Package [SOIC_W]	RW-16
OP497FSZ ¹	-40°C to +85°C	16-Lead Standard Small Outline Package [SOIC_W]	RW-16
OP497FSZ-REEL	-40°C to +85°C	16-Lead Standard Small Outline Package [SOIC_W]	RW-16
OP497GS	-40°C to +85°C	16-Lead Standard Small Outline Package [SOIC_W]	RW-16
OP497GS-REEL	-40°C to +85°C	16-Lead Standard Small Outline Package [SOIC_W]	RW-16
OP497GSZ ¹	-40°C to +85°C	16-Lead Standard Small Outline Package [SOIC_W]	RW-16
OP497GSZ-REEL ¹	-40°C to +85°C	16-Lead Standard Small Outline Package [SOIC_W]	RW-16

¹ Z = RoHS Compliant Part.

OP497

NOTES