



Chipsmall Limited consists of a professional team with an average of over 10 year of expertise in the distribution of electronic components. Based in Hongkong, we have already established firm and mutual-benefit business relationships with customers from,Europe,America and south Asia,supplying obsolete and hard-to-find components to meet their specific needs.

With the principle of “Quality Parts,Customers Priority,Honest Operation,and Considerate Service”,our business mainly focus on the distribution of electronic components. Line cards we deal with include Microchip,ALPS,ROHM,Xilinx,Pulse,ON,Everlight and Freescale. Main products comprise IC,Modules,Potentiometer,IC Socket,Relay,Connector.Our parts cover such applications as commercial,industrial, and automotives areas.

We are looking forward to setting up business relationship with you and hope to provide you with the best service and solution. Let us make a better world for our industry!



Contact us

Tel: +86-755-8981 8866 Fax: +86-755-8427 6832

Email & Skype: info@chipsmall.com Web: www.chipsmall.com

Address: A1208, Overseas Decoration Building, #122 Zhenhua RD., Futian, Shenzhen, China



NPN Silicon Phototransistor

OP600 Series



Features:

- Narrow receiving angle
- Variety of sensitivity ranges
- Enhanced temperature range
- PC Board Mounting
- Mechanically and spectrally matched to OP123 and OP223 LEDs
- TX and TXV processing available (see Hi-Rel section)



Description:

Each device in this series is a NPN silicon phototransistor in a hermetically sealed pill package. The narrow receiving angle provides excellent on-axis coupling

The **OP600** series devices are 100% production tested using infrared light for close correlation with OPTEK GaAs and GaAlAs emitters. Components in the OP600 series are mechanically and spectrally matched to the OP123 and OP233 series

TX and TXV components are available. For more information, please contact your local representative or OPTEK.

Please refer to Application Bulletins 208 and 210 for additional information and reliability (degradation) data, and to Application Bulletin 202 for pill-type soldering to PC Board.

Applications:

- Non-contact reflective object sensor
- Assembly line automation
- Machine automation
- Machine safety
- End of travel sensor
- Door sensor

Pin #	Sensor
1	Collector/Cathode
2	Emitter/Anode

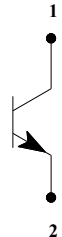

Ordering Information				
Part Number	Sensor	Light Current $I_{C(ON)}$ (mA) Min / Max	Input Power E_E (mW/cm ²)	Viewing Angle
OP600A	Transistor	1.20 / NA	2.5	35°
OP600B		0.60 / 1.80		
OP600C		0.30 / NA		
OP643SL		4.00 / 8.00	20.0	
OP644SL		7.00 / 22.00		

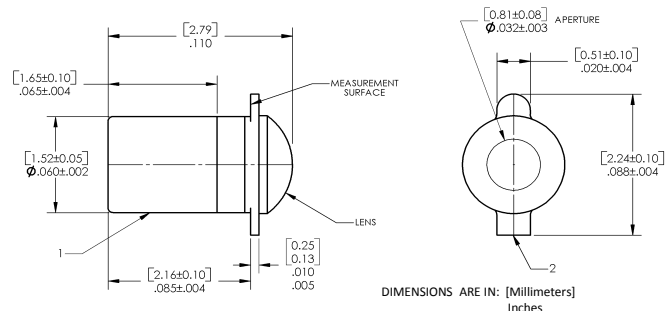

DO NOT LOOK DIRECTLY AT LED WITH UNSHIELDED EYES OR DAMAGE TO RETINA MAY

General Note

TT Electronics reserves the right to make changes in product specification without notice or liability. All information is subject to TT Electronics' own data and is considered accurate at time of going to print.

TT Electronics | Optek Technology, Inc.
1645 Wallace Drive, Ste. 130, Carrollton, TX USA 75006 | Ph: +1 972 323 2200
www.ttelectronics.com | sensors@ttelectronics.com

Absolute Maximum Ratings (TA = 25°C unless otherwise noted)

Collector-Emitter Voltage	25 V
Emitter-Collector Voltage	5 V
Storage Temperature Range	-65° C to +150° C
Operating Temperature Range	-65° C to +125° C
Soldering Temperature (5 seconds with soldering iron)	260° C ⁽¹⁾⁽²⁾
Power Dissipation	50 mW ⁽³⁾
Continuous Collector Current	50 mA

Electrical Characteristics (TA = 25° C unless otherwise noted)

SYMBOL	PARAMETER	MIN	TYP	MAX	UNITS	TEST CONDITIONS
I _{C(ON)} ⁽⁴⁾	On-State Collector Current		-			V _{CE} = 5 V, E _E = 2.5 mW/cm ²⁽⁵⁾
	OP600A	1.2	-	1.8	mA	V _{CE} = 5 V, E _E = 20 mW/cm ²⁽⁵⁾
	OP600B	0.6	-	1.8		
	OP600C	0.3	-	1.8		
	OP643SL	4.0	-	8.0		
	OP644SL	7.0	-	22.0		
-	-	-	-	-		
I _{CEO}	Collector-Dark Current	-	-	-	nA	V _{CE} = 10 V, E _E = 0
V _{(BR)CEO}	Collector-Emitter Breakdown Voltage	25	-	-	V	I _C = 100 μA
V _{(BR)ECO}	Emitter-Collector Breakdown Voltage	5	-	-	V	I _E = 100 μA
V _{CE(SAT)} ⁽⁴⁾	Collector-Emitter			0.4	V	I _C = 0.15 mA, E _E = 2.5 mW/cm ²⁽⁵⁾ I _C = 0.4 mA, E _E = 20 mW/cm ²⁽⁵⁾
	OP600 (A, B, C) ⁽²⁾⁽⁷⁾ OP643-644 (SL) ⁽²⁾⁽⁷⁾	-	-	-		
t _r	Rise Time	-	15	-	μs	V _{CC} = 5 V, I _C = 0.80 mA, R _L = 1 kΩ, See Test Circuit
t _f	Fall Time	-	15	-	μs	V _{CC} = 5 V, I _C = 0.80 mA, R _L = 1 kΩ, See Test Circuit

Notes:

- (1) Refer to Application Bulletin 202, which discusses proper techniques for soldering pill-type devices to PCBs.
- (2) No clean or low solids. RMA flux is recommended. Duration can be extended to 10 seconds maximum when flow soldering.
- (3) Derate linearly 0.5 mW/° C above 25° C.
- (4) Junction temperature maintained at 25° C.
- (5) For OP600A, OP600B and OP600C, light source is a GaAlAs LED, peak wavelength = 890 nm, that provides irradiance of 2.5 mW/cm². The source irradiance is not necessarily uniform over the entire lens area of the unit being tested.
- (6) For OP643SL and OP644SL, light source is an unfiltered tungsten bulb operating at CT = 2870 K or equivalent infrared source.

General Note

TT Electronics reserves the right to make changes in product specification without notice or liability. All information is subject to TT Electronics' own data and is considered accurate at time of going to print.

TT Electronics | Optek Technology, Inc.
1645 Wallace Drive, Ste. 130, Carrollton, TX USA 75006 | Ph: +1 972 323 2200
www.ttelectronics.com | sensors@ttelectronics.com