



Chipsmall Limited consists of a professional team with an average of over 10 year of expertise in the distribution of electronic components. Based in Hongkong, we have already established firm and mutual-benefit business relationships with customers from,Europe,America and south Asia,supplying obsolete and hard-to-find components to meet their specific needs.

With the principle of "Quality Parts,Customers Priority,Honest Operation,and Considerate Service",our business mainly focus on the distribution of electronic components. Line cards we deal with include Microchip,ALPS,ROHM,Xilinx,Pulse,ON,Everlight and Freescale. Main products comprise IC,Modules,Potentiometer,IC Socket,Relay,Connector.Our parts cover such applications as commercial,industrial, and automotives areas.

We are looking forward to setting up business relationship with you and hope to provide you with the best service and solution. Let us make a better world for our industry!



Contact us

Tel: +86-755-8981 8866 Fax: +86-755-8427 6832

Email & Skype: info@chipsmall.com Web: www.chipsmall.com

Address: A1208, Overseas Decoration Building, #122 Zhenhua RD., Futian, Shenzhen, China



Photologic® Reflective Object Sensor Types OPB715, OPB716, OPB717, OPB718



Features

- Focused for maximum sensitivity
- 0.5" (12.7mm) sensing distance
- Panel mount
- Choice of output configurations
- 18" minimum wire length

Description

The OPB715 series reflective assembly consists of a GaAlAs LED and a Photologic® sensor enclosed in an IR transmissive housing. The sensor is characterized to detect paper at 0.5" (12.7 mm). However, the OPB715 has a wide operating distance range and is capable of detecting reflective objects at longer distances. Even low reflectance materials can be detected at shorter distances.

The sensor's panel-mount plastic housing shields stray light and is terminated with 18" wire leads. The output can be specified as either TTL totem-pole or TLL open-collector in buffer or inverter polarity. The LED is current limited internally for design convenience.

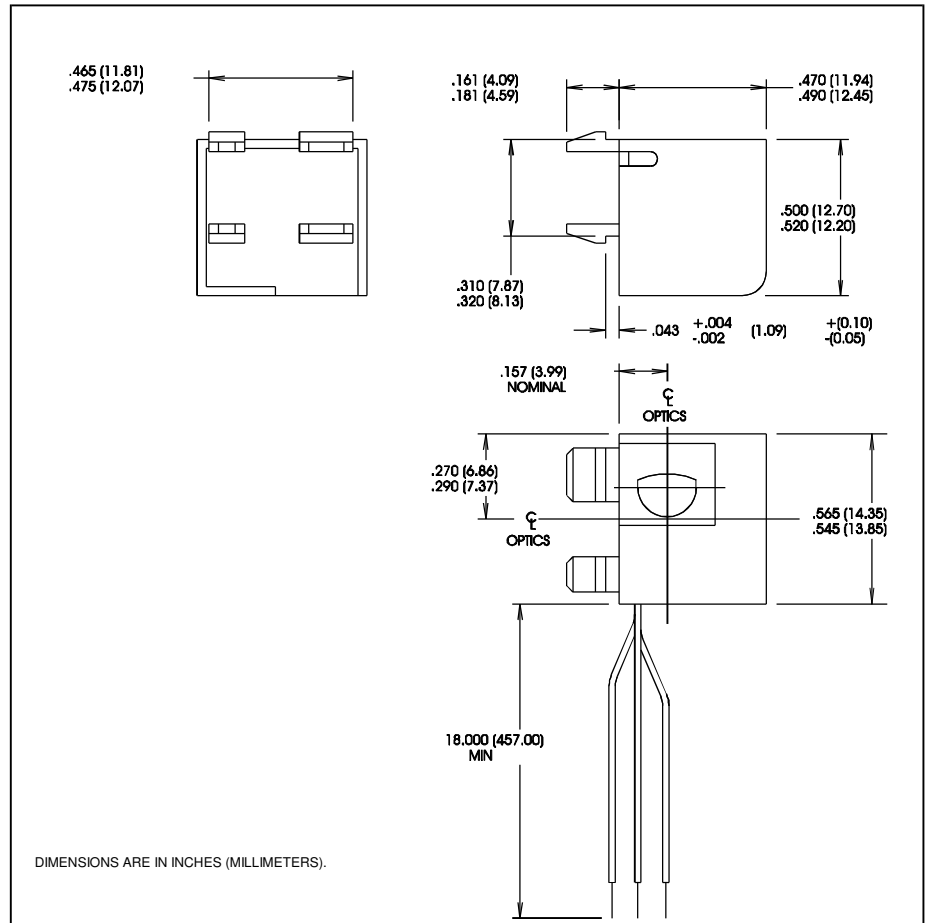

Absolute Maximum Ratings (TA = 25° C unless otherwise noted)

Supply Voltage, VCC (not to exceed 2 sec.)	10 V
Storage Temperature Range	-40° C to +85° C
Operating Temperature Range	-40° C to +85° C
Power Dissipation	300 mW ⁽¹⁾
Output Voltage (Open-Collector only)	35 V

Notes:

- (1) Derate linearly at 5.00 mW/°C above 25° C.
- (2) Terminating wire is 7 strand, 26 AWG, UL 1429.
- (3) Tested at d = 0.5" (12.7 mm) from a 90% diffuse, white test surface.
Reference: Eastman Kodak Catalog # 1257795.
- (4) No reflective surface.



For RoHS compliant devices add "Z" to the end of the part number: OPB715Z

Types OPB715, OPB716, OPB717, OPB718

Electrical Characteristics ($T_A = -40^\circ\text{C}$ to $+85^\circ\text{C}$ unless otherwise specified)

SYMBOL	PARAMETER	MIN	TYP	MAX	UNITS	TEST CONDITIONS
V_{CC}	Operating D.C. Supply Voltage	4.75		5.25	V	
I_{CCL}	Low Level Supply Current: OPB715: Buffered Totem-Pole Output OPB716: Buffered Open-Collector Output			50	mA	$V_{CC} = 5.25\text{ V}$, Output Open
	OPB717: Inverted Totem-Pole Output OPB718: Inverted Open-Collector Output			50	mA	$V_{CC} = 5.25\text{ V}$, Output Open
I_{CCH}	High Level Supply Current: OPB715: Buffered Totem-Pole Output OPB716: Buffered Open-Collector Output			50	mA	$V_{CC} = 5.25\text{ V}$, Output Open
	OPB717: Inverted Totem-Pole Output OPB718: Inverted Open-Collector Output			50	mA	$V_{CC} = 5.25\text{ V}$, Output Open
I_{OH}	High Level Output Current: OPB716: Buffered Open-Collector Output OPB718: Inverted Open-Collector Output			100	μA	$V_{CC} = 5\text{ V}$, $V_{OH} = 5\text{ V}^{(3)}$
				100	μA	$V_{CC} = 5\text{ V}$, $V_{OH} = 5\text{ V}^{(4)}$
I_{OS}	Short Circuit Output Current: OPB715: Buffered Totem-Pole Output OPB717: Inverted Totem-Pole Output					
V_{OL}	Low Level Output Voltage: OPB715: Buffered Totem-Pole Output OPB716: Buffered Open-Collector Output			0.4	V	$V_{CC} = 5\text{ V}$, $I_{OL} = 12.8\text{ mA}^{(4)}$
	OPB717: Inverted Totem-Pole Output OPB718: Inverted Open-Collector Output			0.4	V	$V_{CC} = 5\text{ V}$, $I_{OL} = 12.8\text{ mA}^{(3)}$

OPB715: Totem-Pole Buffer Output

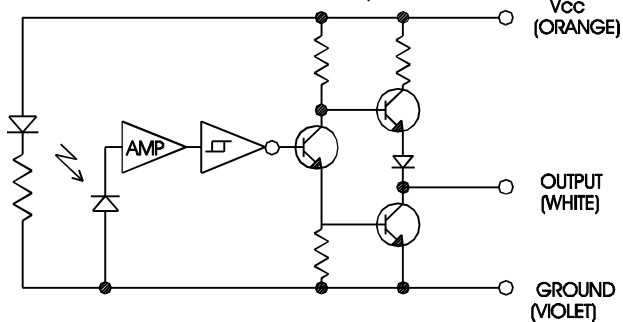

OPB716: Open-Collector Buffer Output

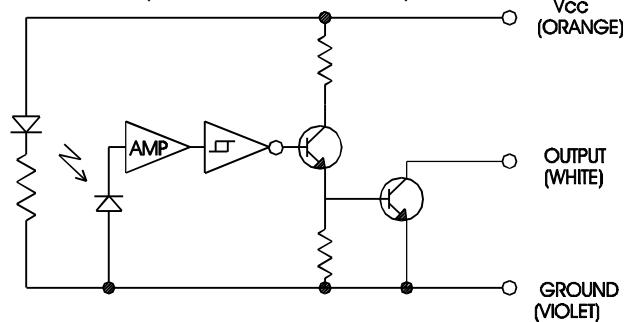

OPB717: Totem-Pole Inverter Output

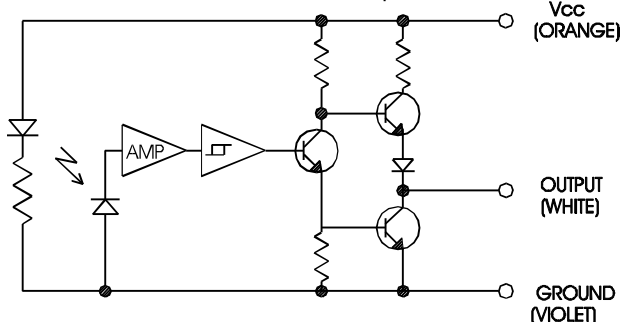

OPB718: Open-Collector Inverter Output

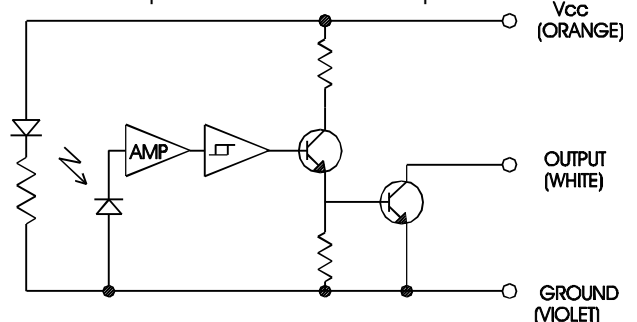

Optek reserves the right to make changes at any time in order to improve design and to supply the best product possible.

Optek Technology, Inc. 1215 W. Crosby Road Carrollton, Texas 75006 (972)323-2200 Fax (972)323-2396