



Chipsmall Limited consists of a professional team with an average of over 10 year of expertise in the distribution of electronic components. Based in Hongkong, we have already established firm and mutual-benefit business relationships with customers from,Europe,America and south Asia,supplying obsolete and hard-to-find components to meet their specific needs.

With the principle of “Quality Parts,Customers Priority,Honest Operation,and Considerate Service”,our business mainly focus on the distribution of electronic components. Line cards we deal with include Microchip,ALPS,ROHM,Xilinx,Pulse,ON,Everlight and Freescale. Main products comprise IC,Modules,Potentiometer,IC Socket,Relay,Connector.Our parts cover such applications as commercial,industrial, and automotives areas.

We are looking forward to setting up business relationship with you and hope to provide you with the best service and solution. Let us make a better world for our industry!



Contact us

Tel: +86-755-8981 8866 Fax: +86-755-8427 6832

Email & Skype: info@chipsmall.com Web: www.chipsmall.com

Address: A1208, Overseas Decoration Building, #122 Zhenhua RD., Futian, Shenzhen, China



Photologic® Optically Coupled Isolator

OPI127-032

Features:

- Four output options
- 15 kV input-to-output isolation voltage
- Direct TTL/STTL interface
- High noise immunity
- Data rates to 250 KBit/s
- Hermetically sealed
- UL File No. E 58730*

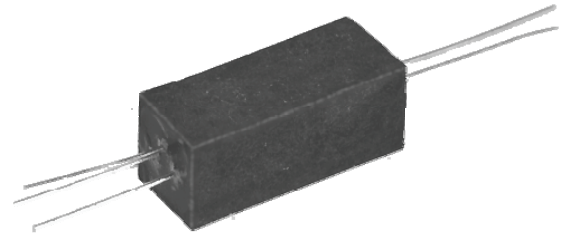

Description:

The **OPI127-032** consists of an optically coupled isolator with a gallium arsenide infrared emitting diode coupled to a monolithic integrated circuit. This circuit incorporates a photodiode, a linear amplifier and a Schmitt trigger on a single silicon chip. For maximum long-term stability, both the diode and the Photologic® sensor are hermetically sealed in separate packages and then mounted in a high dielectric plastic housing.

This device features TTL/LSTTL compatible logic level output that can drive up to 8 TTL loads directly without additional circuitry. Also featured are medium-speed data rates to 250 KBit/s, with typical rise and fall times of 70 nanoseconds. *UL recognition is for 15KV_{DC} to 100° C.

For more information, contact your local representative or OPTEK.

Applications:

- High voltage isolation between input and output
- Electrical isolation in dirty environments
- Industrial equipment
- Medical equipment
- Office equipment

Pin #	LED	Pin #	Photologic®
1	Anode	5	Output
2	Cathode	4	Vcc
		3	Ground

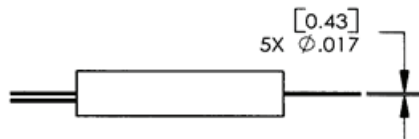

NOTES:

1. DIMENSIONS ARE IN INCHES [MM].
2. DIMENSIONS WITH * ARE CONTROLLED AT HOUSING EGRESSION.

Ordering Information								
Part Number	LED Peak Wavelength	Sensor Photologic®	Isolation Voltage (,000)	t _{PLH} / t _{PHL} Typ (μs)	I _F (mA) Typ / Max	V _{CE} (Volts) Max	Lead Length / Spacing	*Length
OPI127-032	890nm	Inverted Totem Pole	15	5 / 5	7.5 / 25	35.0	0.40" / 0.75"	1.26" [32mm]

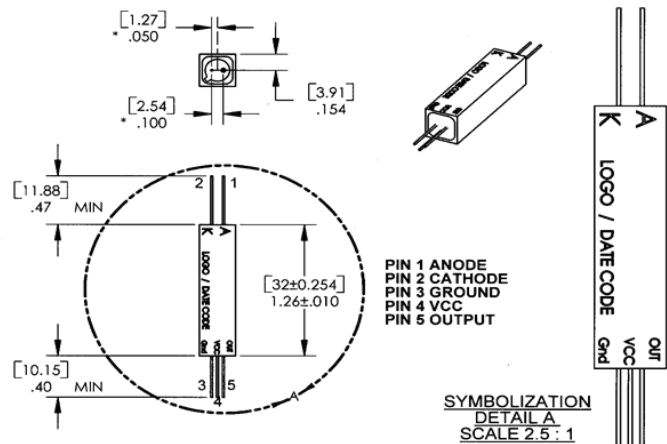

RoHS

General Note

TT Electronics reserves the right to make changes in product specification without notice or liability. All information is subject to TT Electronics' own data and is considered accurate at time of going to print.



1645 Wallace Drive, Carrollton, TX 75006 | Ph: +1 972 323 2200
 www.optekinc.com | www.ttelectronics.com

Photologic® Optically Coupled Isolator

OPI127-032

OPI127-032 - Inverted Totem Pole Output

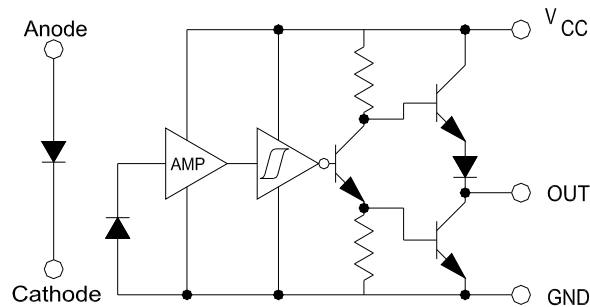

Absolute Maximum Ratings ($T_A = 25^\circ\text{C}$ unless otherwise noted)

Storage Temperature	-55° C to +100° C
Operating Temperature	-55° C to +100° C
Supply Voltage, V_{CC} (not to exceed 3 seconds)	+10 V
Input-to-Output Isolation Voltage ⁽¹⁾⁽²⁾	± 15 kVDC
Lead Soldering Temperature (1/16" (1.6 mm) from case for 5 seconds with soldering iron) ⁽³⁾	260° C
Input Diode	
Forward DC Current	25 mA
Reverse DC Voltage	2 V
Power Dissipation ⁽⁴⁾	200 mW
Output Photosensor	
Output Photologic® Power Dissipation ⁽⁵⁾	120 mW
Duration of Output Short to VCC or Ground	1.00 second
Voltage at Output Lead	35 V

Notes:

- (1) Measured with input and output leads shorted.
- (2) UL recognition is for 3500 Vrms at 60Hz.
- (3) RMA flux is recommended. Duration can be extended to 10 seconds maximum when flow soldering.
- (4) Derate linearly 1.33 mW/° C above 25° C.
- (5) Derate linearly 3.40 mW/° C above 90° C.

General Note

TT Electronics reserves the right to make changes in product specification without notice or liability. All information is subject to TT Electronics' own data and is considered accurate at time of going to print.

Photologic® Optically Coupled Isolator

OPI127-032

Electrical Characteristics ($T_A = -40^\circ\text{C}$ to $+85^\circ\text{C}$ unless otherwise noted)

SYMBOL	PARAMETER	MIN	TYP	MAX	UNITS	TEST CONDITIONS
Diode Input (See OP130 and OP230 for additional information - for reference only)						
V_F	Forward Voltage	-	-	1.5	V	$I_F = 10\text{ mA}$, $T_A = 25^\circ\text{C}$
I_R	Reverse Current	-	-	100	μA	$V_R = 2\text{ V}$, $T_A = 25^\circ\text{C}$
$I_F(+)$	LED Positive-Going threshold Current	-	-	7.5	mA	$V_{CC} = 5\text{ V}$, $T_A = 25^\circ\text{C}$
$I_F(+)/I_F(-)$	Hysteresis Ratio	-	2.0	-	-	-
Photologic® Output (See OP800 and OP801 for additional information - for reference only)						
V_{CC}	Operating Supply Voltage	4.5	-	5.5	V	-
I_{CC}	Supply Current	-	-	20	mA	$V_{CC} = 5.5\text{ V}$, $I_F = 0$ or 7.5 mA
V_{OL}	Low Level Output Voltage	-	-	0.40	V	$V_{CC} = 4.5\text{ V}$, $I_{OL} = 13\text{ mA}$, $I_F = 0\text{ mA}$ $V_{CC} = 4.5\text{ V}$, $I_{OL} = 13\text{ mA}$, $I_F = 7.5\text{ mA}$
V_{OH}	High Level Output Voltage	2.4	-	-	V	$V_{CC} = 4.5\text{ V}$, $I_{OH} = -800\ \mu\text{A}$, $I_F = 7.5\text{ mA}$ $V_{CC} = 4.5\text{ V}$, $I_{OH} = -800\ \mu\text{A}$, $I_F = 0\text{ mA}$
I_{OS}	Short Circuit Output Current	-20	-	-120	mA	$V_{CC} = 5.5\text{ V}$, $I_F = 7.5\text{ mA}$, Output = GND $V_{CC} = 5.5\text{ V}$, $I_F = 0\text{ mA}$, Output = GND
I_{OH}	High Level Output Current	-	-	100	μA	$V_{CC} = 4.5\text{ V}$, $V_{OH} = 30\text{ V}$, $I_F = 7.5\text{ mA}$ $V_{CC} = 4.5\text{ V}$, $V_{OH} = 30\text{ V}$, $I_F = 0\text{ mA}$
t_r, t_f	Output Rise Time, Output Fall Time	-	100	-	ns	$V_{CC} = 5\text{ V}$, $T_A = 25^\circ\text{C}$, $I_F = 0$ or 10 mA , $f = 10\text{ kHz}$, D.C. = 50%, $R_L = 8\text{ TTL loads}$
t_{PLH}, t_{PHL}	Propagation Delay, Low-High, High-Low	-	5	-	μs	$V_{CC} = 5\text{ V}$, $T_A = 25^\circ\text{C}$, $I_F = 0$ or 10 mA , $f = 10\text{ kHz}$, D.C. = 50%, $R_L = 8\text{ TTL loads}$

Notes:

- (1) Measured with input and output leads shorted in air with a maximum relative humidity of 50%. If suitably encapsulated or oil-immersed, the isolation voltage is increased to 25 kV minimum.

General Note

TT Electronics reserves the right to make changes in product specification without notice or liability. All information is subject to TT Electronics' own data and is considered accurate at time of going to print.