



Chipsmall Limited consists of a professional team with an average of over 10 year of expertise in the distribution of electronic components. Based in Hongkong, we have already established firm and mutual-benefit business relationships with customers from,Europe,America and south Asia,supplying obsolete and hard-to-find components to meet their specific needs.

With the principle of “Quality Parts,Customers Priority,Honest Operation,and Considerate Service”,our business mainly focus on the distribution of electronic components. Line cards we deal with include Microchip,ALPS,ROHM,Xilinx,Pulse,ON,Everlight and Freescale. Main products comprise IC,Modules,Potentiometer,IC Socket,Relay,Connector.Our parts cover such applications as commercial,industrial, and automotives areas.

We are looking forward to setting up business relationship with you and hope to provide you with the best service and solution. Let us make a better world for our industry!



Contact us

Tel: +86-755-8981 8866 Fax: +86-755-8427 6832

Email & Skype: info@chipsmall.com Web: www.chipsmall.com

Address: A1208, Overseas Decoration Building, #122 Zhenhua RD., Futian, Shenzhen, China



SIGN	DATE	DESCRIPTION	APPROVER
△	2009.01.21	AWG changed from 20-22 to 18-22AWG(Str/sol)	Lee
△	2009.01.21	CUL approval added	Lee

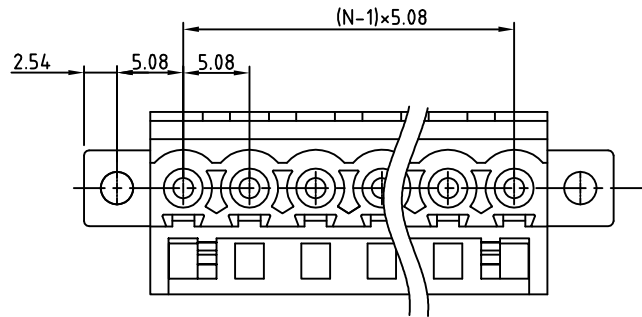

POLE	TOL
2 pole~5 pole	±0.05
6 pole~8 pole	±0.10
9 pole~12 pole	±0.20

MATERIAL

- Terminal Body(Contact pin): PhBz
- With flange screw: steel M2.5 plated zinc
- Insulator (housing): Thermoplastic(UL94V-0)

ELECTRICAL

- Voltage rating: 300V
- Current rating: 8A
- △ ● Wire range:
 - Solid wire(AWG): 18-22
 - Stranded wire(AWG): 18-22
- Wire strip length:
- Withstanding Voltage: 1.6KV
- Operating temperature: -30°C to +105°C
- △ ● Safety approval: US

RoHS Compliant

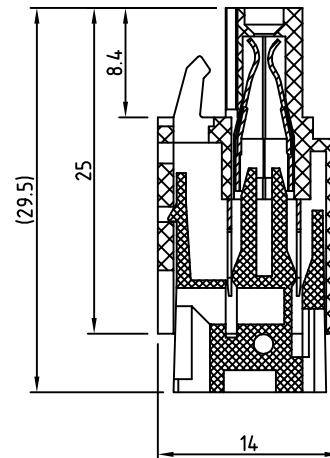
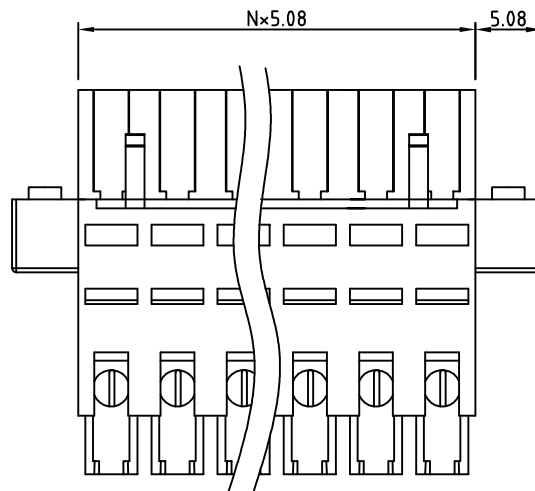

PART NUMBER:

OSTHPXX5052

No. of Poles
02: 2 Poles
:
:
12: 12 Poles

COLOR
0: Black
5: Green (Standard)
6: Blue
8: Grey

N=Number of poles

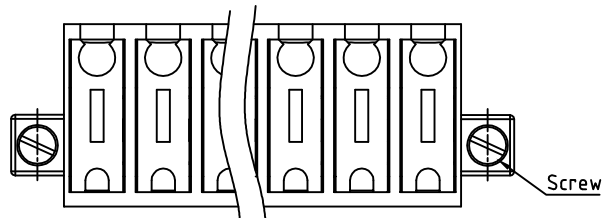

THESE DRAWINGS AND SPECIFICATIONS ARE THE PROPERTY OF ON-SHORE TECHNOLOGY, INC. AND SHALL NOT BE REPRODUCED, COPIED OR USED IN ANY MANNER WITHOUT THE PRIOR WRITTEN CONSENT OF ON-SHORE TECHNOLOGY, INC.



ON-SHORE TECHNOLOGY, INC.

TITLE		OSTHP 5.08mm Series with flange			
PART NO.	OSTHPXX5052	DWG NO.	OSTHPXX5052.DWG		
APPROVED	CHECKED	DESIGNED	DRAWN	CUST NO.	Tolerance
Shi Jun 2006.11.13	Marvin 2006.11.13	Marvin 2006.11.13	Marvin 2006.11.13		X. ±0.50
					X.X ±0.30
					X.XX ±0.10
					X° ±1°
				SHEET: 01/01	REV: D