



Chipsmall Limited consists of a professional team with an average of over 10 year of expertise in the distribution of electronic components. Based in Hongkong, we have already established firm and mutual-benefit business relationships with customers from,Europe,America and south Asia,supplying obsolete and hard-to-find components to meet their specific needs.

With the principle of "Quality Parts,Customers Priority,Honest Operation,and Considerate Service",our business mainly focus on the distribution of electronic components. Line cards we deal with include Microchip,ALPS,ROHM,Xilinx,Pulse,ON,Everlight and Freescale. Main products comprise IC,Modules,Potentiometer,IC Socket,Relay,Connector.Our parts cover such applications as commercial,industrial, and automotives areas.

We are looking forward to setting up business relationship with you and hope to provide you with the best service and solution. Let us make a better world for our industry!



Contact us

Tel: +86-755-8981 8866 Fax: +86-755-8427 6832

Email & Skype: info@chipsmall.com Web: www.chipsmall.com

Address: A1208, Overseas Decoration Building, #122 Zhenhua RD., Futian, Shenzhen, China



OTFI-0290

XLM High Output LED Fiber Optic Light Module



OTFI-0290

Overview

Excelitas' XLM LED Fiber Optic Illuminator series combines the latest technology in solid state lighting with precision optics and advanced thermal management to deliver a revolution in high-brightness fiber optic illumination. The XLM LED Light Module is designed for integration into endoscope light sources, surgical microscopes, headlights and other applications that require bright, uniform illumination.

The high-performance LED Fiber Optic Light Module provides many advantages for the medical environment such as remarkable uniformity, virtually no ultraviolet or infrared emissions, maintenance-free, long-life operation, and a variable speed fan. Users of xenon, metal-halide and halogen lamps now have an alternative light source with all of these features.

In order to minimize an OEM's design time and reduce time-to-market, the fiber optic module includes both metric and imperial mechanical mounting fasteners. A flange-mount shaft with pilot holes located on a 27 mm diameter circle enables device manufacturers to integrate their own fiber coupling.

The XLM LED Fiber Optic Illuminator Series incorporates patent-pending LED technology, precision optics, an integrated state-of-the art thermal management system, electromagnetic interference shielding, and easy access screw terminals for electrical connections.

Excelitas offers OEMs a variety of component-level light modules to choose from and has a fiber optic illumination solution to meet every need.

www.excelitas.com

OTFI-0290-13 Rev B page 1 of 4

Key Features

- Bright - 20% more light output than our standard OTFI-0250
- Safe - emits virtually no ultraviolet or infrared radiation
- Easy coupling – flange-mounted optical alignment features for fiber input port
- Low electrical noise – EMI-shielded
- Energy-efficient - consumes less energy than Xenon
- On board temperature sensor for thermal monitoring
- Variable speed fan
- Compatible with 1 mm – 6 mm diameter fibers
- RoHS-compliant

Applications

- Endoscopy Light Sources
- Surgical Microscopy
- Medical Headlights

OTFI-0290

XLM High Output LED Fiber Optic Light Module

Product Specifications

Parameter	Symbol	Min.	Typ.	Max	Unit	Remarks / Conditions
Optical Characteristics						
Luminous Flux			2400		Lumens	
Color Temperature	CCT	5500	6300	7800	Kelvin	
Angle of light exit	FWHM		76		degrees	At 50% intensity points
Fiber Compatibility	Φ	1	5	6	mm	
Electrical Characteristics						
Input Voltage	VDC			5.4	Volts	Voltage for reference
Input Current	A			18		
Environmental Characteristics						
Cooling method	DC fan	7		12	Volts	Fan is rated for 70K hours
Operating Temperature	T_o	0°... +40°	Humidity: 85% or less		°C	
Storage Temperature	T_s	-20°... +65°	Humidity: 85% or less		°C	
Dimensions						
Physical dimensions	99 mm x 110 mm x 177 mm (H x W x D) 3.9" x 4.3" x 6.9" (H x W x D)					
Weight	916 grams; 32 ounces					
Safety						
Safety standards	Compliant with IEC/EN 60601-1 2 nd and 3 rd editions (CE Mark); RoHS per Eur. Directive 2011/65/EU					

Excelitas' XLM Fiber Optic Light Module, OTFI-0290, is a component-level module supplied to OEM medical device manufacturers for integration into the device manufacturer's endoscope, surgical microscope or medical headlight system. The XLM includes: LEDs, optics, heat sink with fan, temperature sensor, and electrical terminal block. It is enclosed in a sheet metal enclosure with fan guards.

The user shall provide the driver control electronics, power supply, system enclosure, switches and mechanical interface for the fiber light guide.

Custom solutions are available. Please inquire with Excelitas Technologies.

OTFI-0290

XLM High Output LED Fiber Optic Light Module

Physical Configuration

OTFI-0290 Front View

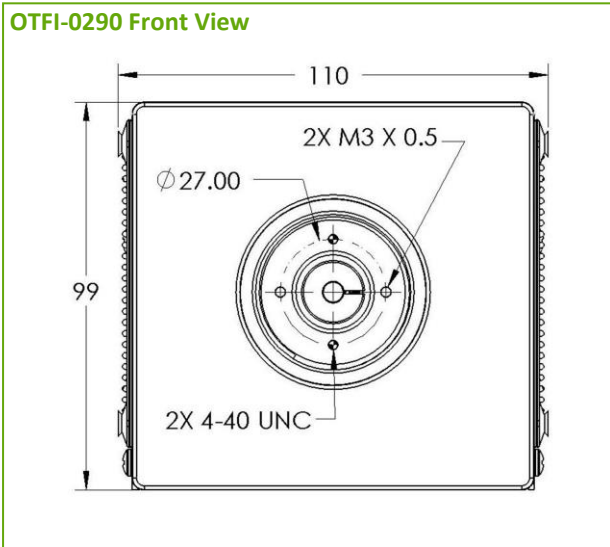

OTFI-0290 Side View

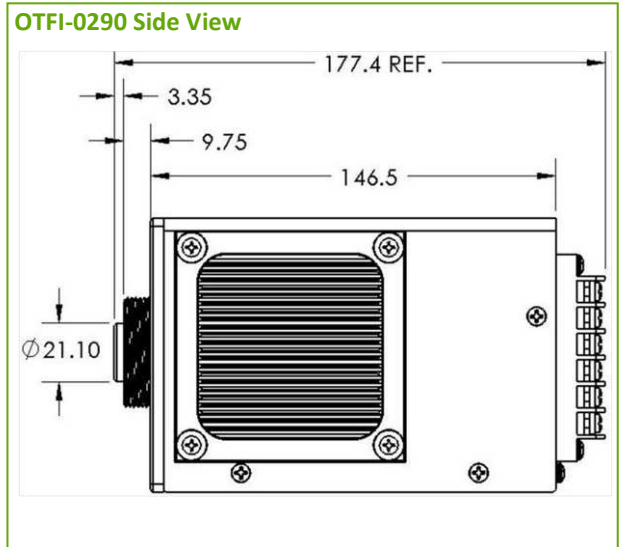

OTFI-0280 Bottom View

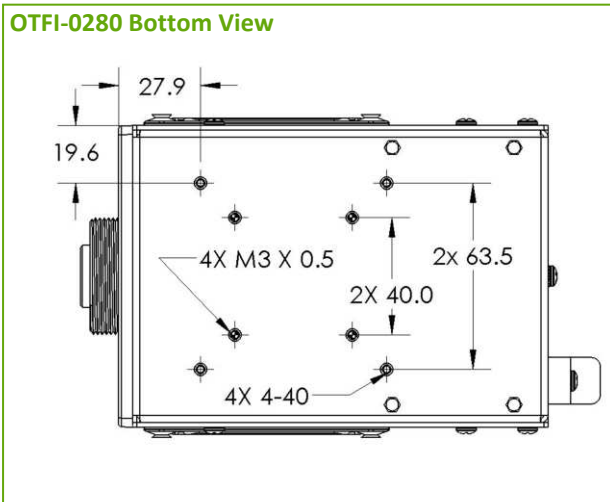

OTFI-0290 Rear View

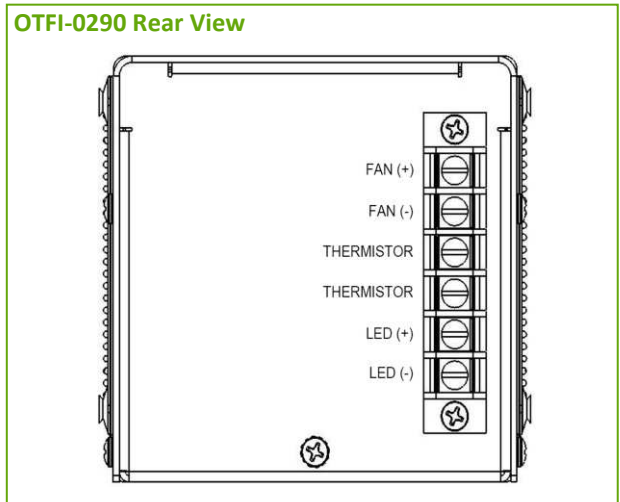

* All dimensions shown in mm

OTFI-0290

XLM High Output LED Fiber Optic Light Module

Spectral Profile

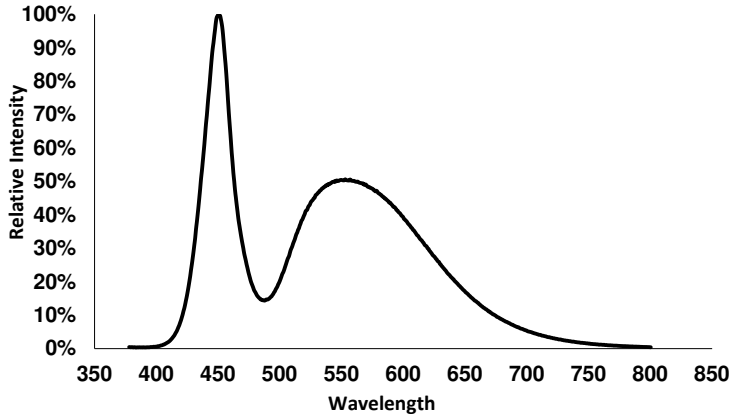

About Excelitas Technologies

Excelitas Technologies is a global technology leader focused on delivering innovative, customized solutions to meet the lighting, detection and other high-performance technology needs of OEM customers.

From medical lighting to analytical instrumentation, clinical diagnostics, industrial, safety and security, and aerospace and defense applications, Excelitas Technologies is committed to enabling our customers' success in their specialty end-markets. Excelitas Technologies has approximately 5,000 employees in North America, Europe and Asia, serving customers across the world.

Spatial Profile

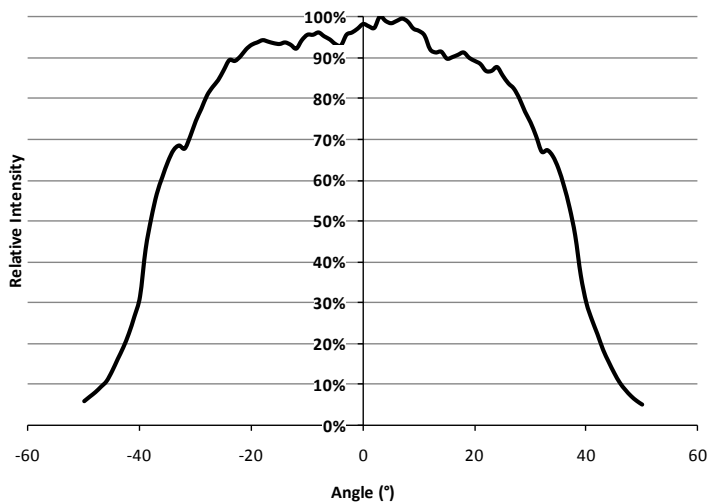

Limited warranty for 24 months from date of purchase.
US and International patents pending.
Product improvements may result in specification or feature changes without notice.

Excelitas Technologies Corp.
160 E. Marquardt Drive
Wheeling, Illinois 60090
USA
Telephone: (+1)847.537.4277
Fax: (+1) 847.537.4785

**Excelitas Technologies
Elcos GmbH**
Luitpoldstrasse 6
Pfaffenhofen, 85276
Germany
Telephone: (+49)8441.8917.0
Fax: (+49) 8441.7191.0

Excelitas Technologies Shenzhen Co., Ltd.
Wearnes Technology Center
No.10 Kefa Road, Science & Industry Park,
Nanshan District,
Shenzhen, Guangdong, 518057
China
Telephone: (+86)2655 3861
Fax: (+86)755 2661 7311

EXCELITAS
TECHNOLOGIES

For a complete listing of our global offices, visit www.excelitas.com/ContactUs

© 2011 Excelitas Technologies Corp. All rights reserved. The Excelitas logo and design are registered trademarks of Excelitas Technologies Corp. All other trademarks not owned by Excelitas Technologies or its subsidiaries that are depicted herein are the property of their respective owners. Excelitas reserves the right to change this document at any time without notice and disclaims liability for editorial, pictorial or typographical errors.