



Chipsmall Limited consists of a professional team with an average of over 10 year of expertise in the distribution of electronic components. Based in Hongkong, we have already established firm and mutual-benefit business relationships with customers from,Europe,America and south Asia,supplying obsolete and hard-to-find components to meet their specific needs.

With the principle of “Quality Parts,Customers Priority,Honest Operation,and Considerate Service”,our business mainly focus on the distribution of electronic components. Line cards we deal with include Microchip,ALPS,ROHM,Xilinx,Pulse,ON,Everlight and Freescale. Main products comprise IC,Modules,Potentiometer,IC Socket,Relay,Connector.Our parts cover such applications as commercial,industrial, and automotives areas.

We are looking forward to setting up business relationship with you and hope to provide you with the best service and solution. Let us make a better world for our industry!



## Contact us

Tel: +86-755-8981 8866 Fax: +86-755-8427 6832

Email & Skype: info@chipsmall.com Web: www.chipsmall.com

Address: A1208, Overseas Decoration Building, #122 Zhenhua RD., Futian, Shenzhen, China



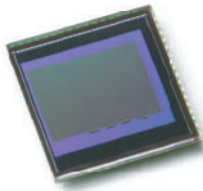

# OV8810 8 megapixel product brief



## 1/3-inch, 8 Megapixel CameraChip™ Sensor with OmniBSI™ Technology



available in  
a lead-free  
package

The OV8810 CameraChip sensors are the world's first 1/3.2-inch, 8 megapixel sensors using OmniVision's proprietary 1.4 micron OmniBSI backside illumination pixel architecture. This technology offers best-in-class low-light sensitivity and image quality in a very small footprint.

OmniBSI technology enables a reduction in sensor size and stack height, allowing the sensors to achieve a high chief ray angle (CRA), which in turn facilitates thinner camera module designs.

All required image processing functions for the OV8810, including exposure control, white balance and defective pixel canceling, are programmable through the serial camera control bus (SCCB) interface.

The OV8810 provides full-frame, sub-sampled, windowed 8-bit/10-bit/12-bit RGB data over a two-lane high speed MIPI interface or parallel SCCB interface. It can also be used to communicate to an external secondary camera (digital video port) while providing continued output through the MIPI interface. It has an image array capable of operating at up to 10 frames per second (fps) in full resolution with complete user control over image quality, formatting and output data transfer.

The OV8810 records 720p high definition (HD) video at 60 fps, 1080p HD at 30 fps, and 120 fps in QVGA resolution, ideal for slow motion preview.

Find out more at [www.ovt.com](http://www.ovt.com).

## Applications

- Mobile Phones
- DSC / DSV

## Product Features

- 1.4 micron OmniBSI technology
- low dark current
- flexible frame exposure control mode
- flexible strobe output to control flash
- programmable controls for gain, exposure, frame rate, image size, horizontal mirror, vertical flip, cropping, windowing and panning
- automatic image control functions:
  - automatic exposure (AEC)
  - automatic gain control (AGC)
  - automatic white balance (AWB)
  - automatic 50/60 Hz luminance detection
  - automatic black level calibration (ABLC)
- defect pixel correction and lens shading correction
- two-wire serial bus control
- MIPI serial output interface
- digital video port (DVP) parallel output interface
- support for second camera chipsharing MIPI interface
- support for black sun cancellation
- embedded one-time programmable (OTP) memory
- on-chip phase lock loop (PLL)
- frame exposure mode for still image (with mechanical shutter)
- built-in 1.5 V regulator for core

# OV8810

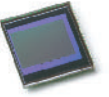

## Ordering Information

- OV88810-A67A (color, lead-free, 67-pin CSP3)
- OV88810-G04A (color, lead-free, reconstructed wafer)

## Product Specifications

- active array size: 3264 x 2448
- power supply:
  - core: 1.4 ~1.6 V (1.5 V typical)
  - analog: 2.6 ~3.1 V (2.8 V typical)
  - I/O: 1.7 ~3.1 V (1.8/2.8 V typical)
- power requirements:
  - active: 200 mA
  - standby: 800  $\mu$ A
  - power down: 150  $\mu$ A
- temperature range:
  - operating: -30°C to 70°C
  - stable image: 0°C to 50°C
- output formats: 8/10/12-bit RAW RGB data
- lens size: 1/3.2"
- lens chief ray angle: 27° no n-linear
- input clock frequency: 6 ~27 MHz
- maximum image transfer rate:
  - 8 Mpixel (3264x2448): 10 fps
  - 1080p: 30 fps
  - 720p: 60 fps
  - VGA: 60 fps
  - QVGA: 120 fps
- sensitivity: 650 mV/(lux-sec)
- pixel size: 1.4  $\mu$ m x 1.4  $\mu$ m
- dark current: 7.6 mV/sec at 60°C
- image area: 4614  $\mu$ m x 3506  $\mu$ m
- package/die dimensions:
  - CSP3: 6235  $\mu$ m x 6535  $\mu$ m
  - COB: 6250  $\mu$ m x 6550  $\mu$ m

## Functional Block Diagram

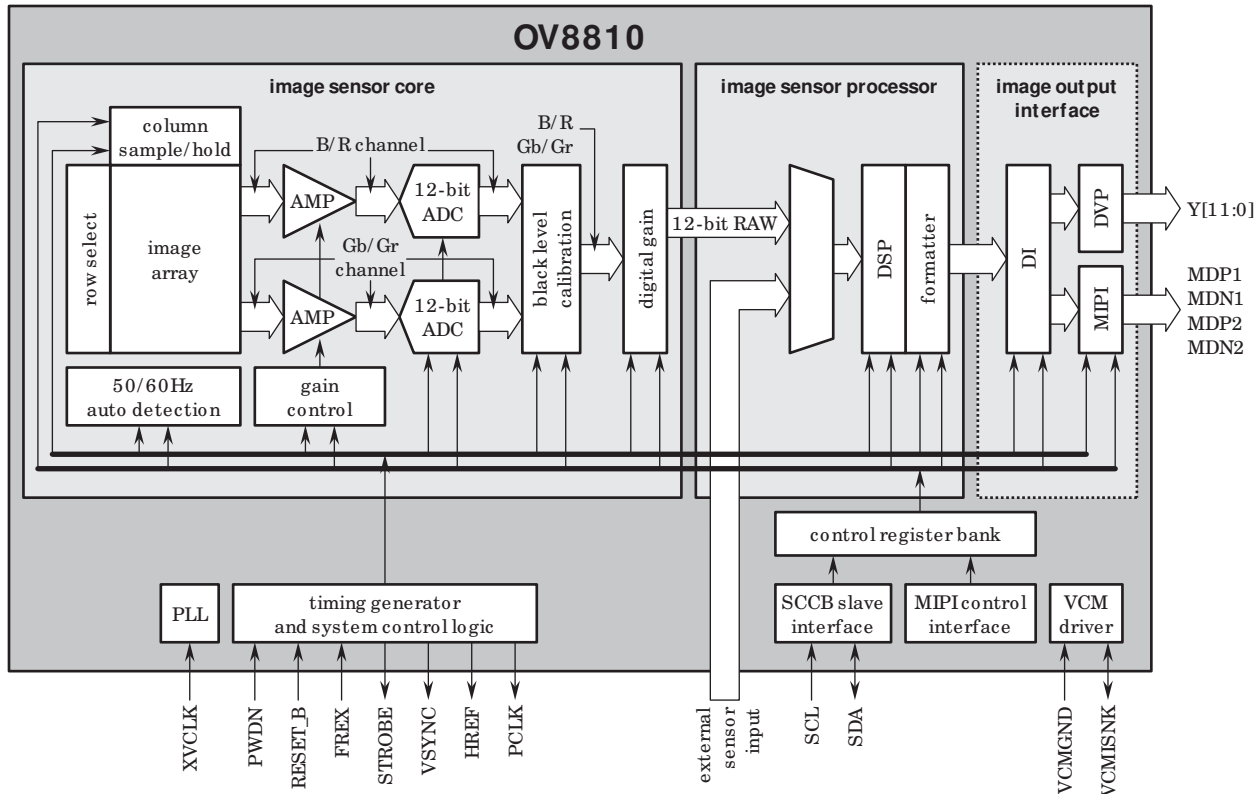

4275 Burton Drive  
Santa Clara, CA 95054  
USA

Tel: +1 408 567 3000  
Fax: +1 408 567 3001  
www.ovt.com

OmniVision reserves the right to make changes to their products or to discontinue any product or service without further notice. OmniVision and OmniPixel are registered trademarks of OmniVision Technologies, Inc. The OmniVision logo, CameraChip and OmniBSI are trademarks of OmniVision Technologies, Inc. All other trademarks are the property of their respective owners.