



Chipsmall Limited consists of a professional team with an average of over 10 year of expertise in the distribution of electronic components. Based in Hongkong, we have already established firm and mutual-benefit business relationships with customers from,Europe,America and south Asia,supplying obsolete and hard-to-find components to meet their specific needs.

With the principle of “Quality Parts,Customers Priority,Honest Operation,and Considerate Service”,our business mainly focus on the distribution of electronic components. Line cards we deal with include Microchip,ALPS,ROHM,Xilinx,Pulse,ON,Everlight and Freescale. Main products comprise IC,Modules,Potentiometer,IC Socket,Relay,Connector.Our parts cover such applications as commercial,industrial, and automotives areas.

We are looking forward to setting up business relationship with you and hope to provide you with the best service and solution. Let us make a better world for our industry!



Contact us

Tel: +86-755-8981 8866 Fax: +86-755-8427 6832

Email & Skype: info@chipsmall.com Web: www.chipsmall.com

Address: A1208, Overseas Decoration Building, #122 Zhenhua RD., Futian, Shenzhen, China



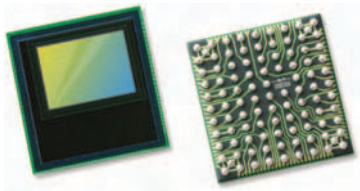

OV10626 HD HDR product brief



Day (Non-HDR)



Day (HDR)

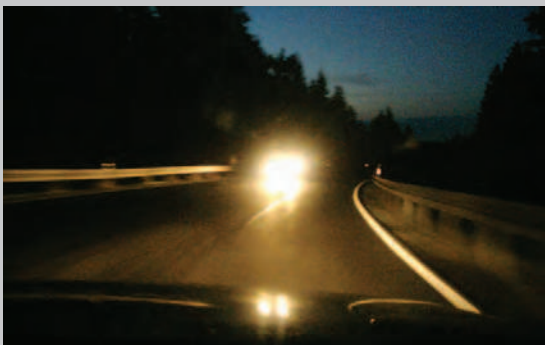

Night (Non-HDR)



Night (HDR)

Redefined Imaging Performance for Rear and Surround View Automotive Vision Systems



available in
a lead-free
package

The OV10626 is a single-chip, high-performance camera solution for rear and surround view automotive vision systems. The AutoVision sensor leverages advanced imaging concepts to deliver exceptional high dynamic range (HDR) while maintaining excellent low-light sensitivity.

The OV10626 supports 1/3.7-inch NTSC analog (648x488 resolution) and 1/3.2-inch WVGA digital (752x548 resolution) outputs. The sensor's color HDR of up to 120 dB and low-light sensitivity of 16 V/lux-sec ensures that clear, high-quality images are captured, even in extremely challenging lighting conditions.

The OV10626 also features a dual overlay function. This feature may be used for reference frames and guiding systems for backup and parking assist systems.

The compact OV10626 is packaged in OmniVision's proprietary AutoVision chip-scale package (a-CSP™), which is the industry's most efficient package available. The OV10626 will be qualified to AEC-Q100 Grade-2 Specifications (-40°C to +105°C).

Find out more at www.ovt.com.



Applications

- Automotive
 - 360° surround view
 - automotive machine vision
 - lane departure warning
 - traffic sign recognition
 - automatic high beam control
 - object detection
- pedestrian detection
- rear view camera
- blind spot detection
- mirror replacement
- occupant sensor
- night vision

Product Features

- support for image size: WVGA, VGA, QVGA and any cropped size
- high dynamic range
- high sensitivity
- safety features
- low power consumption
- image sensor processor functions:
 - automatic exposure/gain control
 - automatic white balance control
 - lens correction
 - defective pixel cancellation
 - HDR combination and tone mapping
 - automatic black level correction
- supported output formats: YUV, RAW, CCIR656
- horizontal and vertical sub-sampling
- serial camera control bus (SCCB) for register programming
- SPI master for overlay and loading settings
- external frame synchronization capability
- 50/60 Hz flicker cancellation
- parallel 16-bit DVP output
- NTSC with overlay and analog output
- embedded temperature sensor
- one time programmable (OTP) memory

OV10626

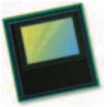

Ordering Information

- OV10626-N02V-PE**
(color, lead-free, 102-pin a-CSP™, rev 1D, 50°C packed in tray with protective film)

Product Specifications

- active array size:** 752 x 548
- power supply:**
 - core: 1.425 - 1.575V
 - analog: 3.14 - 3.47V
 - I/O: 1.7 - 3.47V
- power requirements:**
 - active: 410 mW typical @ 3.3V AVDD, 1.5V DVDD, and 1.8V DOVDD
 - standby: 260 μW typical @ 3.3V AVDD, 1.5V DVDD, and 1.8V DOVDD
- temperature range:**
 - operating: -40°C to +105°C sensor ambient temperature and -40°C to +125°C junction temperature (operating sensor junction temperatures above +60°C may result in degraded image quality)
- output interfaces:**
 - 16-bit parallel DVP, analog NTSC (single end and differential)
- output formats:** up to 20-bit combined RAW, separated 8-/10-bit RAW, 8-/10-bit YUV422
- lens size:**
 - VGA and NTSC: 1/3.7"
 - WVGA: 1/3.2"
- lens chief ray angle:** 9°
- input clock frequency:** 6 - 27 MHz
- maximum image transfer rate:** 60 fps full resolution
- sensitivity:** 16 V/lux-sec
- scan mode:** progressive
- shutter:** rolling shutter
- pixel size:** 6 μm x 6 μm
- dark current:** 44 mV/sec @ HCG, 14 mV/sec @ LCG
- image area:** 4608 μm x 3384 μm
- package dimensions:** 7310 μm x 7810 μm

Functional Block Diagram

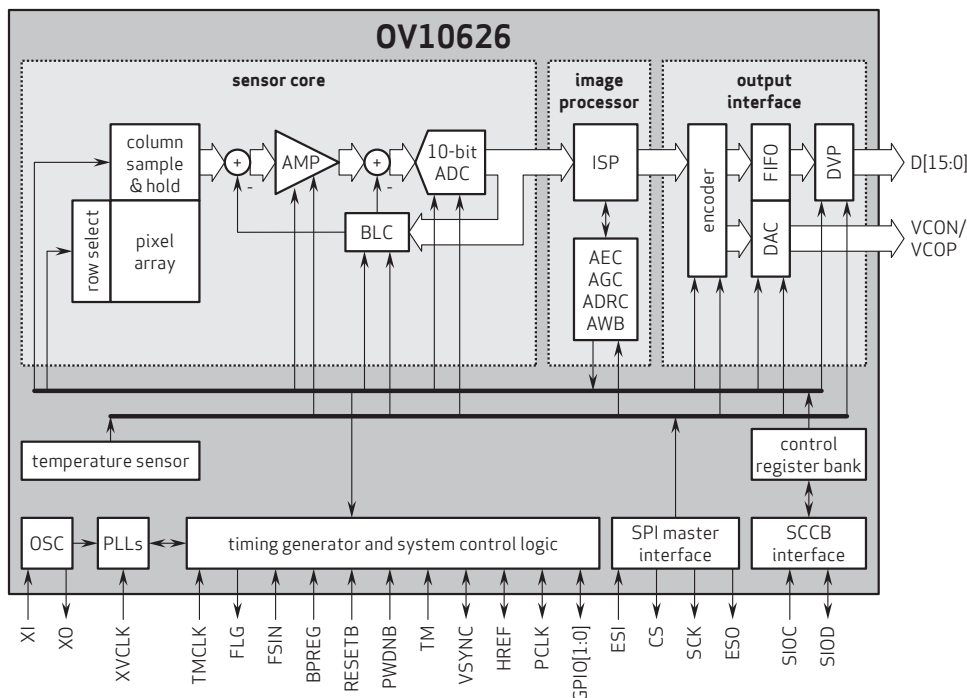

4275 Burton Drive
Santa Clara, CA 95054
USA

Tel: + 1 408 567 3000
Fax: + 1 408 567 3001
www.ovt.com

OmniVision reserves the right to make changes to their products or to discontinue any product or service without further notice. OmniVision and the OmniVision logo are registered trademarks of OmniVision Technologies, Inc. OmniBSI is a trademark of OmniVision Technologies, Inc. All other trademarks are the property of their respective owners.



OmniVision