



Chipsmall Limited consists of a professional team with an average of over 10 year of expertise in the distribution of electronic components. Based in Hongkong, we have already established firm and mutual-benefit business relationships with customers from,Europe,America and south Asia,supplying obsolete and hard-to-find components to meet their specific needs.

With the principle of “Quality Parts,Customers Priority,Honest Operation,and Considerate Service”,our business mainly focus on the distribution of electronic components. Line cards we deal with include Microchip,ALPS,ROHM,Xilinx,Pulse,ON,Everlight and Freescale. Main products comprise IC,Modules,Potentiometer,IC Socket,Relay,Connector.Our parts cover such applications as commercial,industrial, and automotives areas.

We are looking forward to setting up business relationship with you and hope to provide you with the best service and solution. Let us make a better world for our industry!



## Contact us

Tel: +86-755-8981 8866 Fax: +86-755-8427 6832

Email & Skype: info@chipsmall.com Web: www.chipsmall.com

Address: A1208, Overseas Decoration Building, #122 Zhenhua RD., Futian, Shenzhen, China



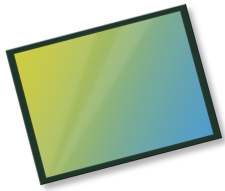

# OV13860 13MP product brief



## Industry's Best 13-Megapixel Image Sensor with Large 1.3-Micron Pixels and Stacked Die Technology for Flagship Smartphones



available in a lead-free package

The PureCel-S™ OV13860 is a unique 13-megapixel sensor with large 1.3-micron pixels – 35 percent larger than those of traditional 13-megapixel sensors. Despite its 1/2.6-inch sensor size, the OV13860 uses a high chief ray angle (CRA) to enable a camera module z-height of 5.5 mm, suitable for today's slim smartphones.

The OV13860 is the first of OmniVision's family of PureCel™ backside-illuminated image sensors to leverage the company's stacked die technology, which separates the imaging array from the image sensor processing pipeline into a stacked die structure. This allows for additional functionality to be implemented on the sensor while providing for much smaller die sizes compared to non-stacked sensors, thus enabling smaller module sizes for larger optical format sensors.

Among the OV13860's advanced features is autofocus contrast calculation at an extremely fast 120 frames per second (fps) while imaging at full-resolution to enable a fast autofocus camera system.

When paired with a high-speed actuator, the OV13860 can provide instant autofocus by delivering contrast statistics at up to four times faster than traditional single frame-based contrast calculations. The OV13860 also supports alternate row, dual-exposure high dynamic range (HDR) timing mode for delivering HDR video in challenging lighting scenes.

The OV13860's large 1.3-micron pixel enables dramatically improved high and low light performance as a result of higher sensitivity, signal-to-noise ratio, and full-well capacity when compared to products of similar or higher resolution with 1.12  $\mu\text{m}$  pixels. The OV13860 can capture full-resolution 13-megapixel still images at 30 fps or record ultra-high resolution 4K2K video at 30 fps, 1080p full HD at 60 fps, or 720p HD at 120 fps. Each video output format includes additional pixels to support electronic image stabilization (EIS).

Find out more at [www.ovt.com](http://www.ovt.com).



OmniVision.

## Applications

- Smartphones
- Tablets
- PC Multimedia

## Product Features

- 1.3  $\mu\text{m}$  x 1.3  $\mu\text{m}$  pixel
- optical size of 1/2.6"
- 13MP at 30 fps
- automatic black level calibration (ABLC)
- programmable controls for frame rate, mirror and flip, cropping, and windowing
- supports output formats: 16/14/12/10-bit HDR RAW or 10-bit RAW RGB
- supports horizontal and vertical subsampling
- supports 2x2 binning, re-sampling filter
- standard serial SCCB interface
- built-in temperature sensor
- up to 4-lane MIPI TX interface with speed up to 1.5 Gbps/lane
- 20kbits (or 2560 bytes) of OTP memory - 11kbits (or 1375 bytes) reserved for customer use
- alternate row HDR
- support for high speed auto focus at 120 Hz
- two on-chip phase lock loops (PLLs)
- programmable I/O drive capability
- image quality control: defect pixel correction (DPC), denoise, lens shading correction
- suitable for 9.5 x 9.5 x 5.5 mm module size

# OV13860



## Ordering Information

- OV13860-G05A-Z**  
(color, chip probing, 150  $\mu\text{m}$  backgrinding, reconstructed wafer with good die)

## Product Specifications

- active array size:** 4224 x 3120
- lens size:** 1/2.6"
- lens chief ray angle:** 33.4° non-linear
- input clock frequency:** 6 - 27 MHz
- maximum image transfer rate:**
  - 4224x3120: 30 fps
  - 2112x1560: 60 fps
- scan mode:** progressive
- pixel size:** 1.3  $\mu\text{m}$  x 1.3  $\mu\text{m}$
- image area:** 5554.1  $\mu\text{m}$  x 4113.4  $\mu\text{m}$
- die dimensions:**
  - COB: 6244.2  $\mu\text{m}$  x 4795.2  $\mu\text{m}$
  - RW: 6294.2  $\mu\text{m}$  x 4845.2  $\mu\text{m}$
- power supply:**
  - core: 1.2V
  - analog: 2.8V
  - I/O: 1.8V
- power requirements:**
  - active: TBD
  - standby: TBD
  - XSHUTDOWN: TBD
- temperature range:**
  - operating: -30°C to +85°C junction temperature
  - stable image: 0°C to +60°C junction temperature
- output formats:** 10-bit RGB RAW, 16/14/12/10-bit HDR RAW

## Functional Block Diagram

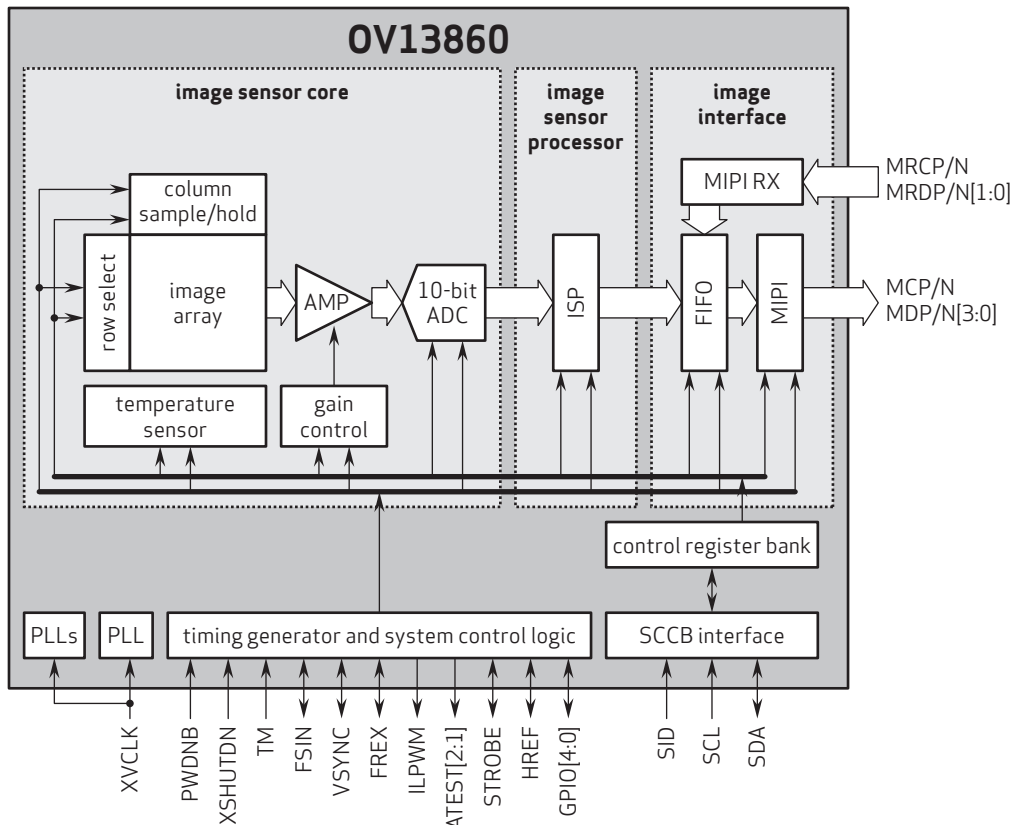

4275 Burton Drive  
Santa Clara, CA 95054  
USA

Tel: +1 408 567 3000  
Fax: +1 408 567 3001  
www.ovt.com

OmniVision reserves the right to make changes to their products or to discontinue any product or service without further notice. OmniVision and the OmniVision logo are registered trademarks of OmniVision Technologies, Inc. PureCel and PureCel-S are trademarks of OmniVision Technologies, Inc. All other trademarks are the property of their respective owners.



OmniVision