



Chipsmall Limited consists of a professional team with an average of over 10 year of expertise in the distribution of electronic components. Based in Hongkong, we have already established firm and mutual-benefit business relationships with customers from,Europe,America and south Asia,supplying obsolete and hard-to-find components to meet their specific needs.

With the principle of "Quality Parts,Customers Priority,Honest Operation,and Considerate Service",our business mainly focus on the distribution of electronic components. Line cards we deal with include Microchip,ALPS,ROHM,Xilinx,Pulse,ON,Everlight and Freescale. Main products comprise IC,Modules,Potentiometer,IC Socket,Relay,Connector.Our parts cover such applications as commercial,industrial, and automotives areas.

We are looking forward to setting up business relationship with you and hope to provide you with the best service and solution. Let us make a better world for our industry!



Contact us

Tel: +86-755-8981 8866 Fax: +86-755-8427 6832

Email & Skype: info@chipsmall.com Web: www.chipsmall.com

Address: A1208, Overseas Decoration Building, #122 Zhenhua RD., Futian, Shenzhen, China



Optimal XIV Star Series

White, Multi-LED

OV14Zxx-y

- 500+ Lumen High Output Series
- Multiple 1-watt chips in recessed cavity with an optical grade 8mm diameter lens - other lens designs possible
- Exceptional thermal resistance (1.8°C/W junction to heatsink)
- Solder Pads Au Plated

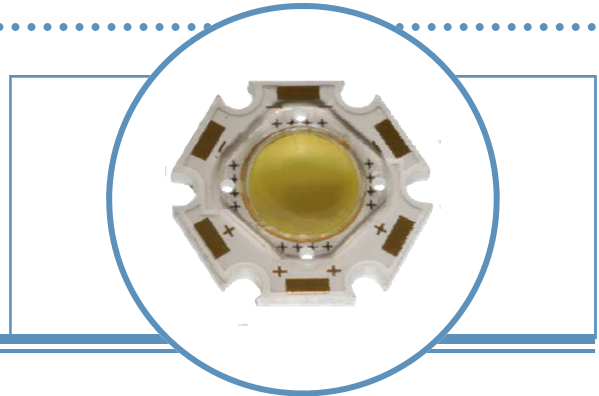

The OV14Zx-y Star Series is designed with high flux output and exceptional thermal resistance by recessing the multiple die into the metal core PCBoard.

Applications

- Portable Flashlights
- Security / Garden Lighting
- Indoor /Outdoor Commercial Lighting
- Architectural Lighting
- Light Guides
- MR16 Lighting

Part Number	Current Drive (mA)	Viewing Angle	Emitted CCT(K)	Total Luminous Flux (lm)		Forward Voltage (V _F)
	Max	Typ.	Typ.	Min.	Typ.	Typ.
OV14ZW-1	700	120°	6500	300	350	10.0
OV14ZW-2	1050			450	510	
OV14ZW-3	1400			550	650	
OV14ZWD-1	700		5400	300	350	
OV14ZWD-2	1050			450	510	
OV14ZWD-3	1400			550	650	
OV14ZWW-1	700		3300	250	300	
OV14ZWW-2	1050			400	450	
OV14ZWW-3	1400			500	550	

Color	Minimum CCT (°K)	Maximum CCT (°K)
Cool White	6000	8000
Daylight White	4750	6000
Warm White	2760	3800



RoHS



DO NOT LOOK DIRECTLY AT LED WITH UNSHIELDED EYES OR DAMAGE TO RETINA MAY OCCUR.

OPTEK reserves the right to make changes at any time in order to improve design and to supply the best product possible.

Absolute Maximum Ratings

Parameter	Symbol	Part Number	MAX	Unit
Average Forward Current ^{[2][3]}	I _F	OV14Zxx-1	700	mA
		OV14Zxx-2	1050	
		OV14Zxx-3	1400	
Power Dissipation	P _D	OV14Zxx-1	7.9	W
		OV14Zxx-2	12	
		OV14Zxx-3	16	
Operating Temperature Range ^[3]	T _{opr}	-40°C to 85°C		
Storage Temperature Range	T _{sto}	-40°C to 100°C		
LED Junction Temperature ²	T _j	125°C		
Terminal Soldering Condition	T _{sol}	260°C / 5 seconds		

Notes:

1. Pulse width 1 ms maximum. Duty cycle 1/16
2. Design of Heat Dissipation should be considered.
3. The allowable operating current at different ambient temperatures - see Fig. 1
4. Thermal Resistance junction to Heatsink (T_{jhs}) is <2° C/W

Outline Drawings

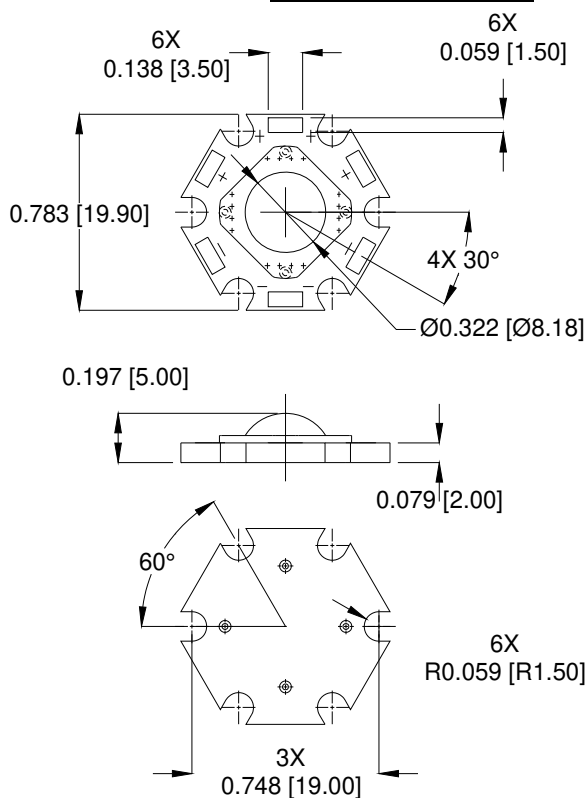

Internal Electrical Diagram

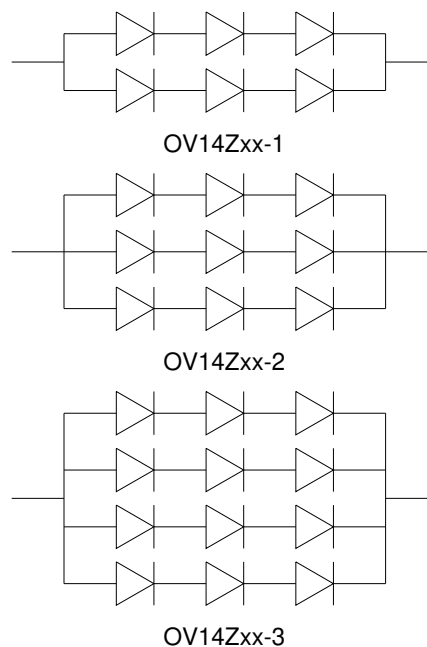

OPTEK's Optimal XIV Series Solid State Lighting products package the highest quality LED chips. Typically, the lumen output of these can be as high as 70% after 50,000 hours of operation. This prediction is based on specific test results and on tests on similar materials, and relies on strict observation of the design limits and ratings included in this data sheet.

OPTEK reserves the right to make changes at any time in order to improve design and to supply the best product possible.

CIE Chromaticity Diagram

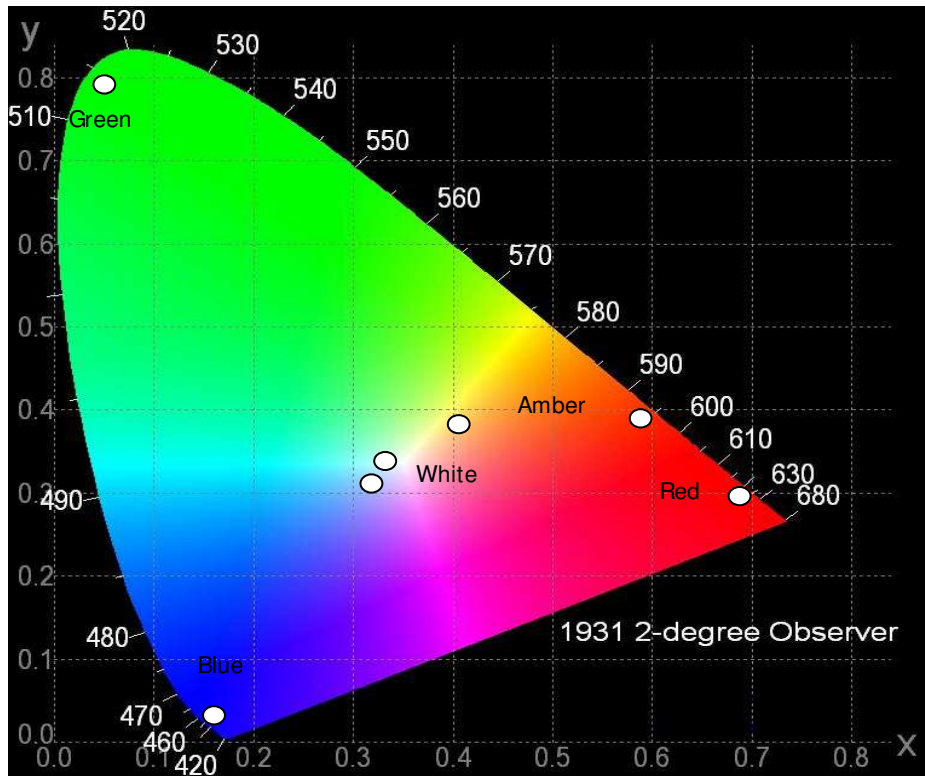

Spatial Intensity Distribution

Normalized Spectral Intensity vs Angular Displacement

120.1 degrees

OPTEK reserves the right to make changes at any time in order to improve design and to supply the best product possible.

Chromaticity Coordinates Specifications for Bin Grading

Warm White	Rank	A01				A02				A03				A04			
	X	0.4705	0.4866	0.4767	0.4614	0.4614	0.4767	0.4671	0.4525	0.4525	0.4671	0.4577	0.4436	0.4436	0.4577	0.4490	0.4356
	Y	0.4508	0.4541	0.4366	0.4333	0.4333	0.4366	0.4196	0.4162	0.4162	0.4196	0.4029	0.3991	0.3991	0.4029	0.3875	0.3837
	CCT	2760 (TYP)															
	Rank	B01				B02				B03				B04			
	X	0.4538	0.4705	0.4614	0.4456	0.4456	0.4614	0.4525	0.4376	0.4376	0.4525	0.4436	0.4294	0.4294	0.4436	0.4356	0.4221
	Y	0.4460	0.4508	0.4333	0.4287	0.4287	0.4333	0.4162	0.4116	0.4116	0.4162	0.3991	0.3943	0.3943	0.3991	0.3837	0.3790
	CCT	2950 (TYP)															
	Rank	C01				C02				C03				C04			
	X	0.4385	0.4538	0.4456	0.4312	0.4312	0.4456	0.4376	0.4240	0.4240	0.4376	0.4294	0.4165	0.4165	0.4294	0.4221	0.4100
	Y	0.4404	0.4460	0.4287	0.4234	0.4234	0.4287	0.4116	0.4065	0.4065	0.4116	0.3943	0.3890	0.3890	0.3943	0.3790	0.3738
	CCT	3150 (TYP)															
	Rank	D01				D02				D03				D04			
	X	0.4209	0.4385	0.4312	0.4148	0.4148	0.4312	0.4240	0.4086	0.4086	0.4240	0.4165	0.4021	0.4021	0.4165	0.4100	0.3966
Y	0.4326	0.4404	0.4234	0.4161	0.4161	0.4234	0.4065	0.3995	0.3995	0.4065	0.3890	0.3822	0.3822	0.3890	0.3738	0.3673	
CCT	3375 (TYP)																
Rank	E01				E02				E03				E04				
X	0.4023	0.4209	0.4148	0.3963	0.3963	0.4148	0.4086	0.3934	0.3934	0.4086	0.4021	0.3871	0.3871	0.4021	0.3966	0.3826	
Y	0.4228	0.4326	0.4161	0.4035	0.4035	0.4161	0.3995	0.3909	0.3909	0.3995	0.3822	0.3739	0.3739	0.3822	0.3672	0.3595	
CCT	3650 (TYP)																
Rank	F01				F02				F03				F04				
X	0.3860	0.4023	0.3963	0.3811	0.3811	0.3963	0.3924	0.3783	0.3783	0.3924	0.3871	0.3741	0.3741	0.3871	0.3826	0.3706	
Y	0.4130	0.4228	0.4035	0.3937	0.3937	0.4035	0.3909	0.3825	0.3825	0.3909	0.3739	0.3658	0.3658	0.3739	0.3595	0.3520	
CCT	3950 (TYP)																
Rank	G01				G02				G03				G04				
X	0.3673	0.3860	0.3811	0.3642	0.3642	0.3811	0.3783	0.3622	0.3622	0.3783	0.3741	0.3594	0.3594	0.3741	0.3706	0.3571	
Y	0.4003	0.4130	0.3937	0.3829	0.3829	0.3937	0.3825	0.3716	0.3716	0.3825	0.3658	0.3557	0.3557	0.3658	0.3520	0.3426	
CCT	4300 (TYP)																
Rank	H01				H02				H03				H04				
X	0.3481	0.3673	0.3642	0.3469	0.3469	0.3642	0.3622	0.3458	0.3458	0.3622	0.3594	0.3444	0.3444	0.3594	0.3571	0.3434	
Y	0.3856	0.4003	0.3829	0.3717	0.3717	0.3829	0.3716	0.3592	0.3592	0.3716	0.3557	0.3442	0.3442	0.3557	0.3426	0.3320	
CCT	4750 (TYP)																
Rank	I01				I02				I03				I04				
X	0.3286	0.3481	0.3469	0.3288	0.3288	0.3469	0.3458	0.3290	0.3290	0.3458	0.3444	0.3292	0.3292	0.3444	0.3434	0.3294	
Y	0.3690	0.3856	0.3717	0.3569	0.3569	0.3717	0.3592	0.3451	0.3451	0.3592	0.3442	0.3313	0.3313	0.3442	0.3320	0.3202	
CCT	5300 (TYP)																
Rank	J01				J02				J03				J04				
X	0.3136	0.3286	0.3288	0.3148	0.3148	0.3288	0.3290	0.3160	0.3160	0.3290	0.3292	0.3175	0.3175	0.3292	0.3291	0.3186	
Y	0.3550	0.3690	0.3569	0.3444	0.3444	0.3569	0.3451	0.3332	0.3332	0.3451	0.3313	0.3204	0.3204	0.3313	0.3202	0.3102	
CCT	6000 (TYP)																
Rank	J05				K01				K02				K03				
X	0.3186	0.3294	0.3295	0.3196	0.3011	0.3136	0.3148	0.3031	0.3031	0.3148	0.3160	0.3052	0.3052	0.3160	0.3175	0.3076	
Y	0.3102	0.3202	0.3105	0.3013	0.3422	0.3550	0.3444	0.3327	0.3327	0.3444	0.3332	0.3224	0.3224	0.3332	0.3204	0.3108	
CCT	6000 (TYP)								6700 (TYP)								
Rank	K04				L01				L02								
X	0.3076	0.3175	0.3196	0.3111	0.2742	0.3031	0.3076	0.2830	0.2830	0.3076	0.3112	0.2900					
Y	0.3108	0.3204	0.3013	0.2932	0.3007	0.3327	0.3108	0.2838	0.2838	0.3108	0.2932	0.2703					
CCT	6700 (TYP)								8000 (TYP)								

OPTeK reserves the right to make changes at any time in order to improve design and to supply the best product possible.

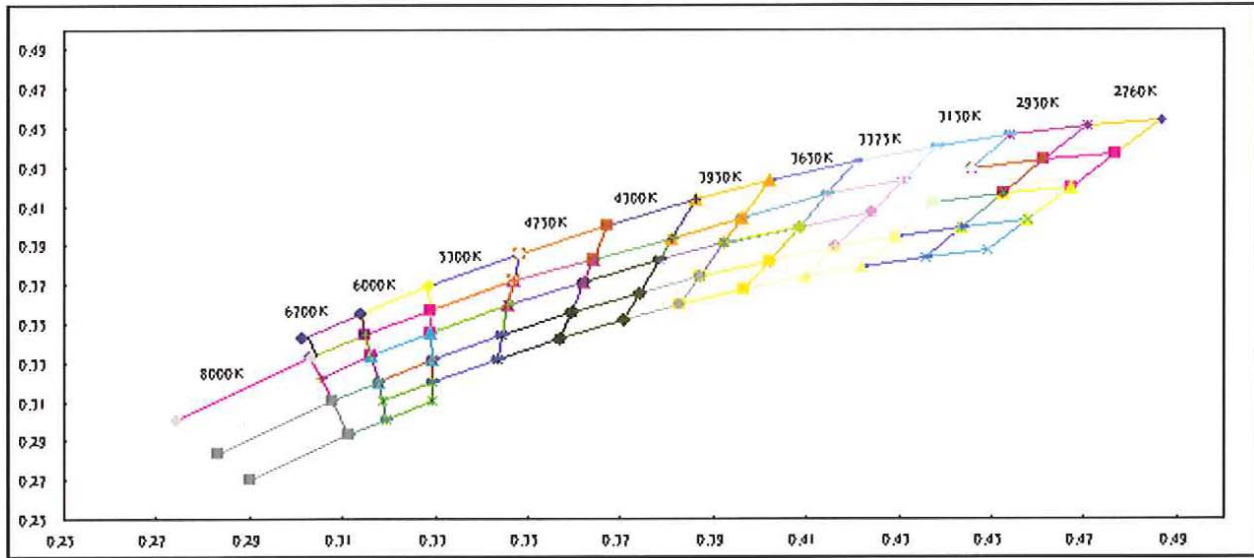

Typical Electrical / Optical Characteristics Curves

(25°C Ambient Temperature Unless Otherwise Noted)

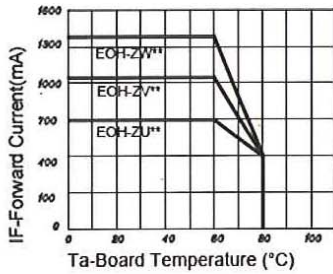

Fig.1 Allowable Forward Current vs. Ambient Temperature

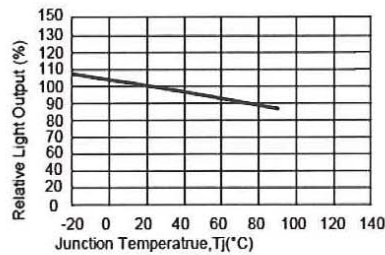

Fig.2 Luminous Intensity vs. Forward Current

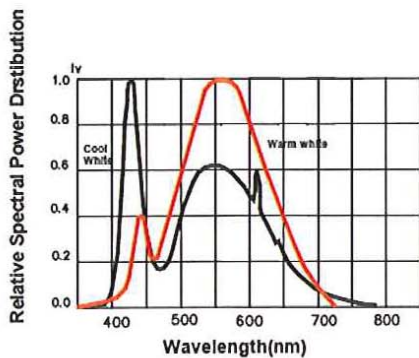

Fig.3 Relative Luminous Intensity vs. Wavelength

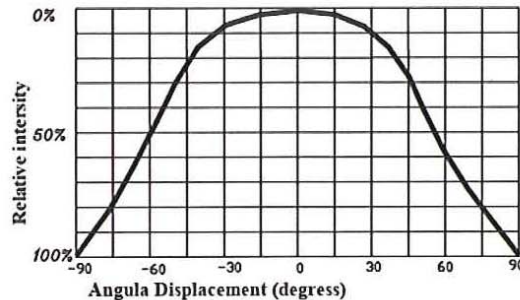

Fig.4 Typical Representative Spatial Radiation Pattern of Single LED

Note: 1. The data shown above are typical curves. Every LED component may have some variations of characteristics.
2. The maximum driving current should be limited in proper value (see Fig. 1 above) and use of an adequate heat sink

OPTEK reserves the right to make changes at any time in order to improve design and to supply the best product possible.

Reliability Criteria & Results

EOI's High Power LED s are checked by reliability test based on MIL standards.

1. Test Conditions, Accept Criteria & Results:

Classification	Test Item	Reference Standard	Test Conditions	Duration	Units Tested	Number of Damaged
Operation Test	Operating Life Test		$T_A = 25^{\circ}\text{C} \pm 5^{\circ}\text{C}$	1000 Hrs	22	0/22
			OV14Zxx-1 $I_F = 700\text{mA}$			
			OV14Zxx-2 $I_F = 1050\text{mA}$			
			OV14Zxx-3 $I_F = 1400\text{mA}$			
Environment Test	High Temperature Storage	JEITA ED-4701 200 201	$T_A = 100^{\circ}\text{C} \pm 5^{\circ}\text{C}$	1000 Hrs	22	0/22
	Low Temperature	JEITA ED-4701 200 201	$T_A = -40^{\circ}\text{C} \pm 5^{\circ}\text{C}$	1000 Hrs	22	0/22
	Thermal Shock	JEITA ED-4701 200 201	$-40^{\circ}\text{C} \pm 5^{\circ}\text{C} \leftrightarrow +85^{\circ}\text{C} \pm 5^{\circ}\text{C}$ 30min dwell/5 min transfer	50Cycles	22	0/22

2. Reliability Criteria:

Item	Symbol	Test Conditions	Criteria for Judgement	
			Min	Max
Forward Voltage	V_F	OV14Zxx-1 $I_F = 700\text{ mA}$	----	Initial Data x 1.1
		OV14Zxx-2 $I_F = 1050\text{ mA}$		
		OV14Zxx-3 $I_F = 1400\text{ mA}$		
Luminous Flux	1m	OV14Zxx-1 $I_F = 700\text{ mA}$	Initial Data x 0.5	----
		OV14Zxx-2 $I_F = 1050\text{ mA}$		
		OV14Zxx-3 $I_F = 1400\text{ mA}$		

Shipment Packaging and Packing:

1. Packaging quantity : 10 stars / tube
2. Packing box contains 10 tubes

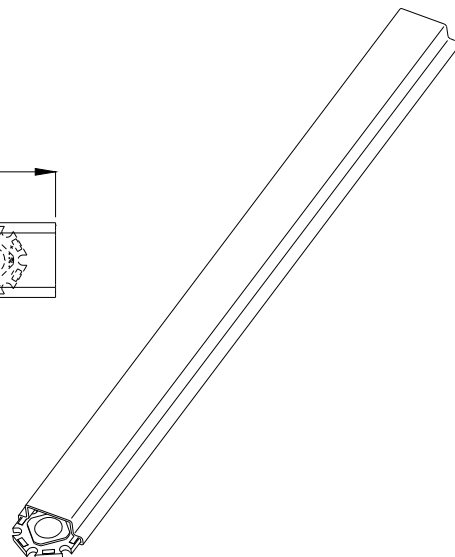
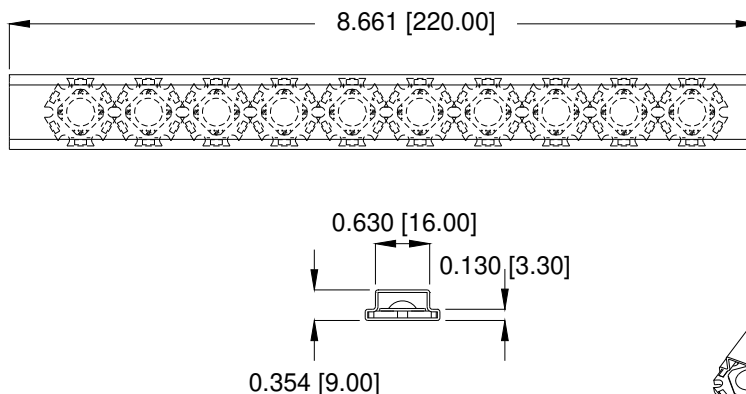

OPTEK reserves the right to make changes at any time in order to improve design and to supply the best product possible.