



Chipsmall Limited consists of a professional team with an average of over 10 year of expertise in the distribution of electronic components. Based in Hongkong, we have already established firm and mutual-benefit business relationships with customers from,Europe,America and south Asia,supplying obsolete and hard-to-find components to meet their specific needs.

With the principle of "Quality Parts,Customers Priority,Honest Operation,and Considerate Service",our business mainly focus on the distribution of electronic components. Line cards we deal with include Microchip,ALPS,ROHM,Xilinx,Pulse,ON,Everlight and Freescale. Main products comprise IC,Modules,Potentiometer,IC Socket,Relay,Connector.Our parts cover such applications as commercial,industrial, and automotives areas.

We are looking forward to setting up business relationship with you and hope to provide you with the best service and solution. Let us make a better world for our industry!



Contact us

Tel: +86-755-8981 8866 Fax: +86-755-8427 6832

Email & Skype: info@chipsmall.com Web: www.chipsmall.com

Address: A1208, Overseas Decoration Building, #122 Zhenhua RD., Futian, Shenzhen, China



White High-Intensity LED Lamp (3 mm, 45° Viewing Angle)

OVLAW4CB6

- High luminous intensity
- Blue LED + yellow phosphor
- Through-hole type
- Water clear lens
- Available on tape and reel

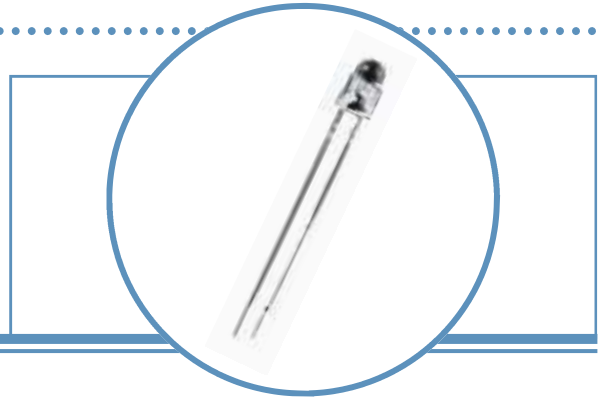

The **OVLAW4CB6** is a round 3 mm white high-intensity through-hole lamp with a 45° viewing angle. It is designed for wide-angle uniform light output.

Applications

- Indicators for medical, industrial, consumer and office equipment
- Indicators for white goods and home appliances
- Interior and exterior architectural and accent lighting
- Signs and digital information displays, video screen non-color and RGB presentation
- Automotive backlighting and indicators

Part Number	Material	Emitted Color	Intensity Typ. mcd	Lens Color
OVLAW4CB6	InGaN	White	1000	Water Clear

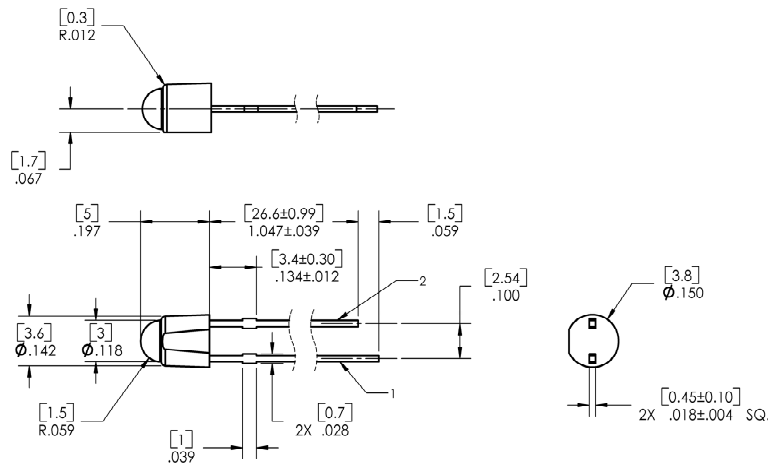

1 ANODE 2 CATHODE DIMENSIONS ARE IN INCHES AND [MILLIMETERS].



DO NOT LOOK DIRECTLY AT LED WITH UNSHIELDED EYES OR DAMAGE TO RETINA MAY OCCUR.

OPTEK reserves the right to make changes at any time in order to improve design and to supply the best product possible.

White High-Intensity LED Lamp

OVLAW4CB6



Absolute Maximum Ratings

T_A = 25° C unless otherwise noted

Storage Temperature Range	-40 ~ +100° C
Operating Temperature Range	-30 ~ +85° C
Reverse Voltage	5 V
DC Forward Current	30 mA
DC Forward Current Reduction ¹	-0.50 mA/° C
Power Dissipation	120 mW
Lead Soldering Temperature (5 seconds maximum)	260° C

Electrical Characteristics

T_A = 25° C unless otherwise noted

SYMBOL	PARAMETER	MIN	TYP	MAX	UNITS	CONDITIONS
I _V	Luminous Intensity ² (Axial Direction)	----	1000	----	mcd	I _F = 20 mA
V _{FL}	Forward Voltage	2.8	3.4	3.9	V	I _F = 20 mA
I _R	Reverse Current	----	----	10	μA	V _R = 5 V
x	Chromaticity	----	0.31	----	----	I _F = 20 mA
y		----	0.32	----	----	I _F = 20 mA

Notes:

- Under this condition: T_{OPR} = 40 ~ 85° C.
- Guaranteed value is 20% higher and/or lower than this value.

Standard Bins (I_F = 20 mA)

Lamps are sorted to luminous intensity (I_V) and chromaticity coordinates (x, y) bins shown. Orders for OVLAW4CB6 may be filled with any or all bins contained as below.

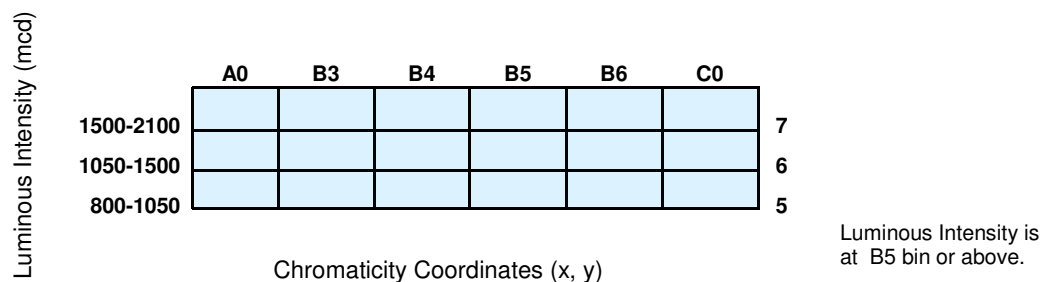

Rank		A0	B3	B4	B5	B6	C0
Chromaticity Coordinates	x	0.280-0.264	0.287-0.283	0.307-0.304	0.296-0.287	0.311-0.307	0.330-0.330
	y	0.248-0.267	0.295-0.305	0.315-0.330	0.276-0.295	0.294-0.315	0.318-0.360

Notes:

- All ranks will be included per delivery, rank ratio will be based on the chip distribution.
- To designate luminous intensity ranks, please contact OPTEK.
- Pb content <1000 PPM.

OPTEK reserves the right to make changes at any time in order to improve design and to supply the best product possible.

CIE Chromaticity Diagram

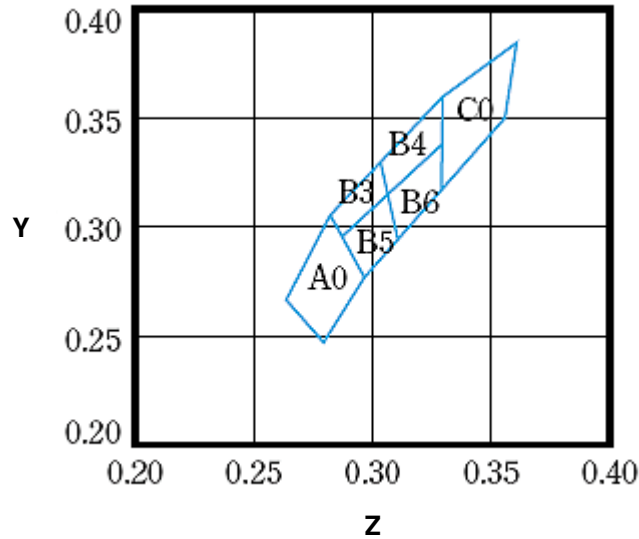

Beam Pattern

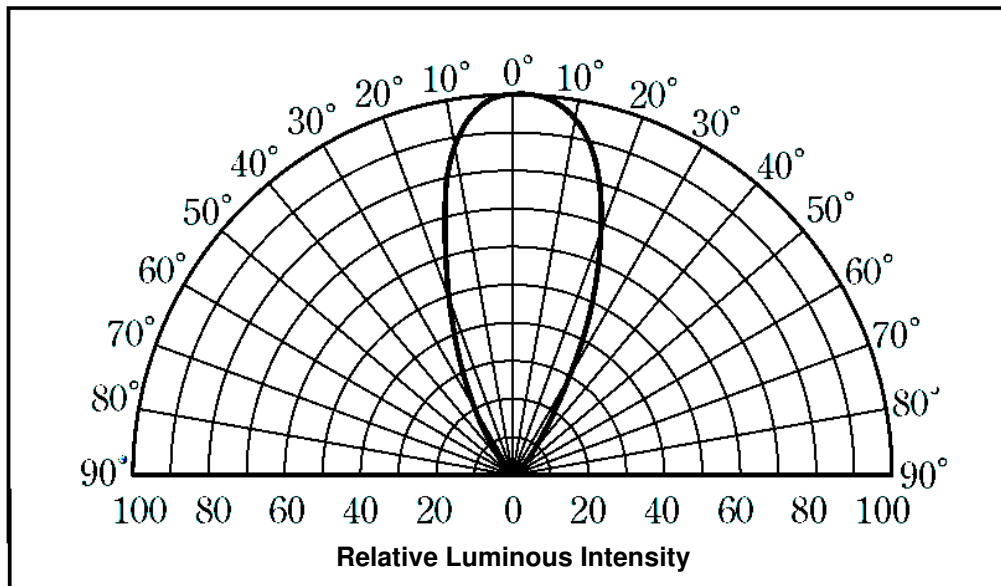

OPTEK reserves the right to make changes at any time in order to improve design and to supply the best product possible.

Typical Electro-Optical Characteristics Curves

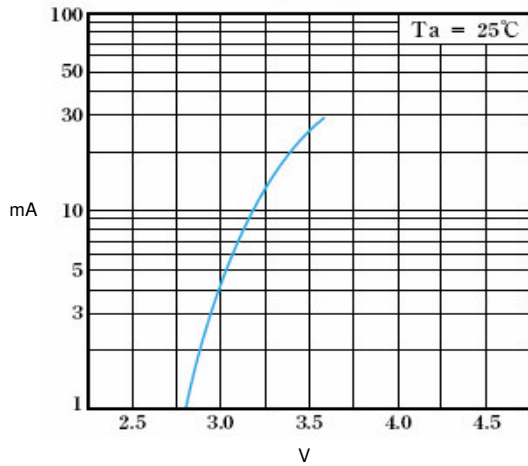

Forward Current vs Forward Voltage

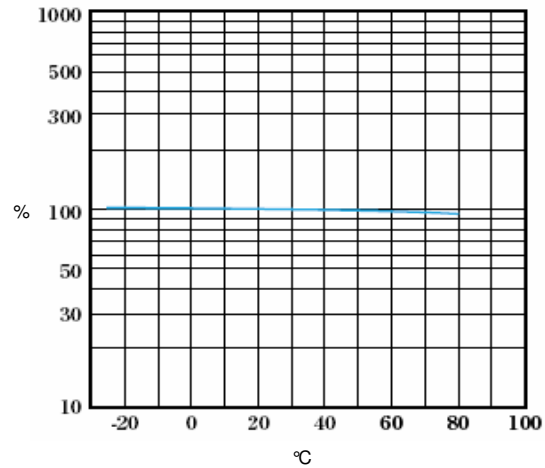

Relative Luminous Intensity vs Ambient Temperature

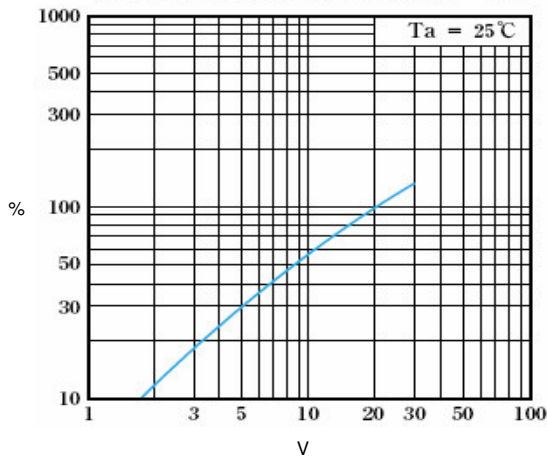

Relative Luminous Intensity vs Forward Current

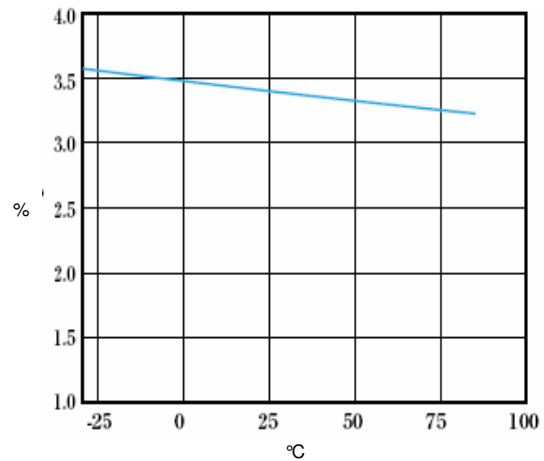

Forward Voltage vs Ambient Temperature

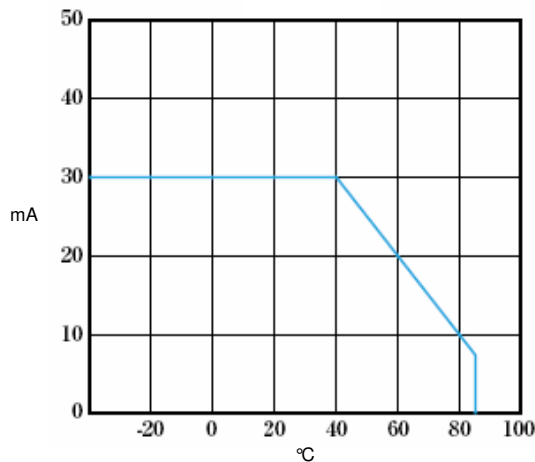

Forward Current vs Ambient Temperature

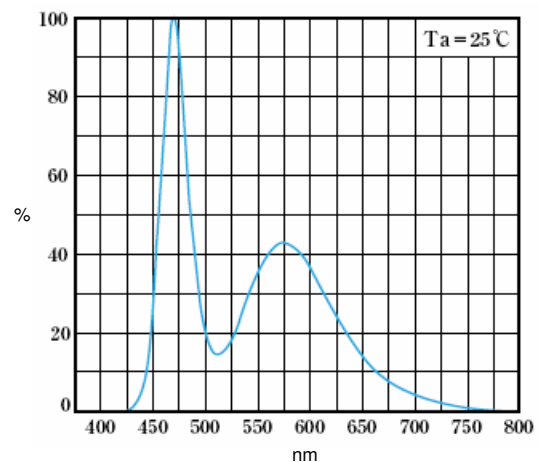

Relative Luminous Intensity vs Wavelength

OPTEK reserves the right to make changes at any time in order to improve design and to supply the best product possible.

White High-Intensity LED Lamp OVLAW4CB6

Packing Information: Available in bulk or reel

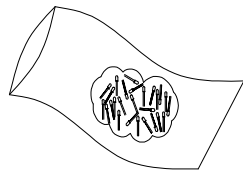

Bulk: 200 pcs/ESD protected bag

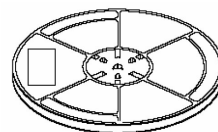

13-Inch Reel: 2000 pcs/reel

Carrier Tape Dimensions: Loaded quantity 2000 pieces per reel

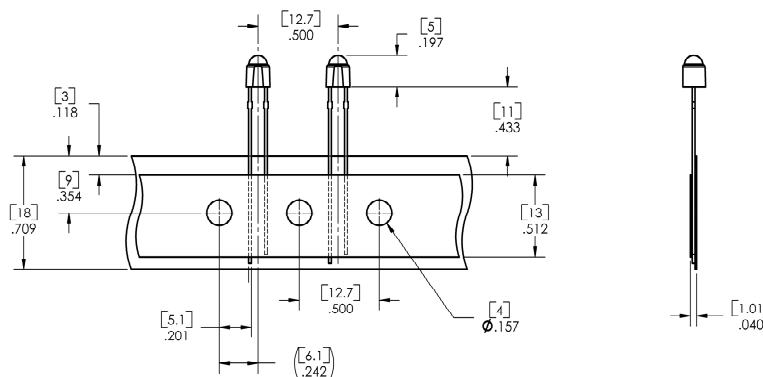

DIMENSIONS ARE IN INCHES AND (MILLIMETERS).

Moisture Resistant Packaging

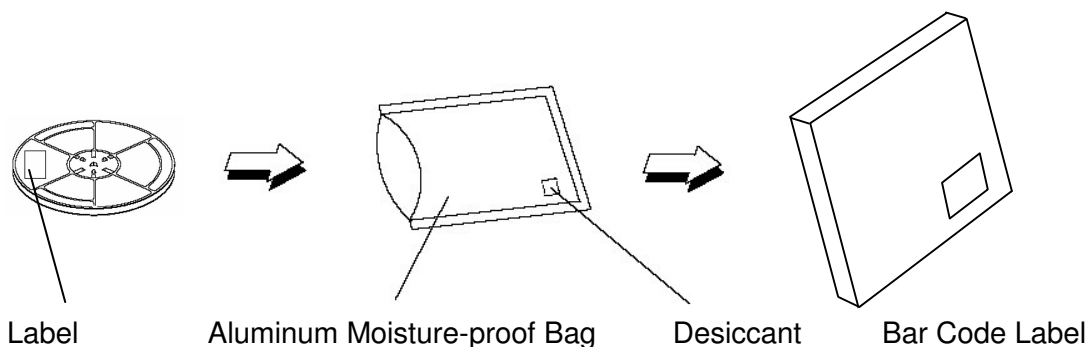

OPTEK reserves the right to make changes at any time in order to improve design and to supply the best product possible.