



Chipsmall Limited consists of a professional team with an average of over 10 year of expertise in the distribution of electronic components. Based in Hongkong, we have already established firm and mutual-benefit business relationships with customers from,Europe,America and south Asia,supplying obsolete and hard-to-find components to meet their specific needs.

With the principle of “Quality Parts,Customers Priority,Honest Operation,and Considerate Service”,our business mainly focus on the distribution of electronic components. Line cards we deal with include Microchip,ALPS,ROHM,Xilinx,Pulse,ON,Everlight and Freescale. Main products comprise IC,Modules,Potentiometer,IC Socket,Relay,Connector.Our parts cover such applications as commercial,industrial, and automotives areas.

We are looking forward to setting up business relationship with you and hope to provide you with the best service and solution. Let us make a better world for our industry!



## Contact us

Tel: +86-755-8981 8866 Fax: +86-755-8427 6832

Email & Skype: info@chipsmall.com Web: www.chipsmall.com

Address: A1208, Overseas Decoration Building, #122 Zhenhua RD., Futian, Shenzhen, China



# NICKEL CADMIUM BATTERIES: INDIVIDUAL DATA SHEET

## P-11AAH 1/3AA size (KR15/18) Type: H

Dimensions (with tube) (mm)

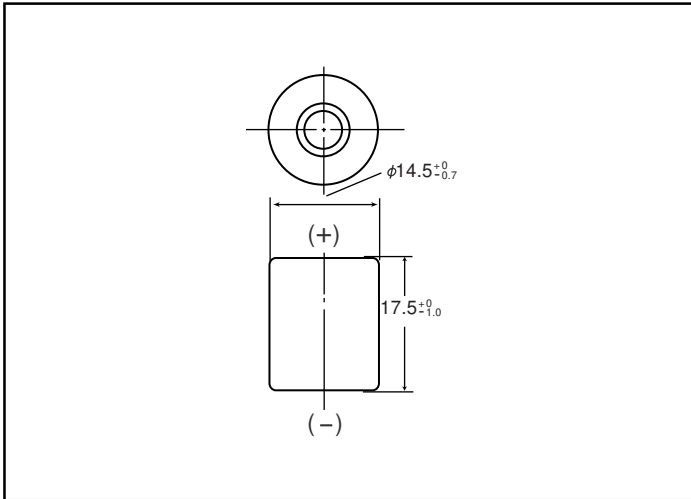

### Specifications

	mm	inch
Diameter	14.5 +0/-0.7	0.57 +0/-0.03
Height	17.5 +0/-1.0	0.69 +0/-0.04
Approximate Weight	Grams	Ounces
	6.5g	0.23

Nominal Voltage		1.2V	
Discharge Capacity*	Average**	120mAh	
	Rated (Min.)	110mAh	
Approx. Internal impedance at 1000Hz at charged state		80mΩ	
Charge	Standard	11mA (0.1It) x 16 hrs.	
	Trickle	Max Current	5.5mA (0.05It) x 30h and over
		Min Current	3.7mA (0.033It) x 45h and over
Ambient Temperature	Charge	°C	°F
		0°C to 50°C	32°F to 122°F
	Discharge	-20°C to 65°C	-4°F to 149°F
		Storage	< 2 years
	< 6 months		-20°C to 45°C -4°F to 113°F
	< 1 month		-20°C to 55°C -4°F to 131°F

\* 0.2It discharge capacity after charging at 0.1It for 16 hours.

\*\* For reference only.

Battery performance and cycle life are strongly affected by how they are used. In order to maximize battery safety, please consult Panasonic when determining charge / discharge specs, warning label contents and unit design.

**Note:** [It] was previously expressed as [C]. [It] is an IEC standard expression for the amount of charge or discharge current and is expressed as:

$$It(A) = Cn (Ah)/1h.$$

- [It] is the reference test current in amperes
- [Cn] is the rated capacity of the cell or battery in Ampere-hours.  
n = the time base [hours] for which the rated capacity is declared

### Typical Charge Characteristics

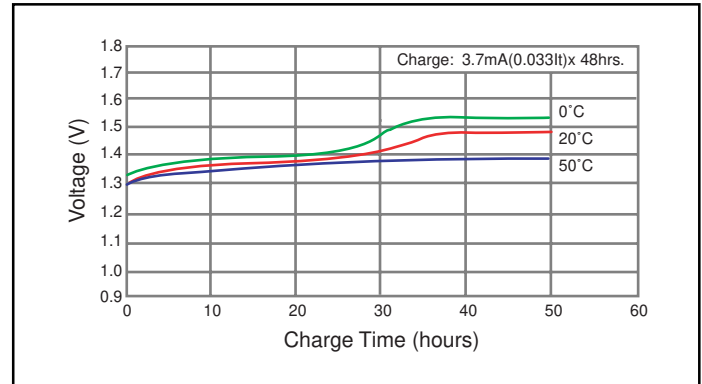

### Typical Discharge Characteristics

