



Chipsmall Limited consists of a professional team with an average of over 10 year of expertise in the distribution of electronic components. Based in Hongkong, we have already established firm and mutual-benefit business relationships with customers from,Europe,America and south Asia,supplying obsolete and hard-to-find components to meet their specific needs.

With the principle of “Quality Parts,Customers Priority,Honest Operation,and Considerate Service”,our business mainly focus on the distribution of electronic components. Line cards we deal with include Microchip,ALPS,ROHM,Xilinx,Pulse,ON,Everlight and Freescale. Main products comprise IC,Modules,Potentiometer,IC Socket,Relay,Connector.Our parts cover such applications as commercial,industrial, and automotives areas.

We are looking forward to setting up business relationship with you and hope to provide you with the best service and solution. Let us make a better world for our industry!



Contact us

Tel: +86-755-8981 8866 Fax: +86-755-8427 6832

Email & Skype: info@chipsmall.com Web: www.chipsmall.com

Address: A1208, Overseas Decoration Building, #122 Zhenhua RD., Futian, Shenzhen, China



THIS COPY IS PROVIDED ON A RESTRICTED BASIS AND IS NOT TO BE USED IN ANY WAY DETRIMENTAL TO THE INTERESTS OF PANDUIT CORP.

2

1

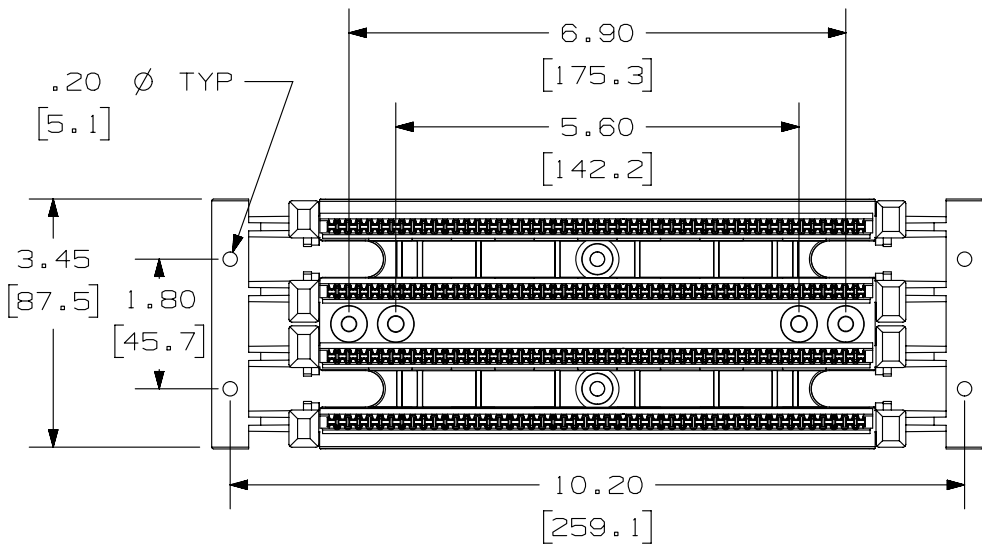

PANDUIT PART NO.	WEIGHT
P110BW100-X	.53 LB/EACH 240 g/EACH

- NOTE:
1. DIMENSIONS ARE NOMINAL UNLESS OTHERWISE SPECIFIED.
 2. TOOTH GEOMETRY IN WIRE SEPARATOR SIMPLIFIED FOR DRWG CLARITY.
 3. WIRE SEPARATOR MARKED ACCORDING TO 25-PAIR TIP COLOR SCHEME.
 4. DIMENSIONS IN [] ARE IN METRIC UNITS.

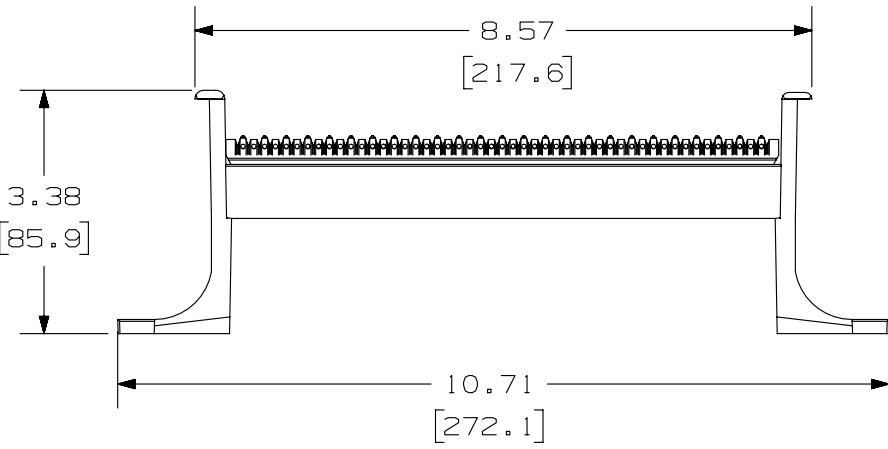
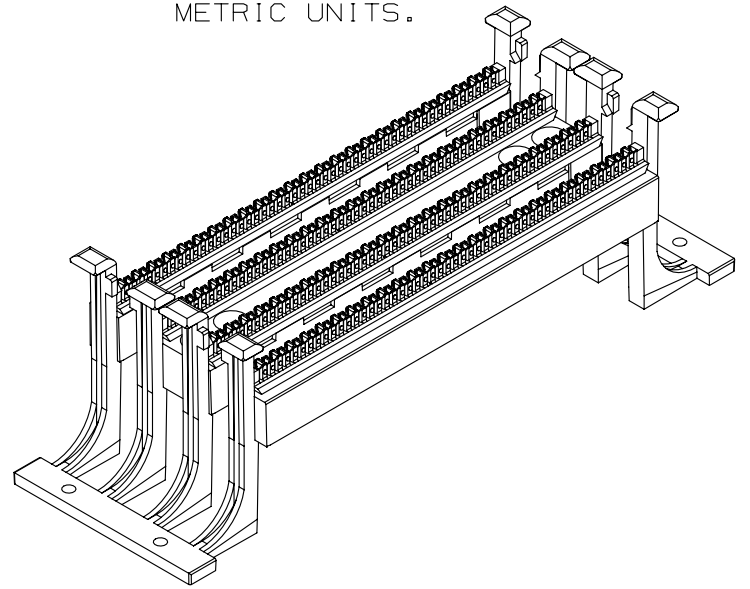

PART NUMBER		P110BW100-X	
TITLE			
110 PUNCHDOWN SYSTEM 100 PAIR BASE WITH LEGS			
CUSTOMER DRAWING			
ITEM REVISION NAME		M00142CH/00	
DATASET FILE NAME		M00142CH_DC36/00B	
UNLESS OTHERWISE SPECIFIED, DIMENSIONAL TOLERANCES ARE: IN [mm]		MATERIAL:	
.x ± .xxx ± .010 [.3]		POLYCARBONATE	
.xx ± .03 [.8]		DRAWING NUMBER:	
ANGLES ±		00142-36	
THIRD ANGLE PROJECTION		SHT 1 OF 1	
DRAWN BY	DATE	CHK	SCALE
JSP	11-22-99	CEF	NONE
REV	DATE	BY	CHK
1	5-27-14	MDJR	REFR
R	11-22-99	JSP	CEF

REV	DATE	BY	CHK	APR	DESCRIPTION	ECN
1	5-27-14	MDJR	REFR	MMR	A. UPDATED TITLE BLOCK.	00142-36
R	11-22-99	JSP	CEF	CEF	RELEASED TO PRODUCTION	00142-36

2

1

D10100DA/14